

HS - Höherführung

TECKENTRUP
DOOR SOLUTIONS

MONTAGEANLEITUNG - MANUEL DE MONTAGE

Achtung! Die HS-Federkonfigurationszeichnungen auf dieser Seite sind gültig für alle HS-Federkonfigurationszeichnungen, die in dieser Montageanleitung folgen.

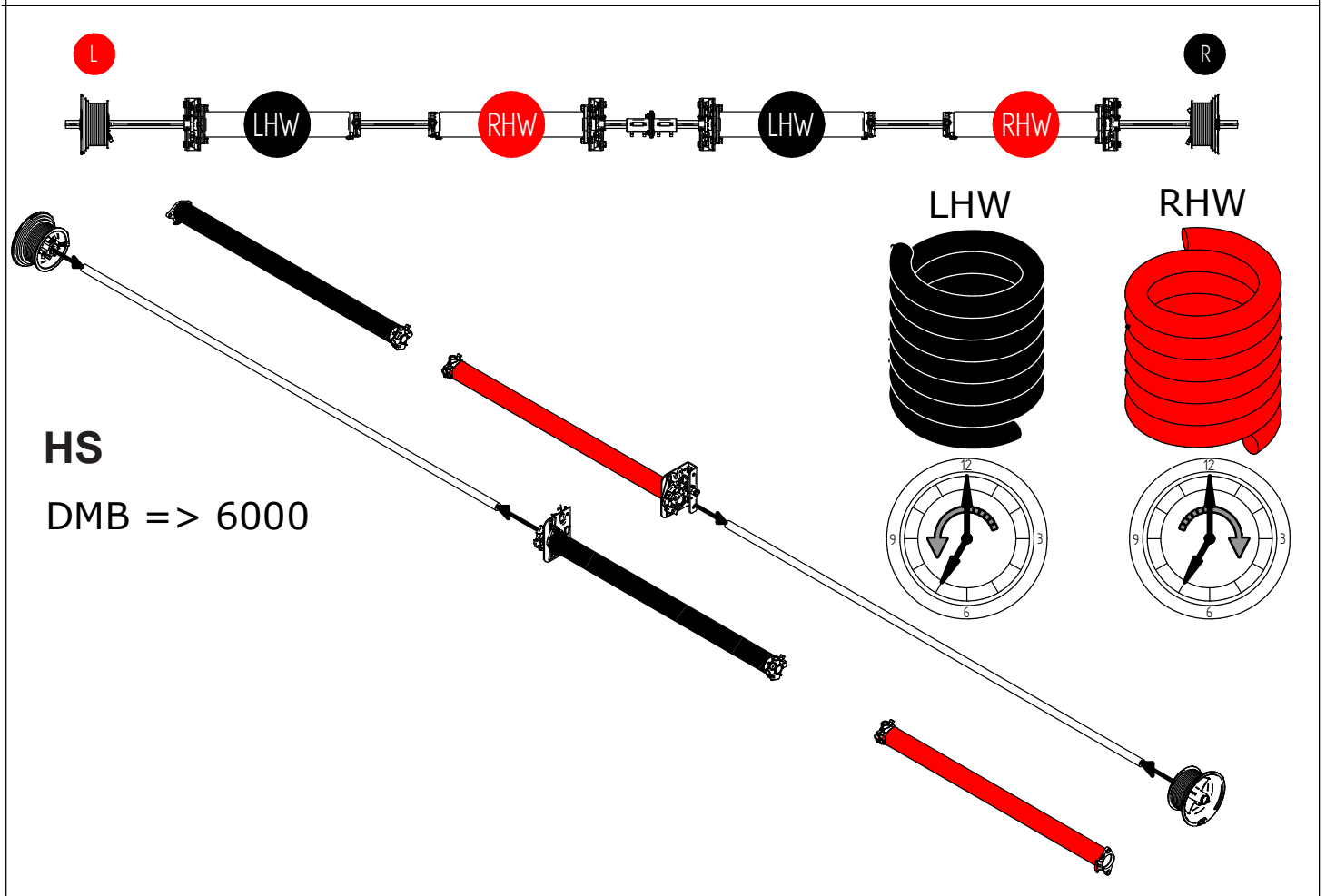
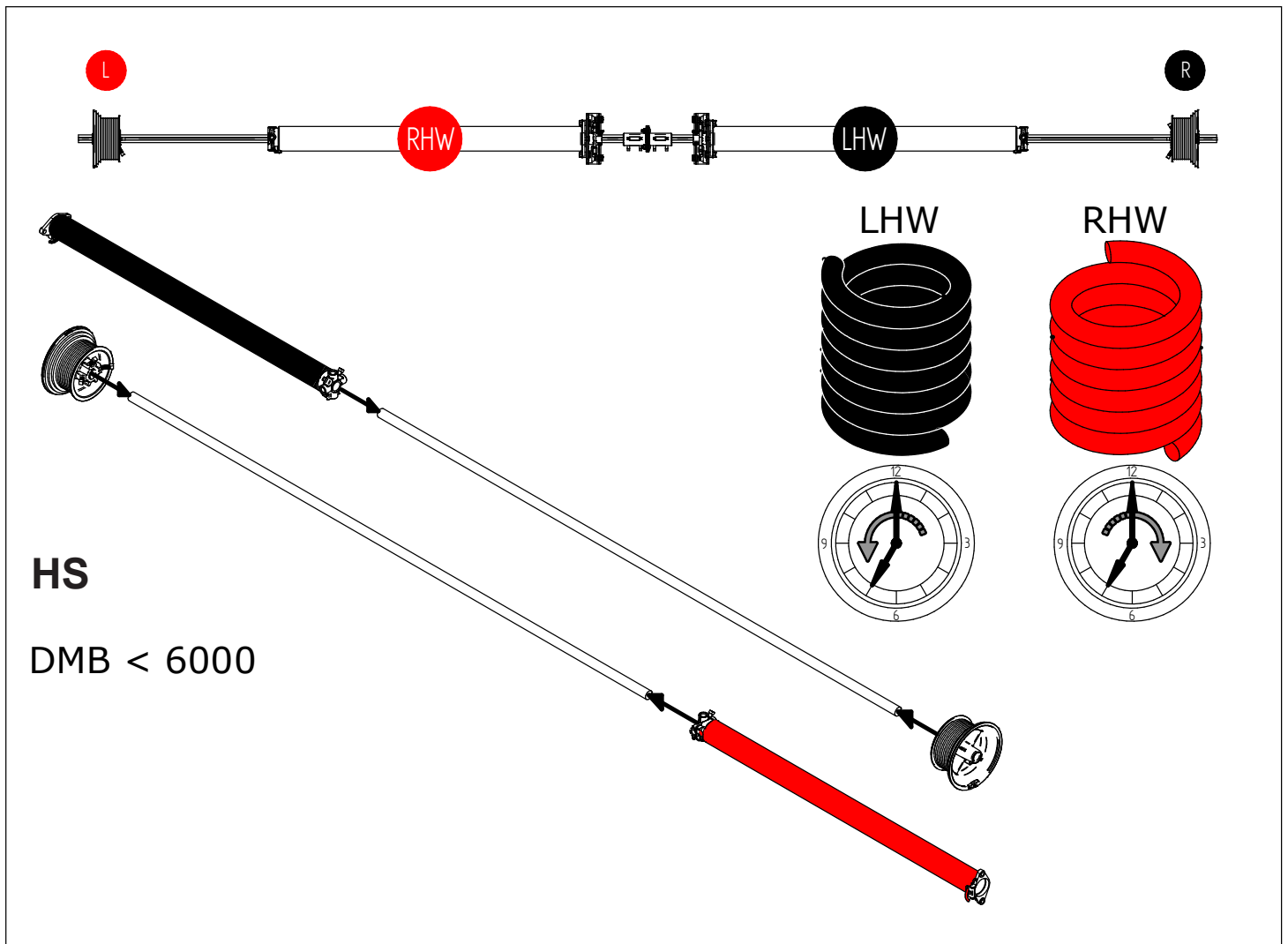

Achtung! Die HS-Federkonfigurationszeichnungen auf dieser Seite sind gültig für alle HS-Federkonfigurationszeichnungen, die in dieser Montageanleitung folgen.

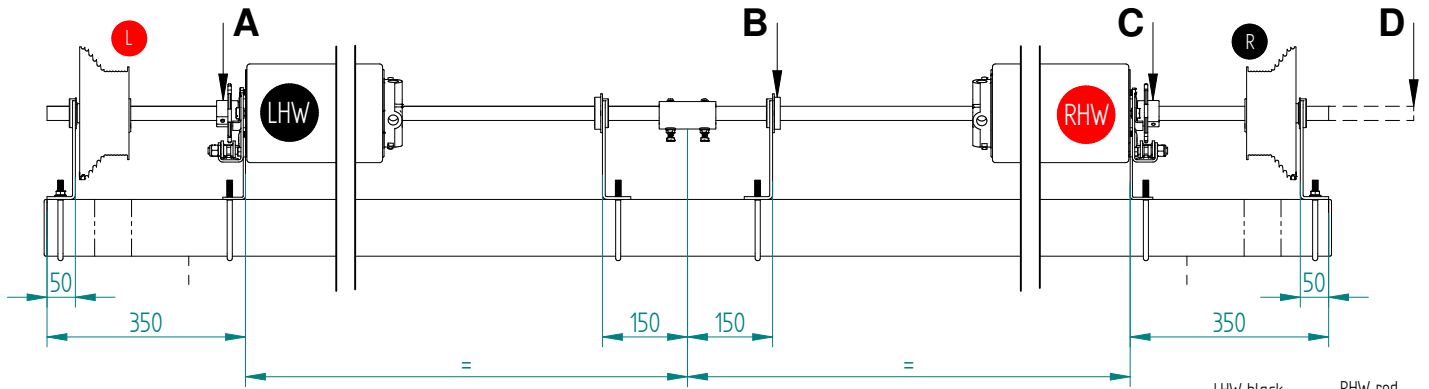

HSK Standard & Direct

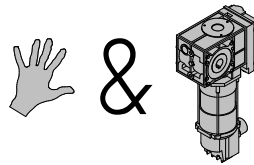

● = Black
● = Red

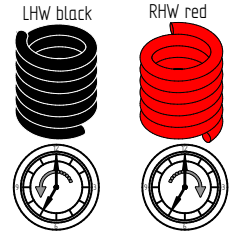

	A	B	C	D
NL	VBB LHW of Lagerplaat + lager	Als DMB > 4750mm	VBB RHW of Lagerplaat + lager	Motorbediend L of R
EN	SBD LHW or Bearing plate + bearing	When DLW > 4750mm	SBD RHW or Bearing plate + bearing	Motor operated L or R
DE	FBS LHW oder Lagerkonsole + lager	Wenn TLB > 4750mm	FBS RHW oder Lagerkonsole + lager	Antriebe L oder R
FR	Pare-chute ressort LHW ou palier + roulement	Si LDB > 4750mm	Pare-chute ressort RHW ou palier + roulement	Motorisée D ou G

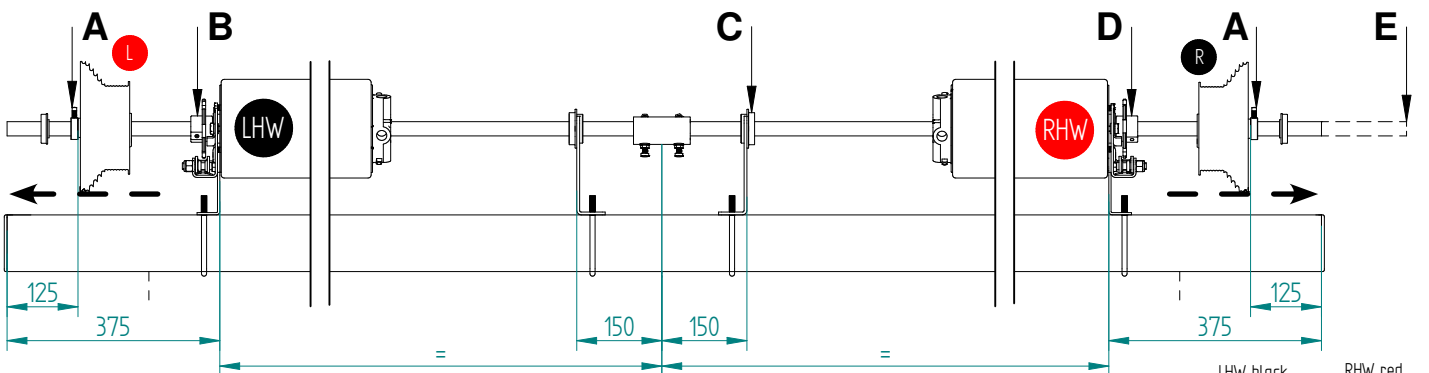

HSK oben montiert.

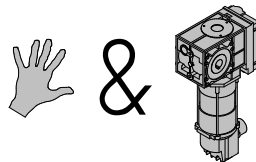

● = Black
● = Red

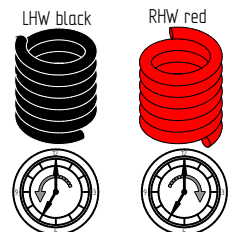

	A	B	C	D	E
NL	Stelling (HS) als HL > 1100mm	VBB LHW of Lagerplaat + lager + stelling	Als DMB > 4750mm	VBB RHW of Lagerplaat + lager + stelling	Motorbediend L of R
EN	Shaft collar (HL) when HL > 1100mm	SBD LHW or Bearing plate + bearing + shaft collar	When DLW > 4750mm	SBD RHW or Bearing plate + bearing + shaft collar	Motor operated L or R
DE	Stelling (HU) wenn HL > 1100mm	FBS LHW oder Lagerkonsole + lager + stelling	Wenn TLB > 4750mm	FBS RHW oder Lagerkonsole + lager + stelling	Antriebe L oder R
FR	Baque d'arrêt (LH) LH > 1100mm	Pare-chute ressort LHW ou palier + roulement + baque d'arrêt	LDB > 4750mm	Pare-chute ressort RHW ou palier + roulement + baque d'arrêt	Motorisée D ou G

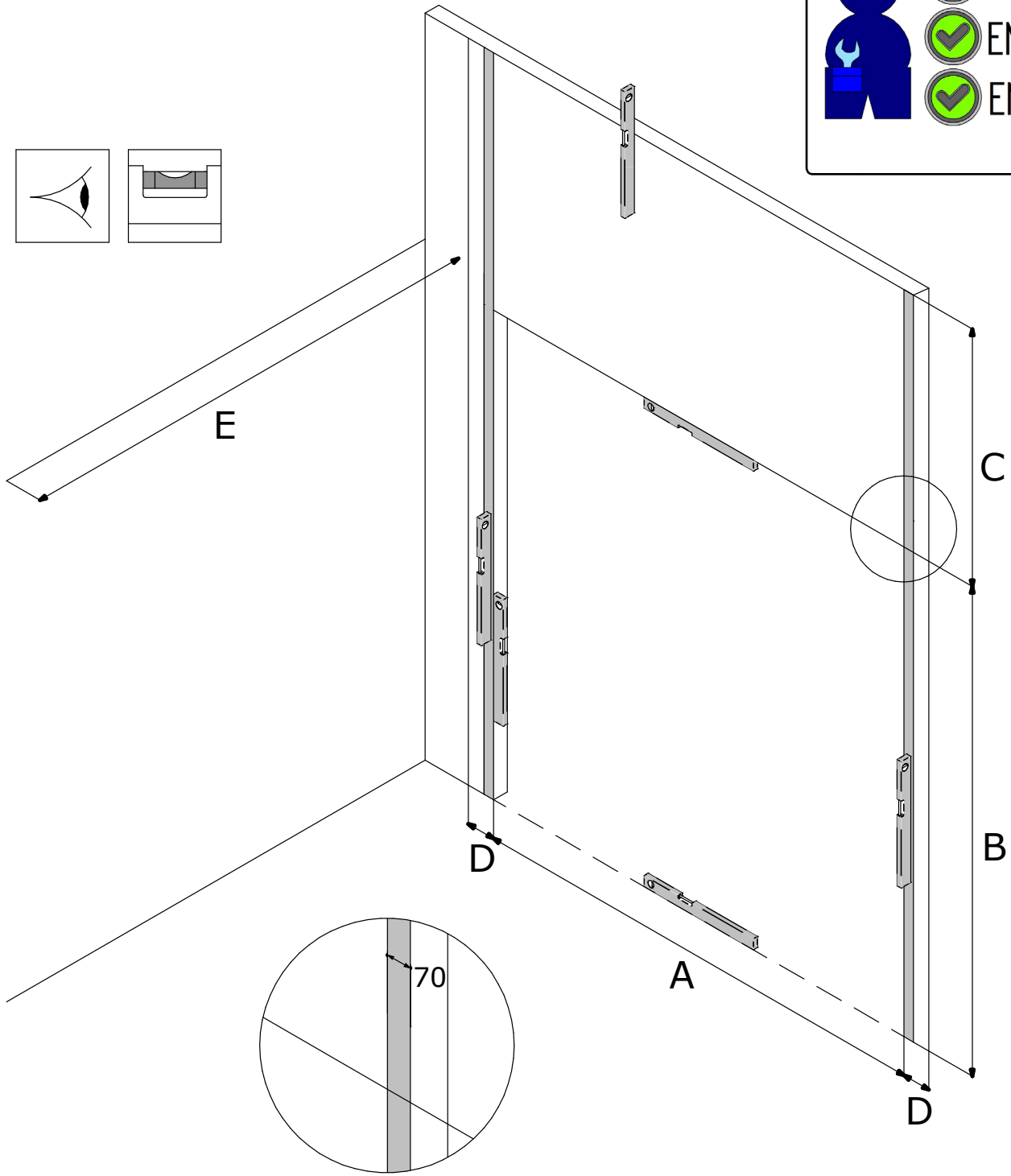
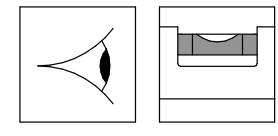
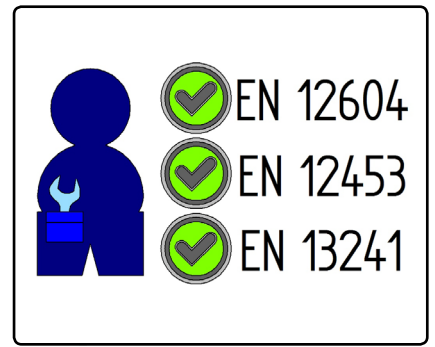

	A	B	C	D	E
	DLW	DLH	FHR	FSR	FMD
NL	Dagmaat breedte	Dagmaat hoogte	Vrije bovenruimte	Vrije zijruimte	Inbouwdiepte
EN	Day Light Width	Day Light Height	Free Head Room	Free Side Room	Free Mounting Depth
DE	Tageslichtbreite	Tageslichthöhe	Sturzfreiraum	Freie Seitenraum	Freie Einbautiefe
FR	Largeur de baie	Hauteur de baie	Linéau disponible	Ecoinçons Requis	Recul
RO	Lățime Gol	Înălțime Gol	Buiandrug Liber	Spațiul Liber Lateral	Spațiul Liber în Adâncime
HU	Szélesség	Magasság	Szabad szemöldök magasság	Szabad hely oldalt	Szabad beépítési mélység
SE	Dager bredd	Dager höjd	Minsta erforderligt höjdutrymme	Fritt sidoutrymme	Fritt monterings utrymme

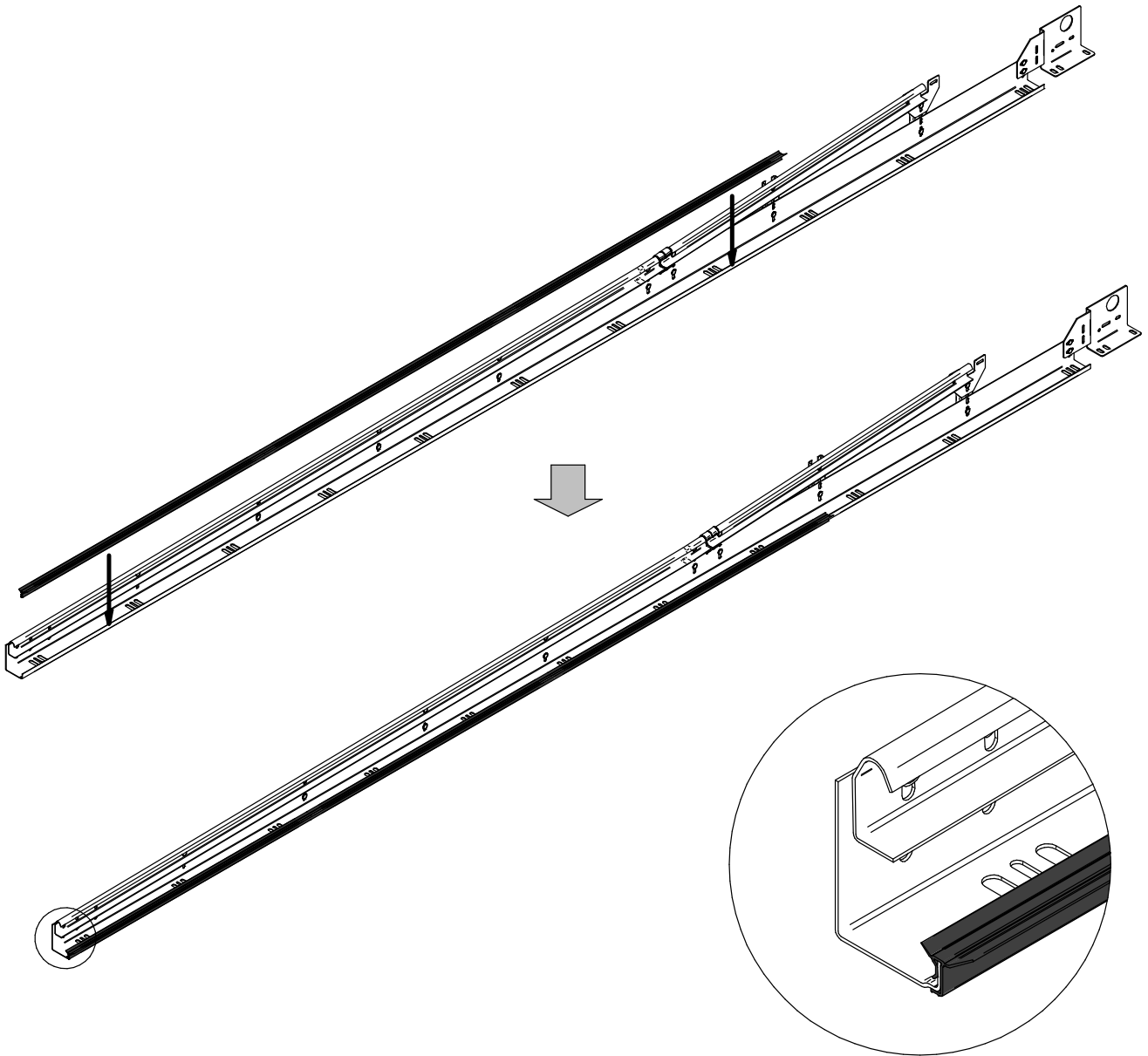
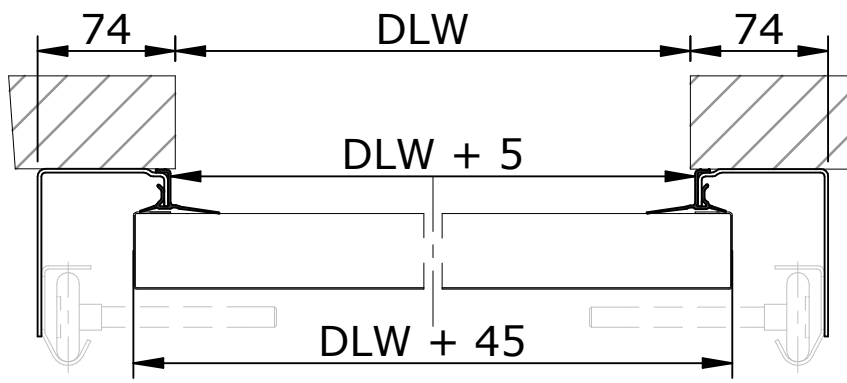

3199

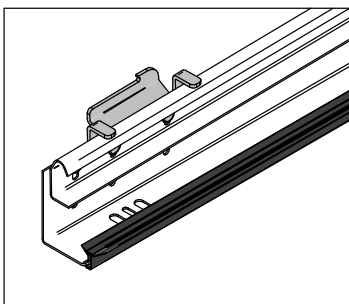

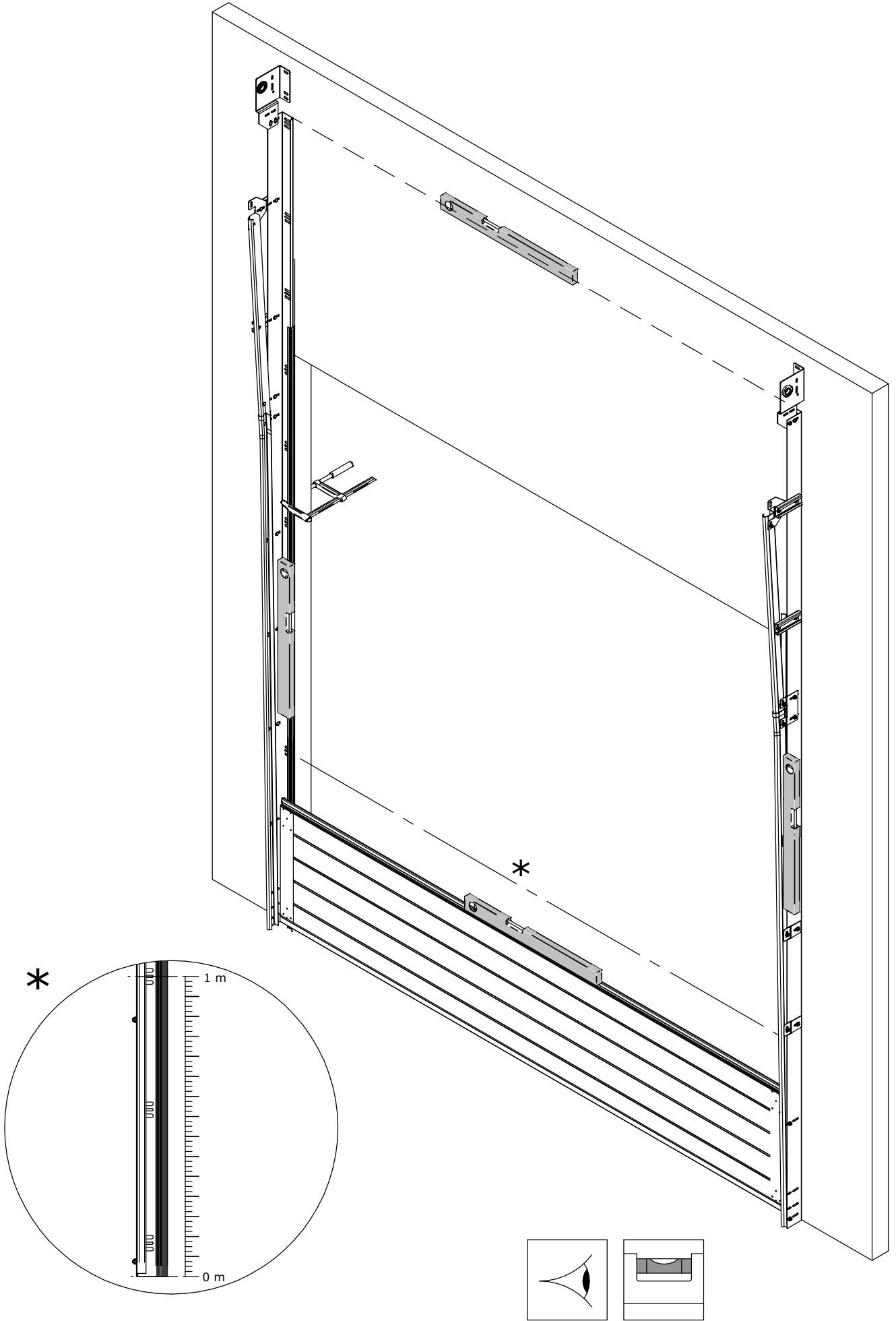

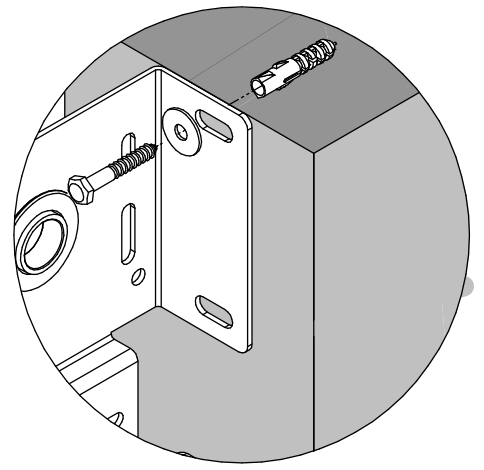
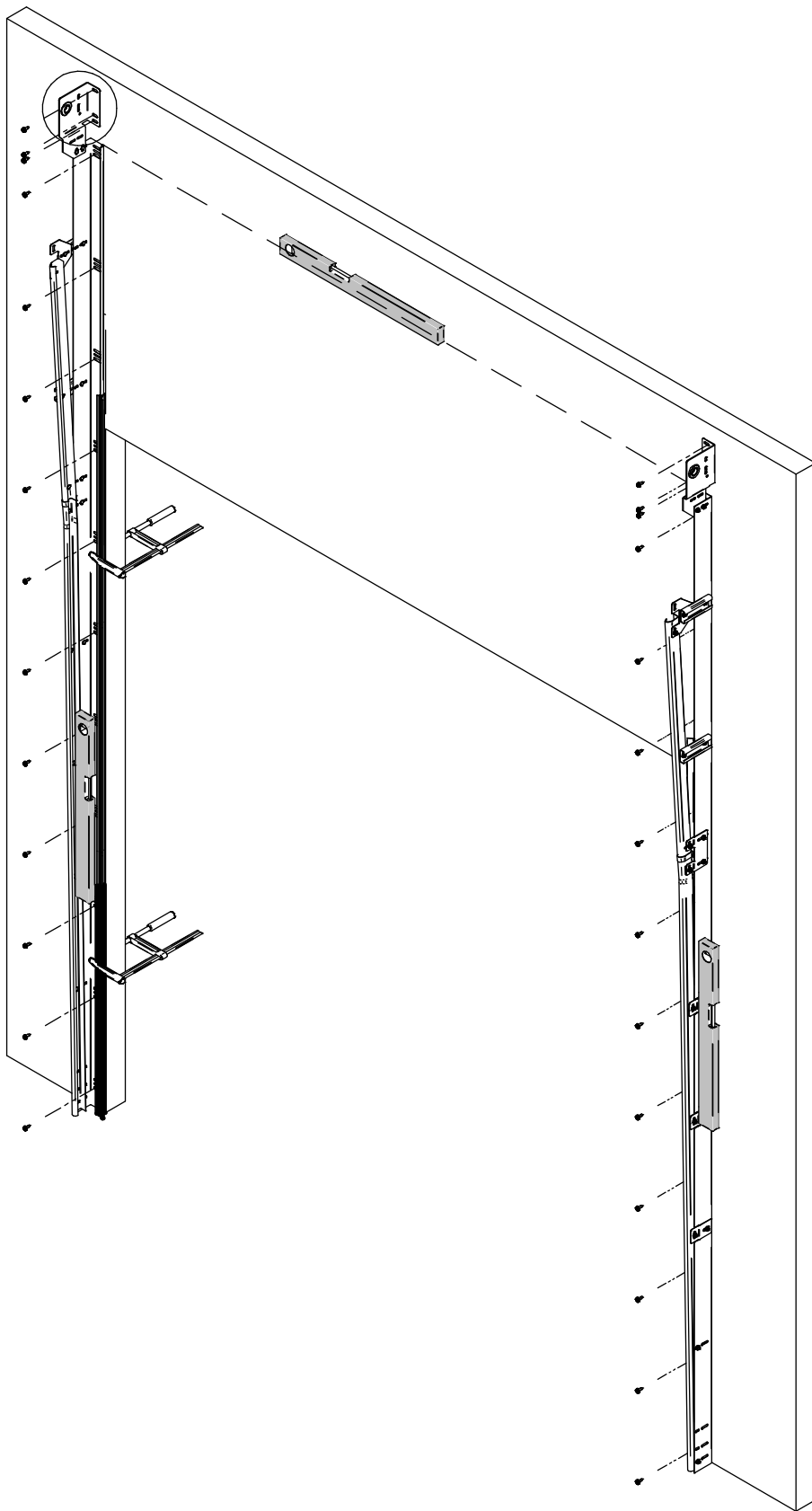

Φ10

0351

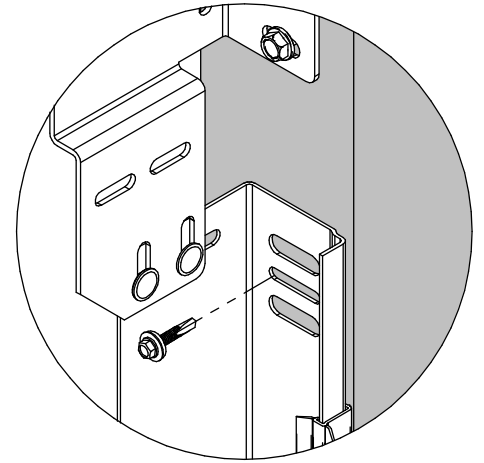
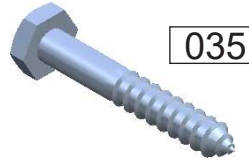

Φ6

8011

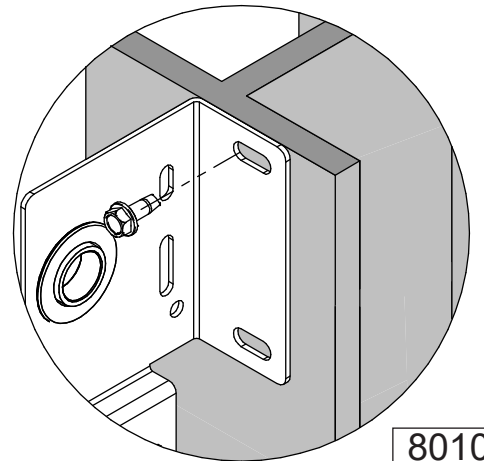
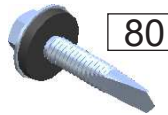

Φ8

8010

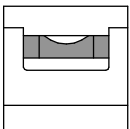
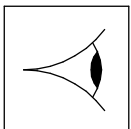

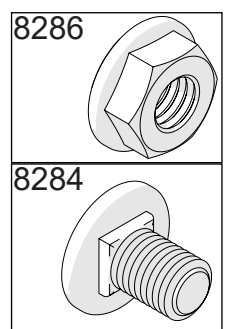
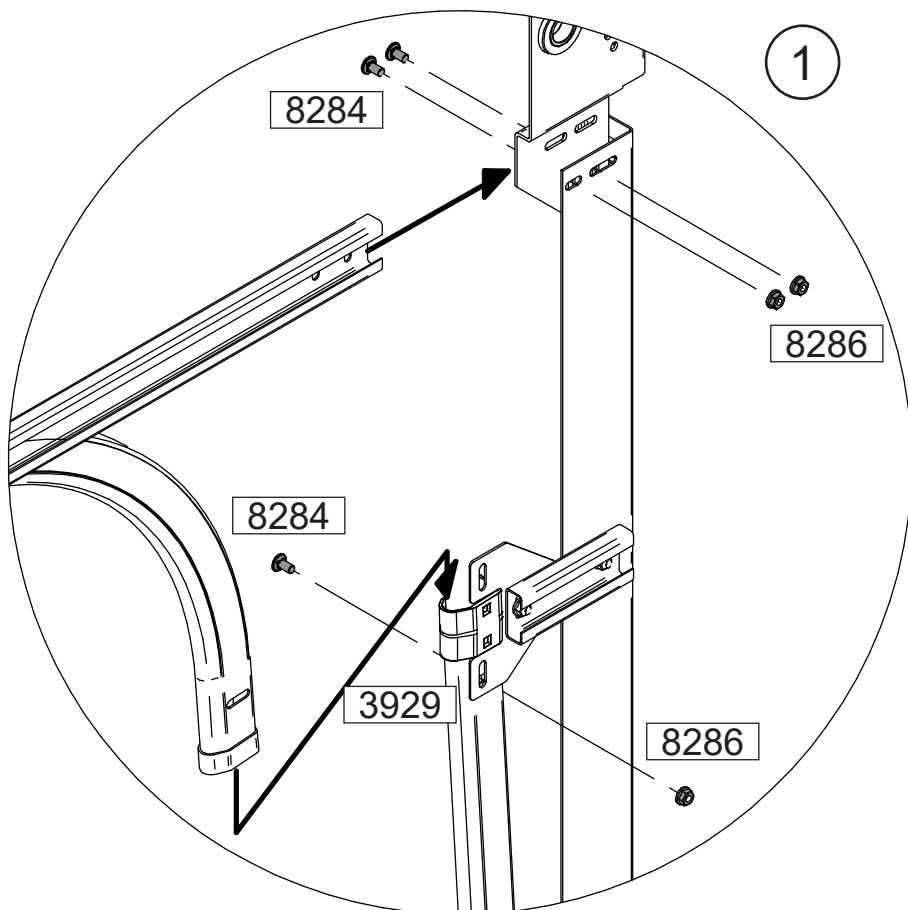
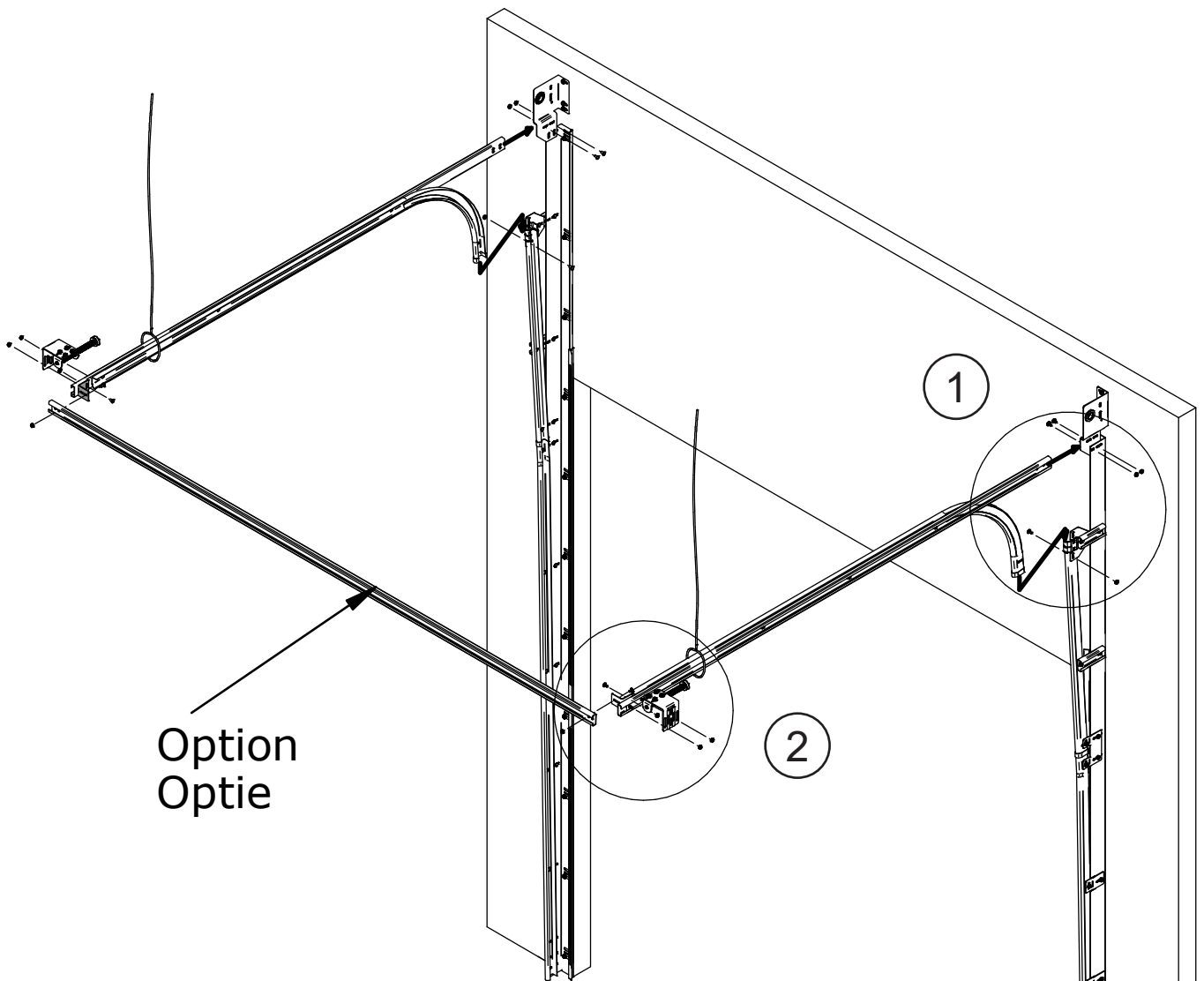

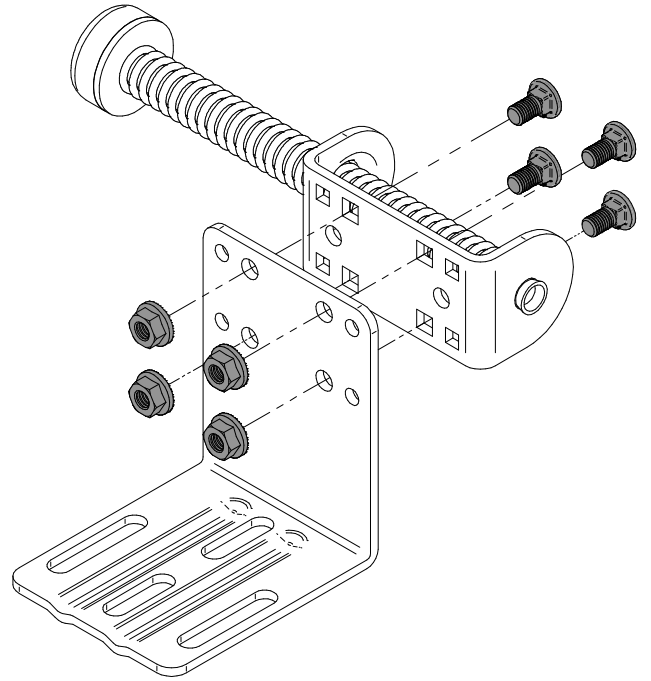
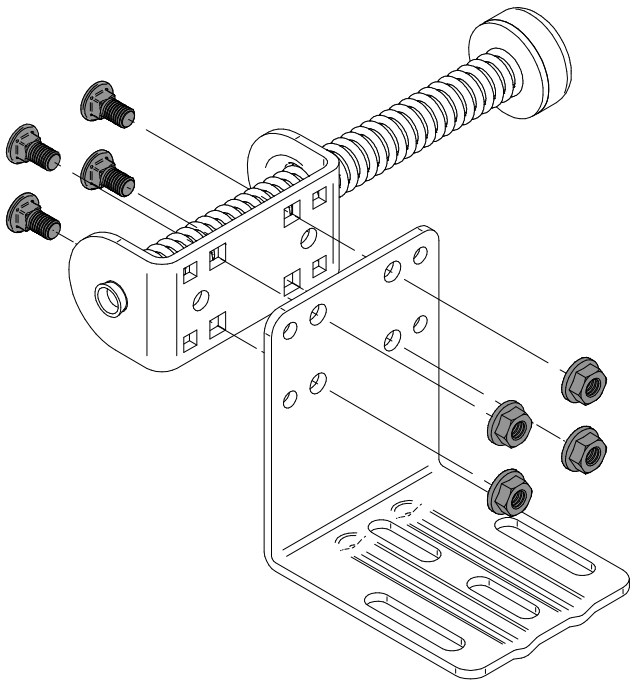

2

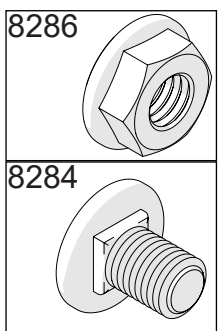
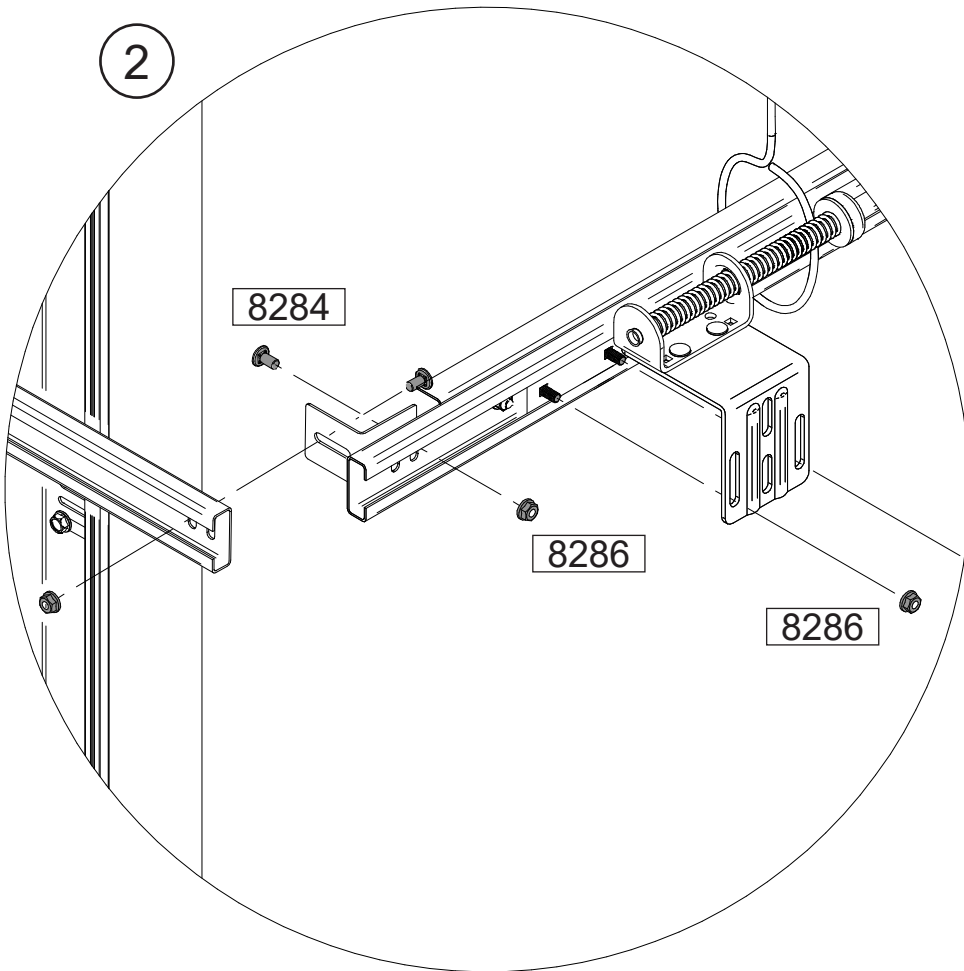

Following the roof
Daklijn volgend
Dachfolge
Avec Pente

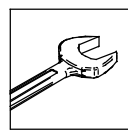
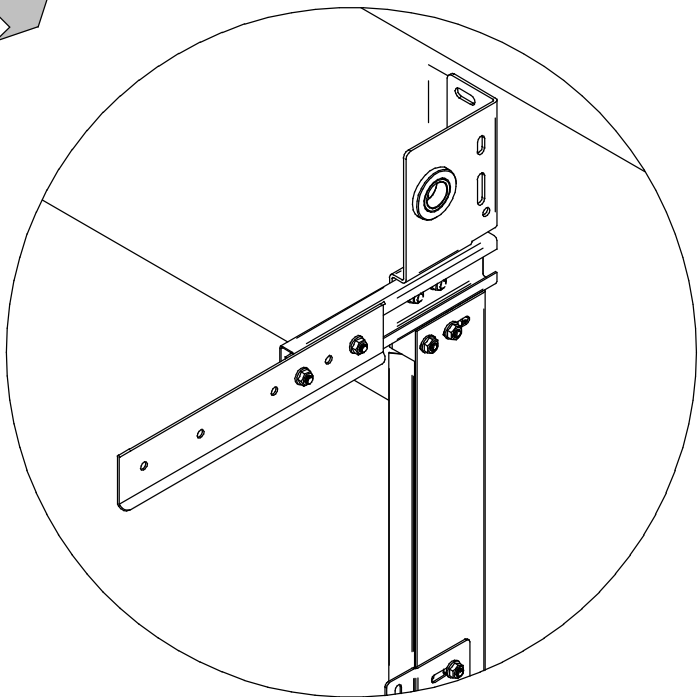
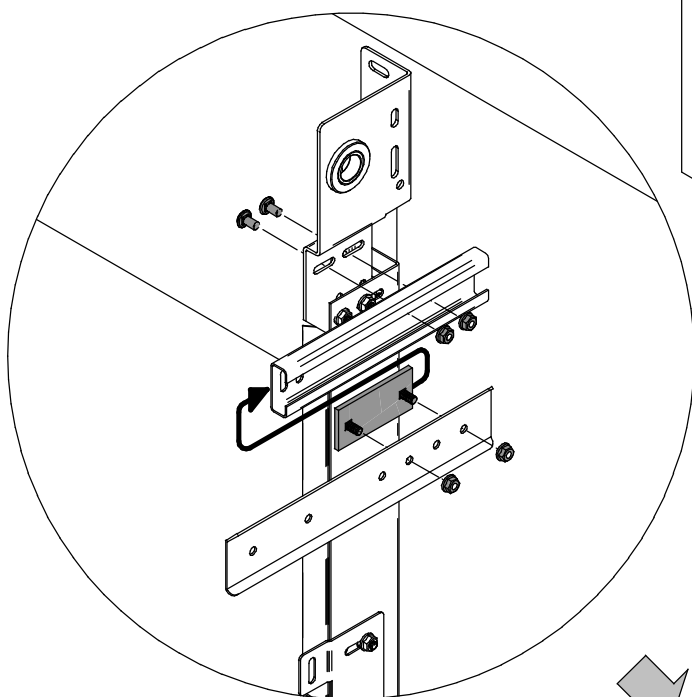
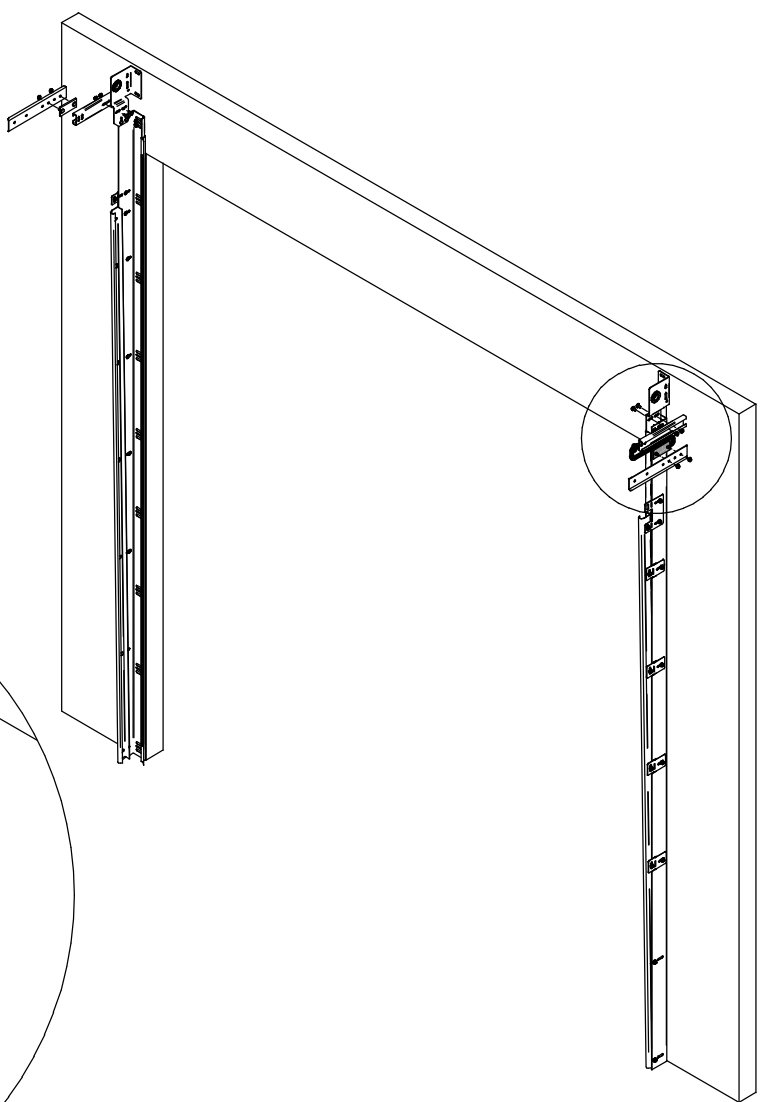

Following the roof
Daklijn volgend
Dachfolge
Avec Pente

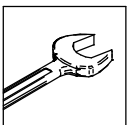
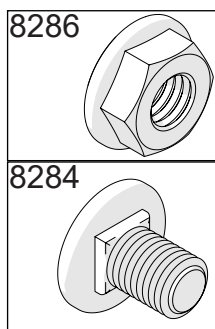
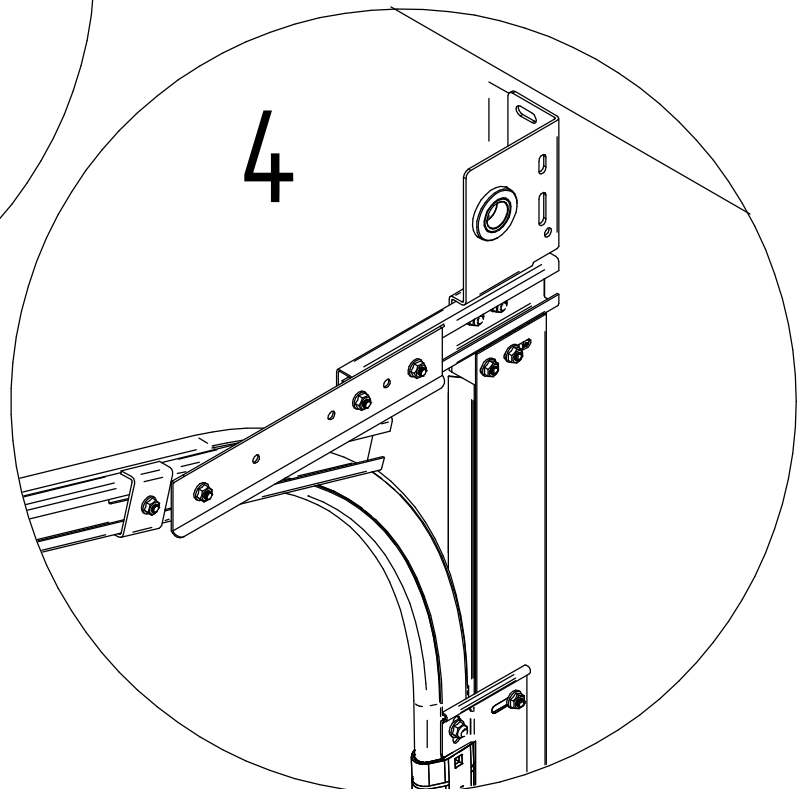
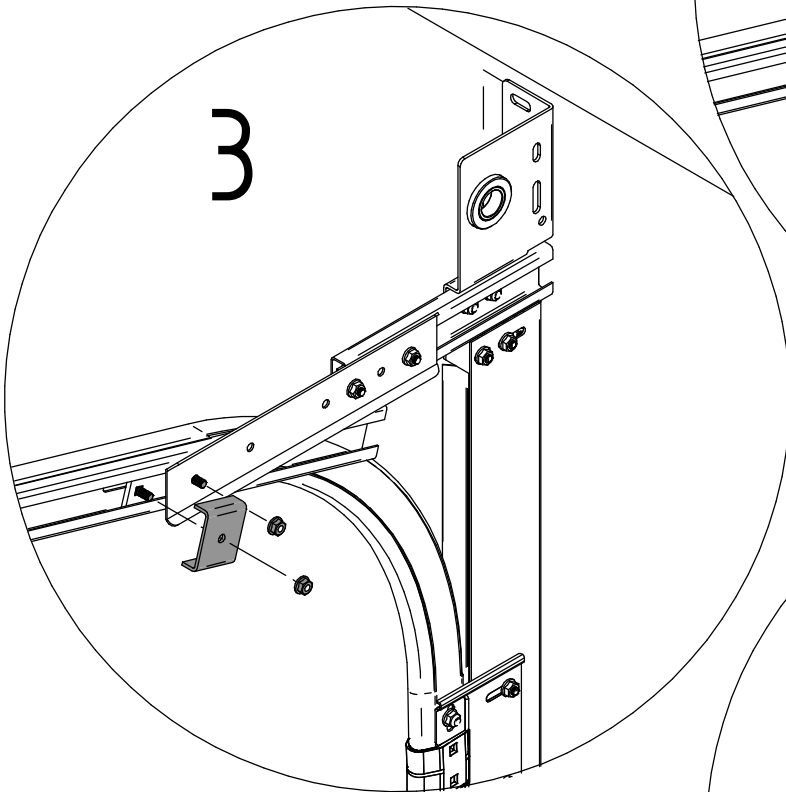
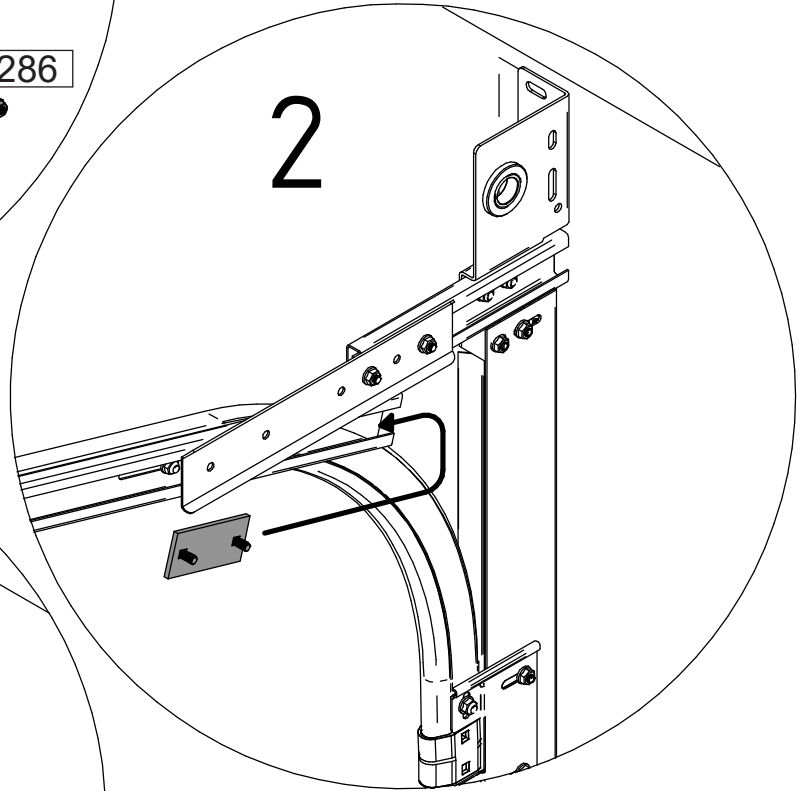
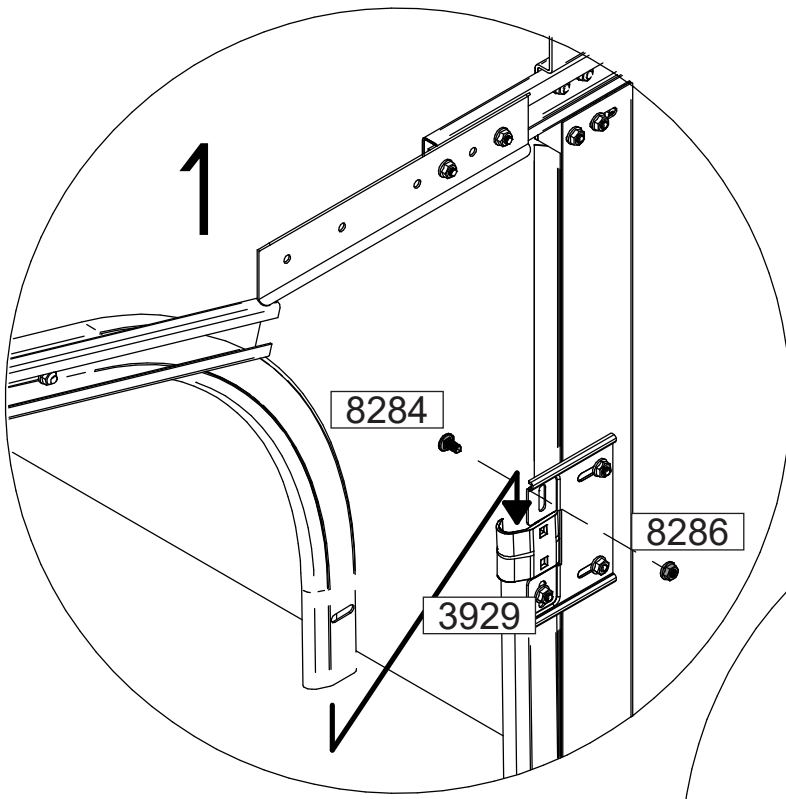

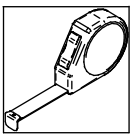
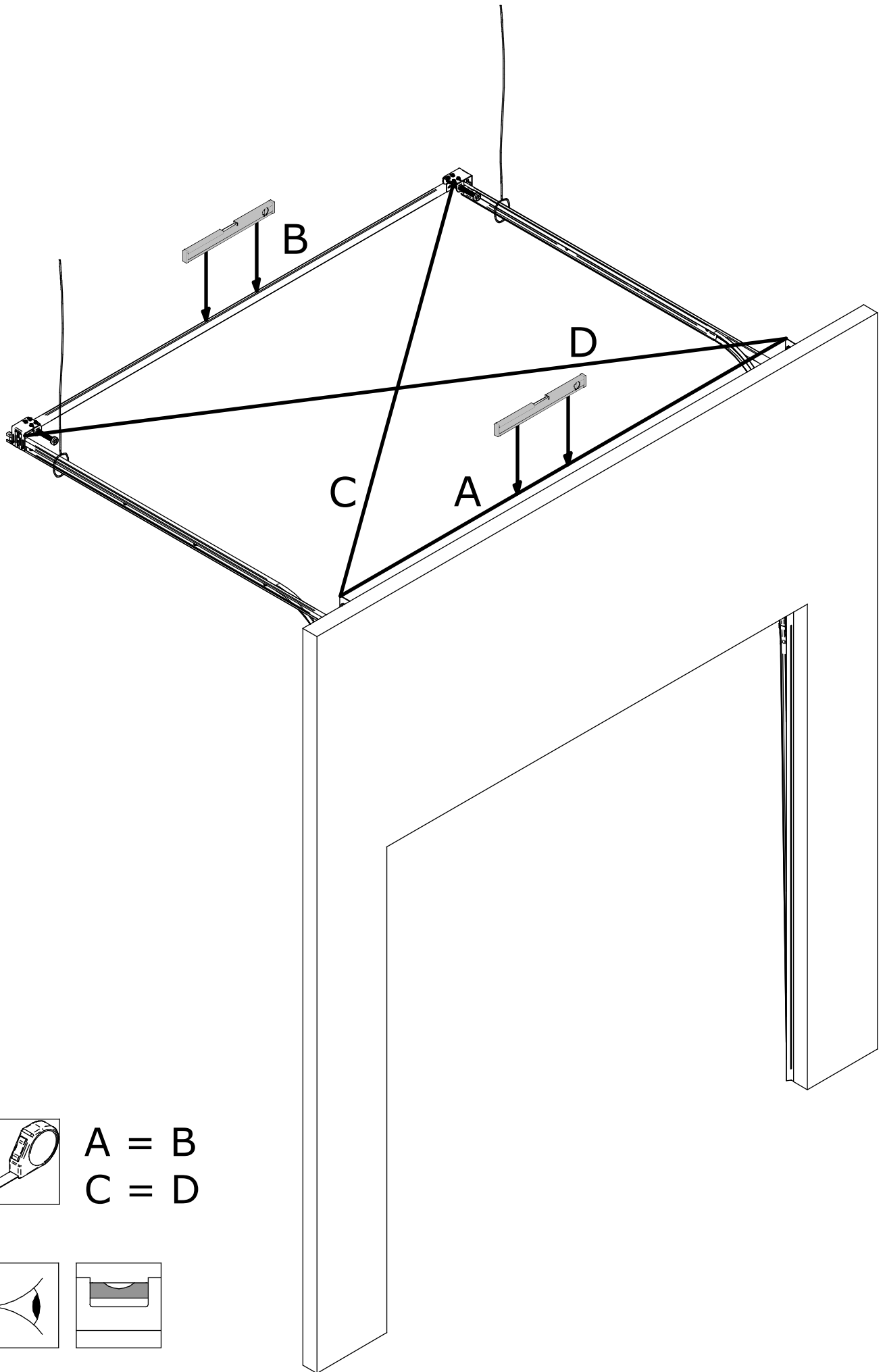

$A = B$
 $C = D$

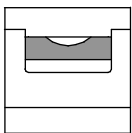
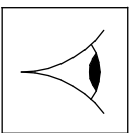

HS

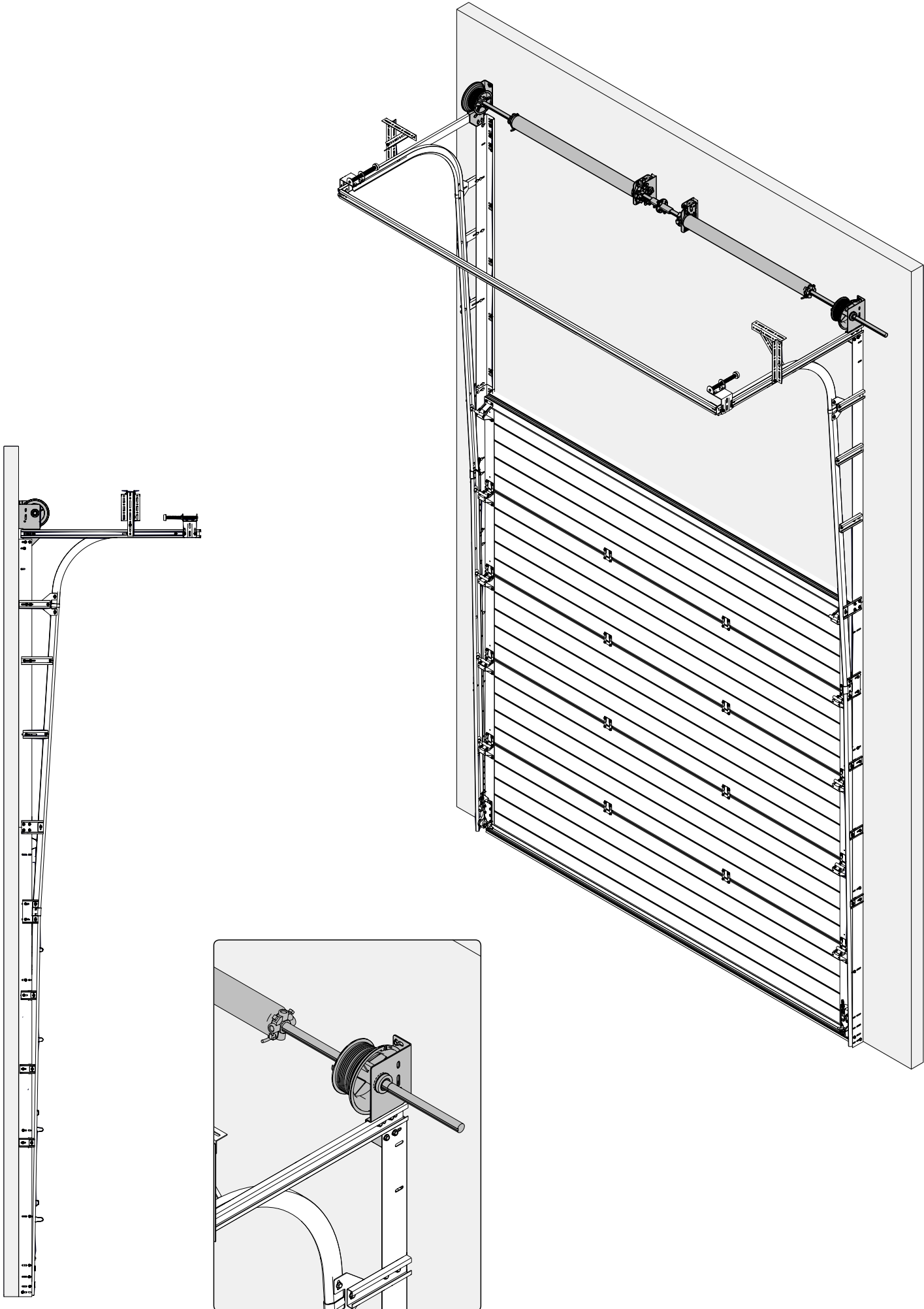

HSK Standaard / Standard / Au linteau

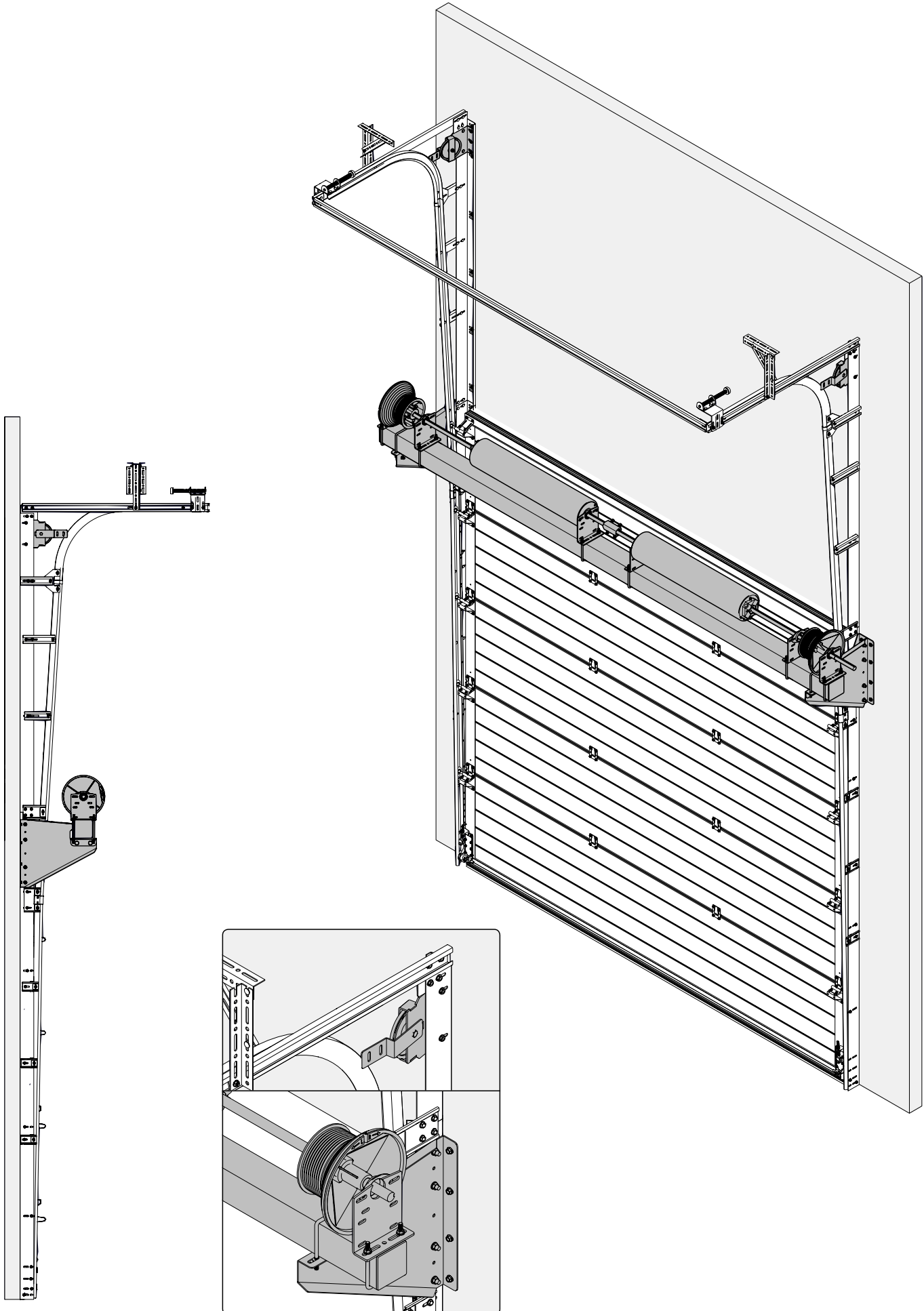

HSK SBD position

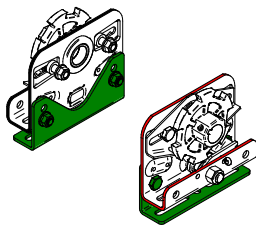
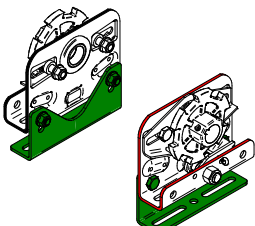
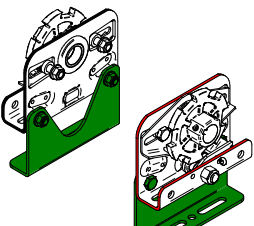
<p>2 Springs + 4 Springs outside springs</p>			
	<p>111 - 3164</p>	<p>127 - 3164</p>	<p>152 - 3165</p>

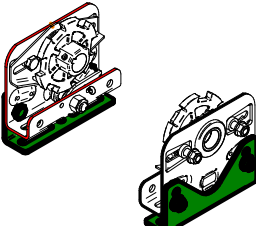
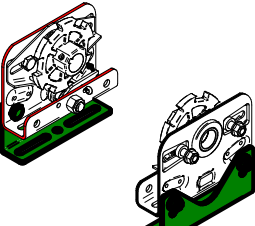
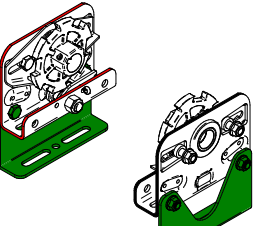
<p>4 Springs inside springs</p>			
	<p>111 - 3164</p>	<p>127 - 3164</p>	<p>152 - 3165</p>

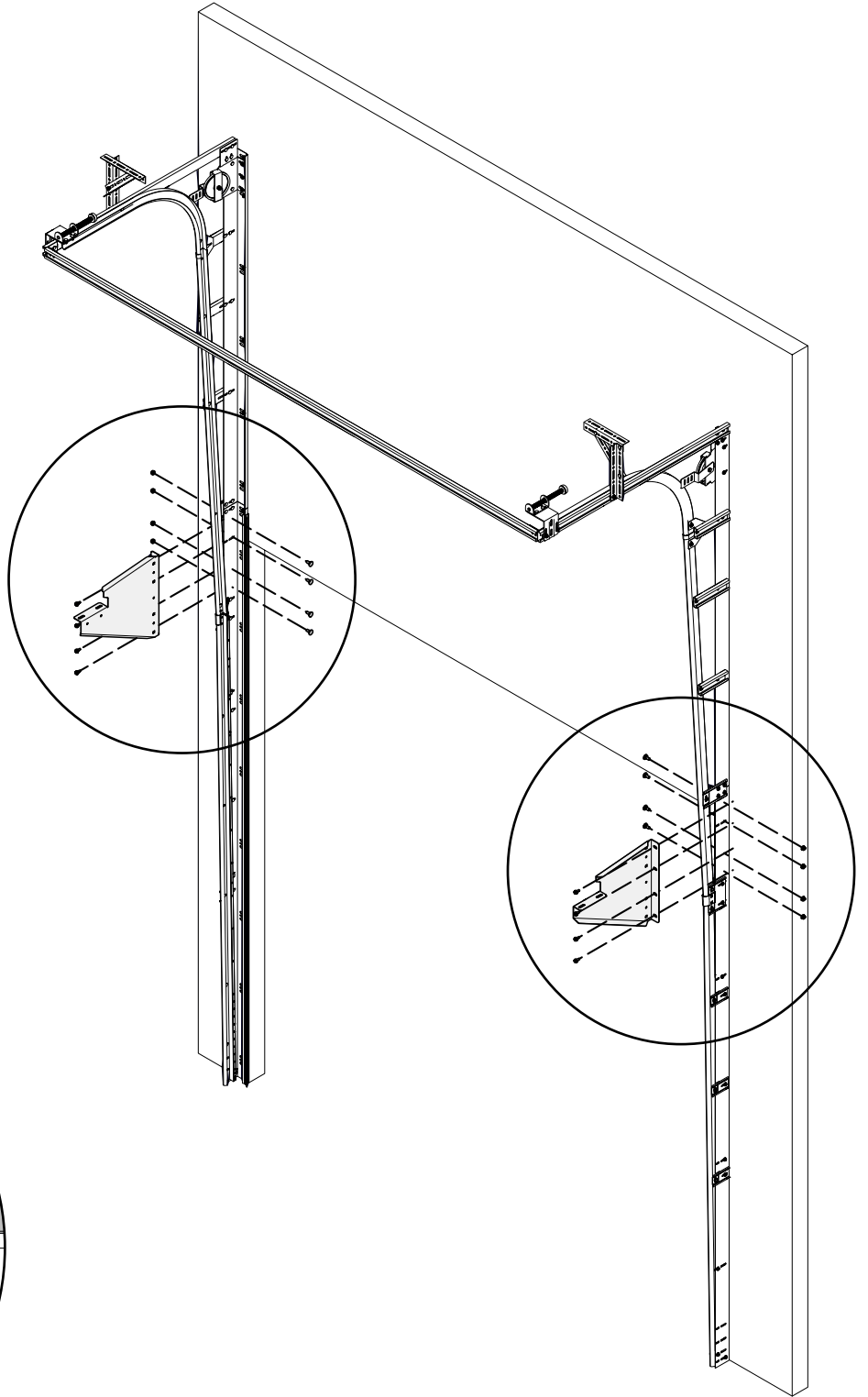
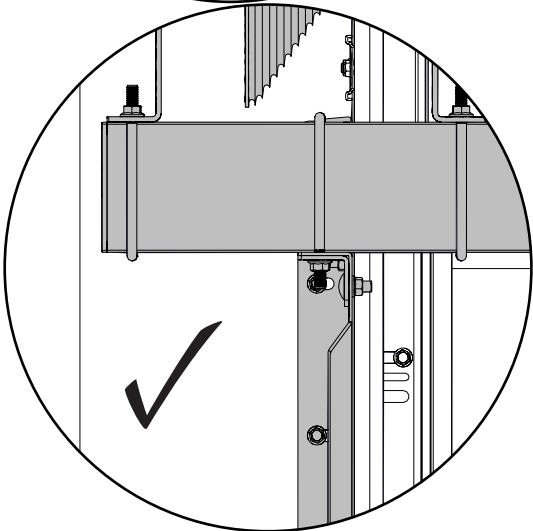
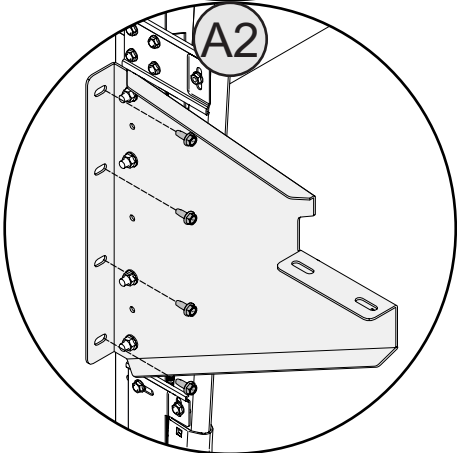
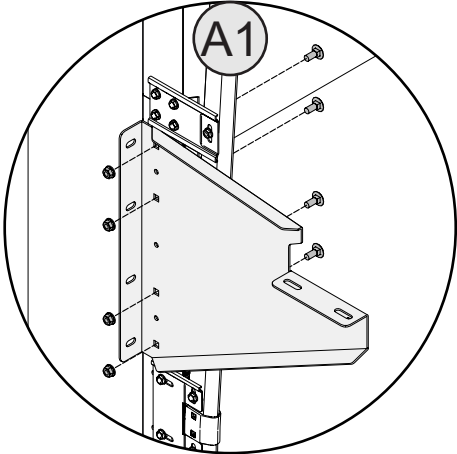
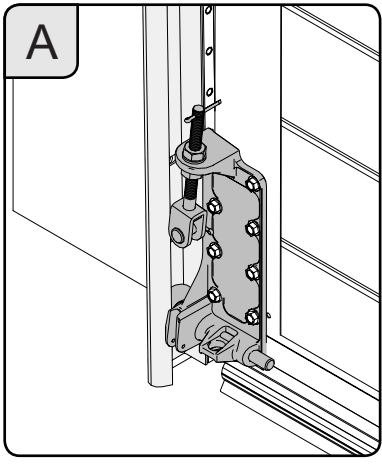

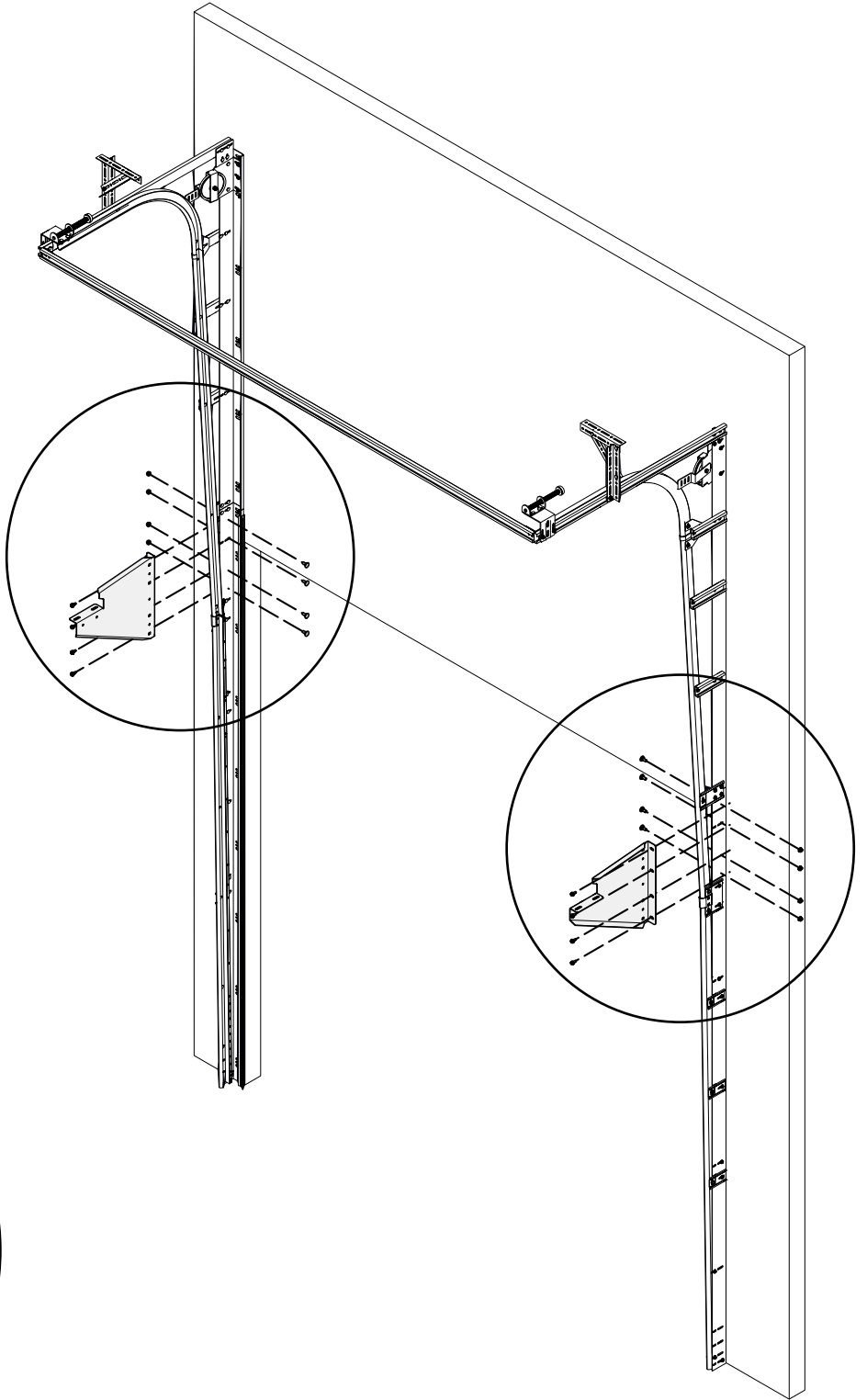
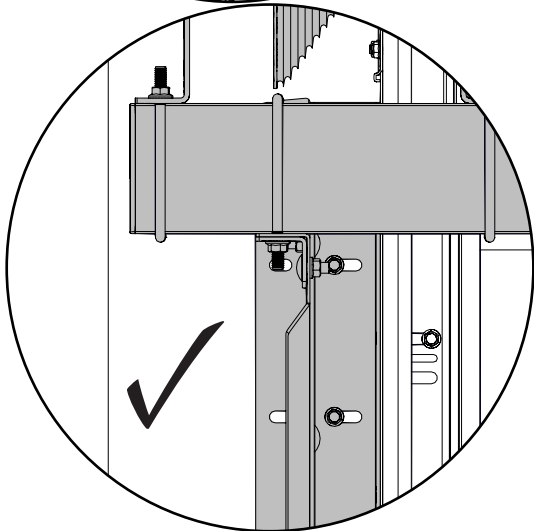
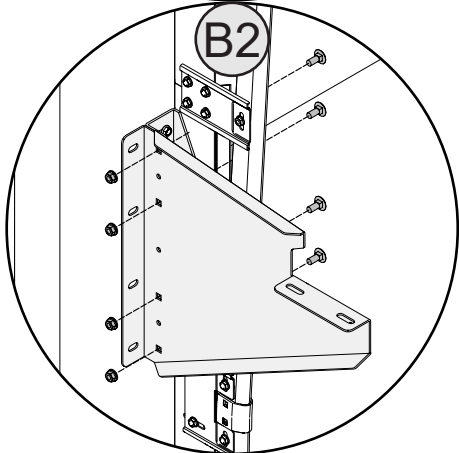
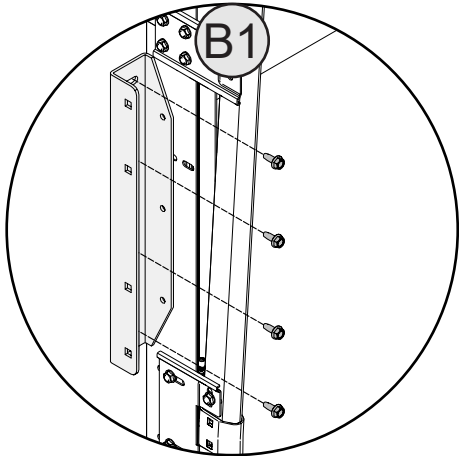
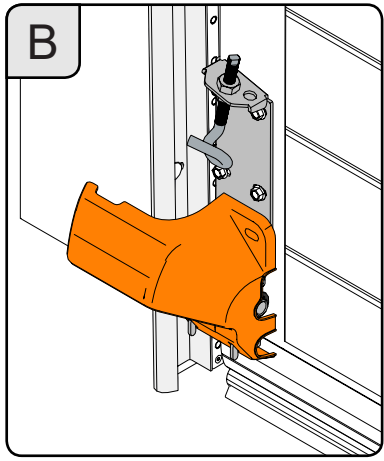

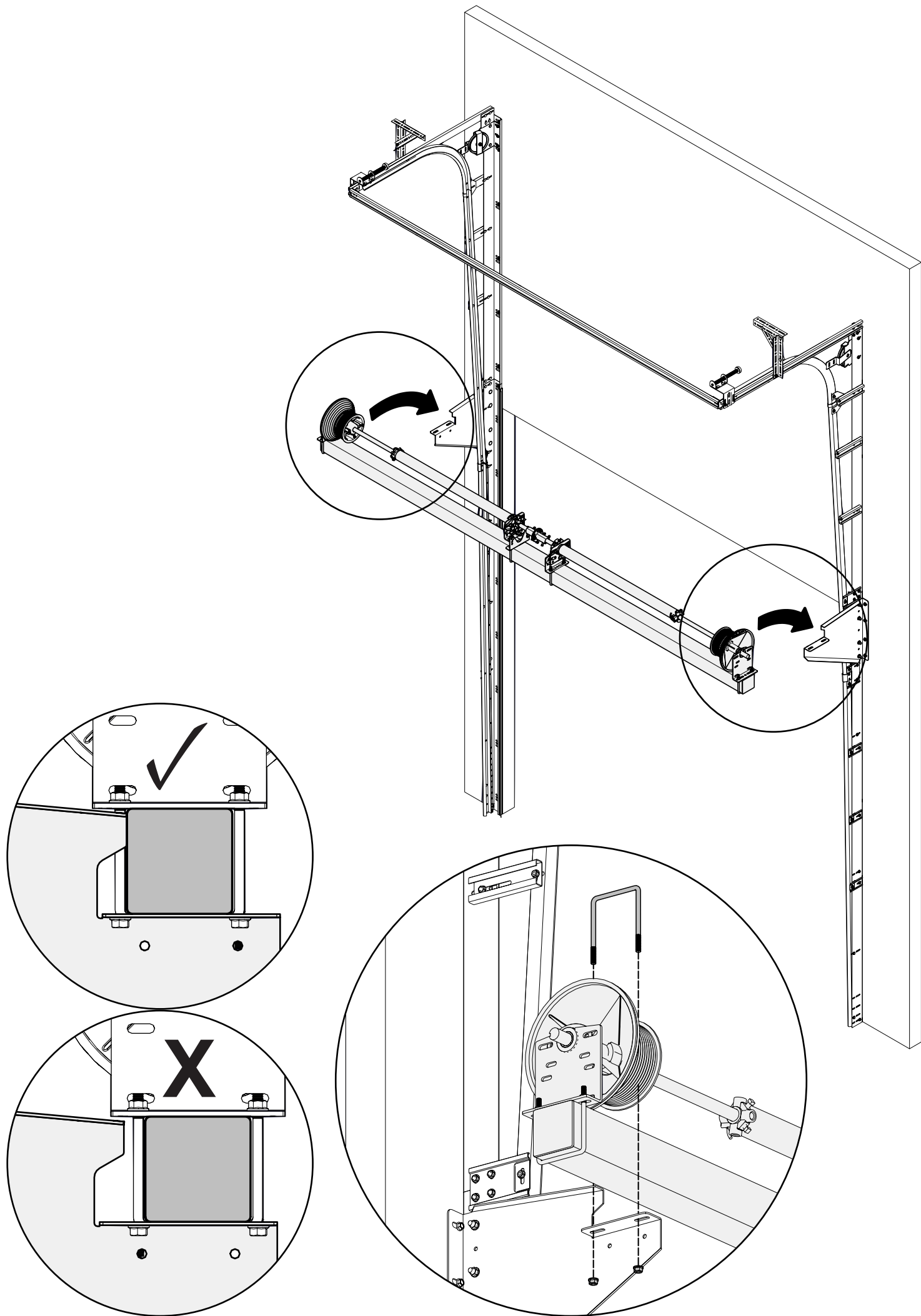

HSK Top

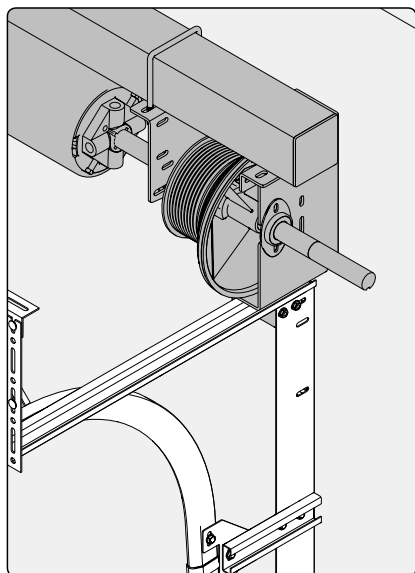
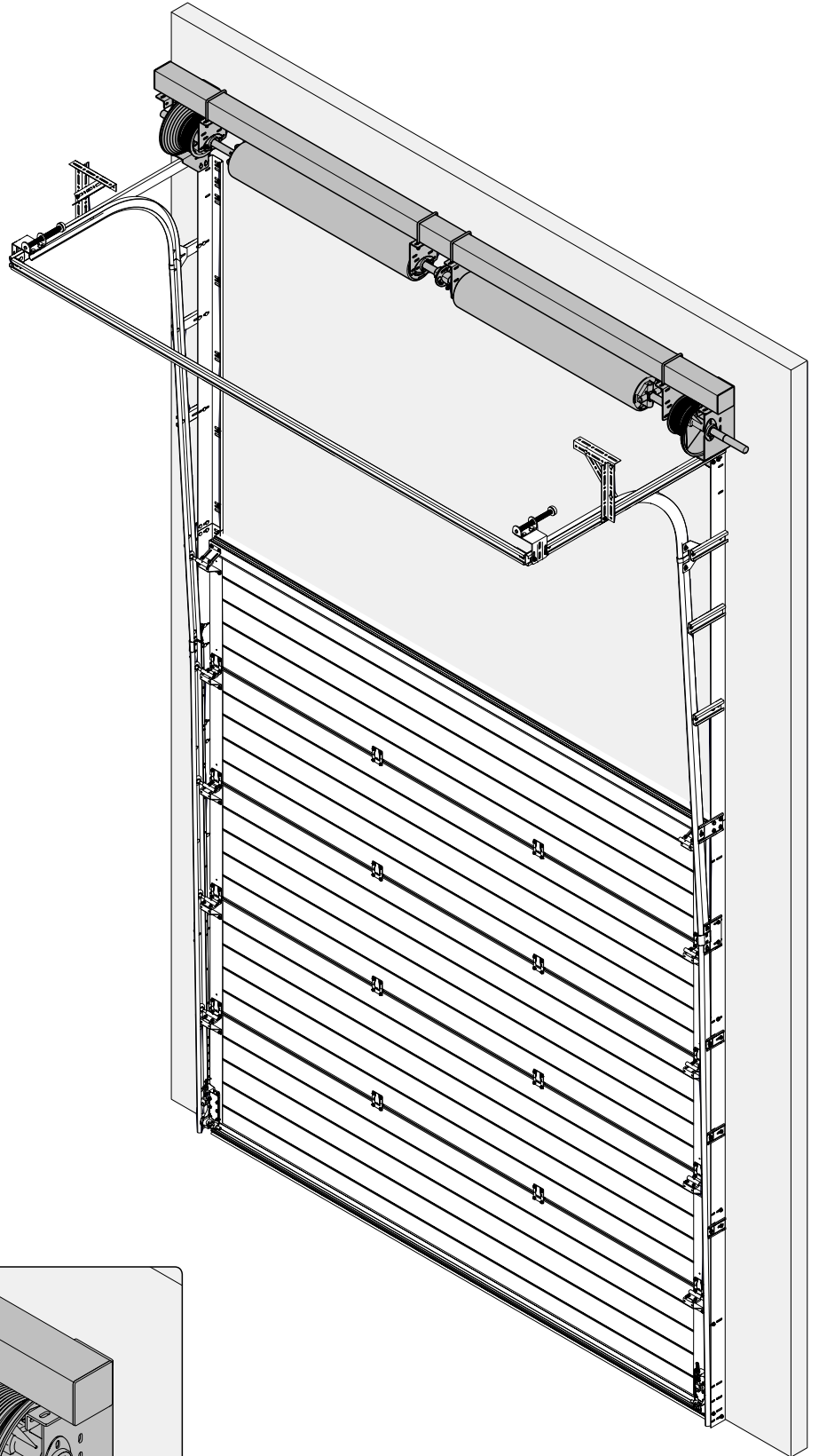
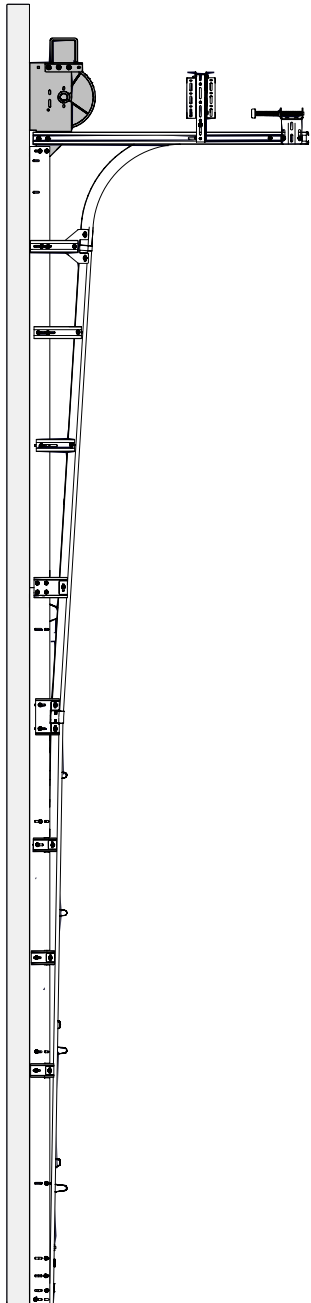

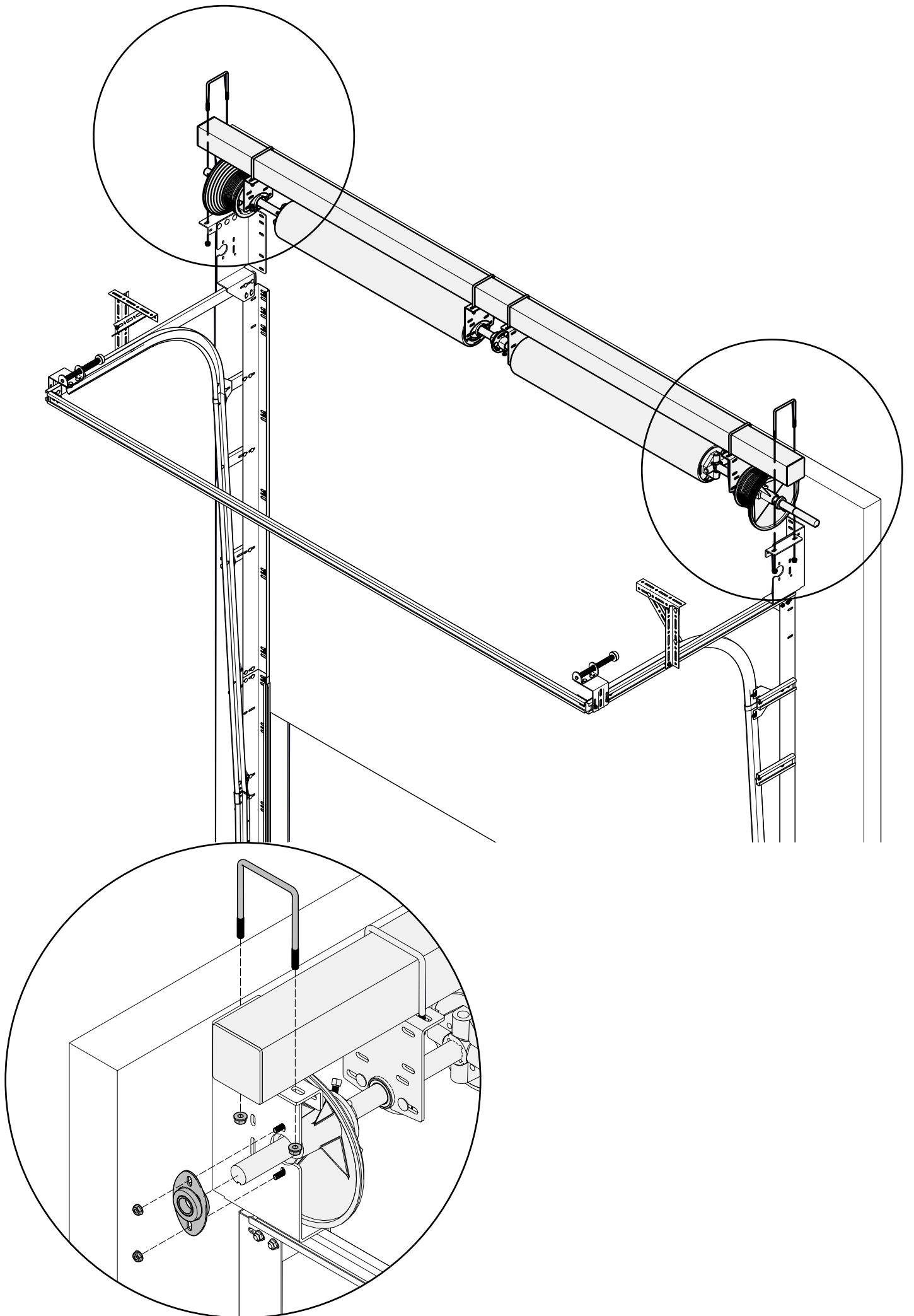

HSK Buitenom / Aussen / Outside / Au linteau câble à l'ext

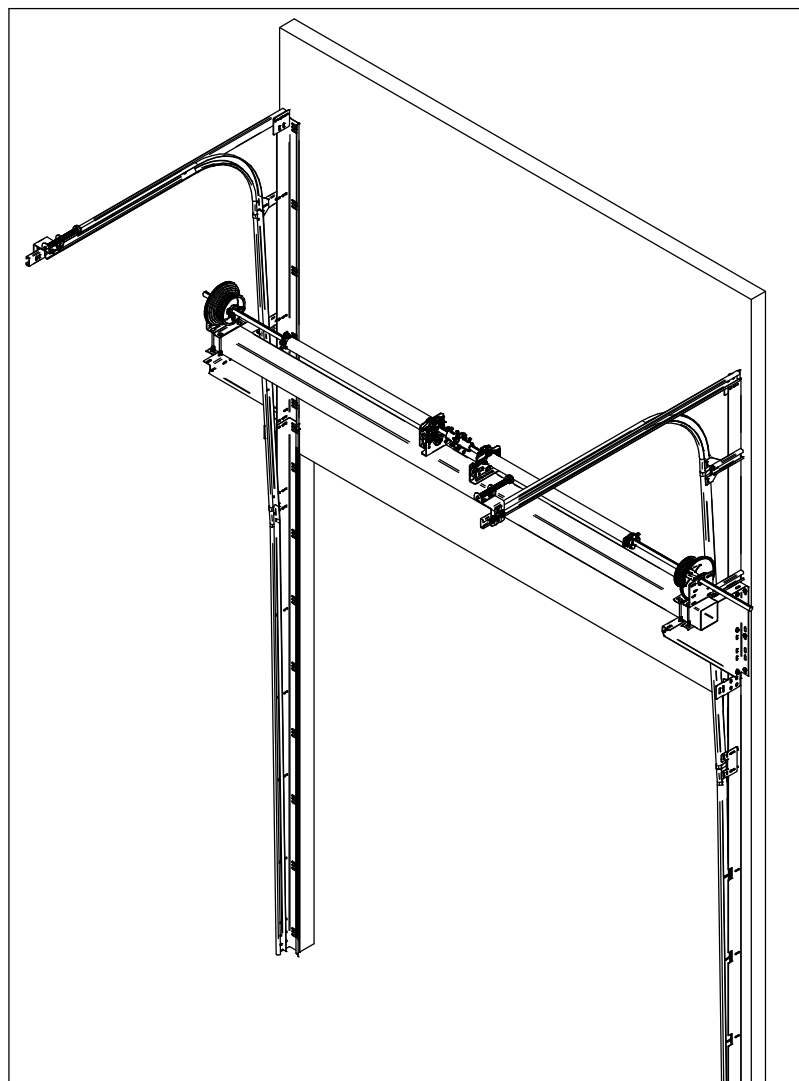
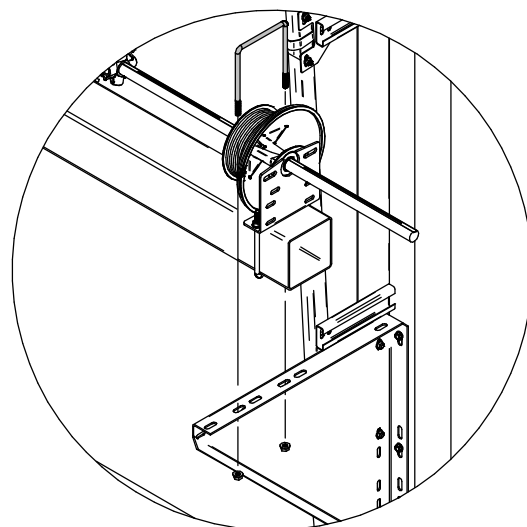
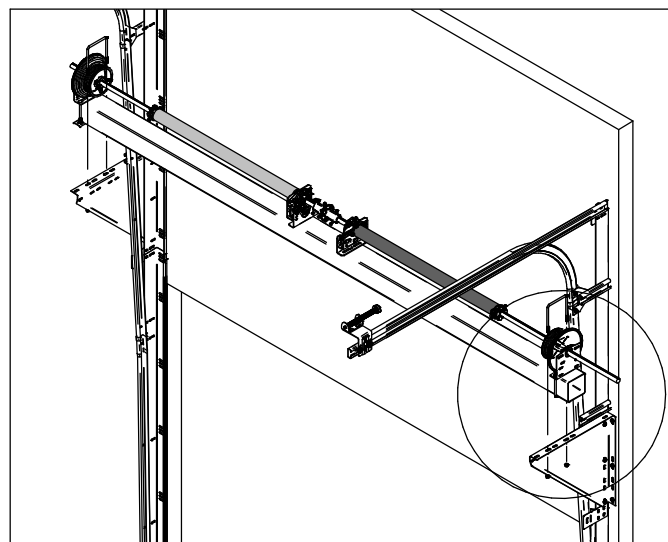
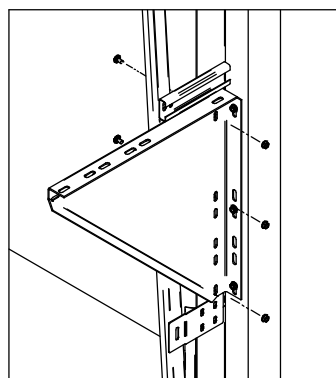
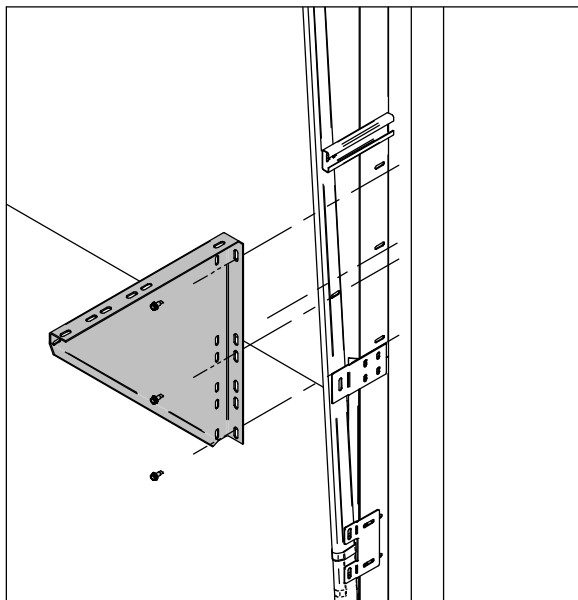

LHW

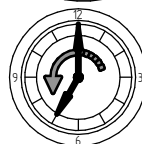
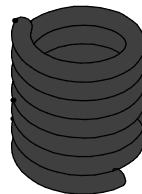

RHW

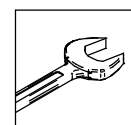
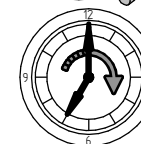
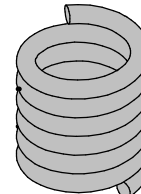

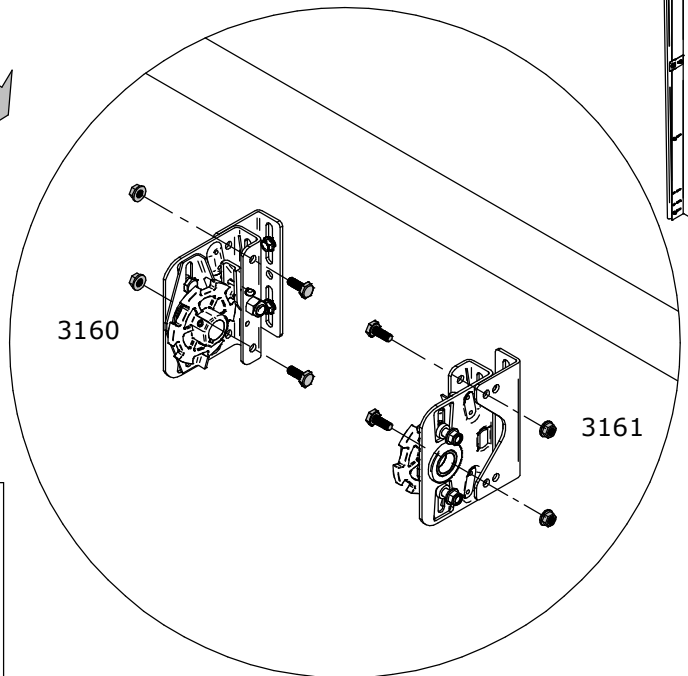
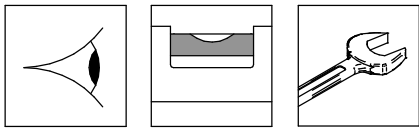
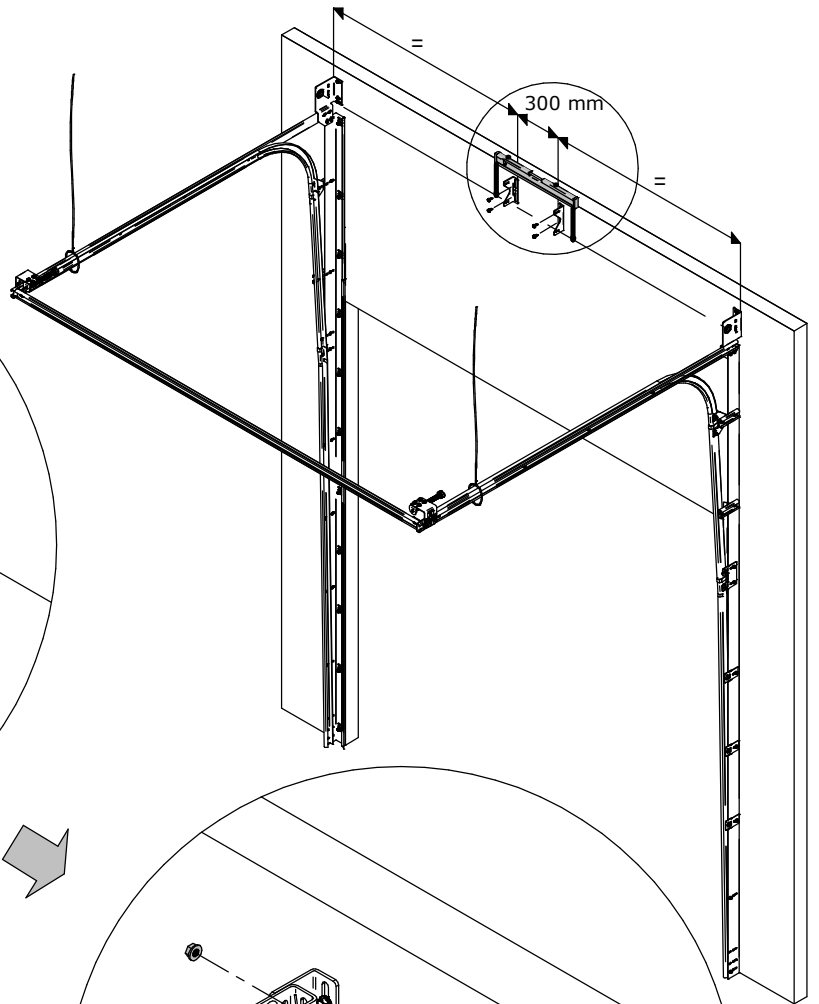
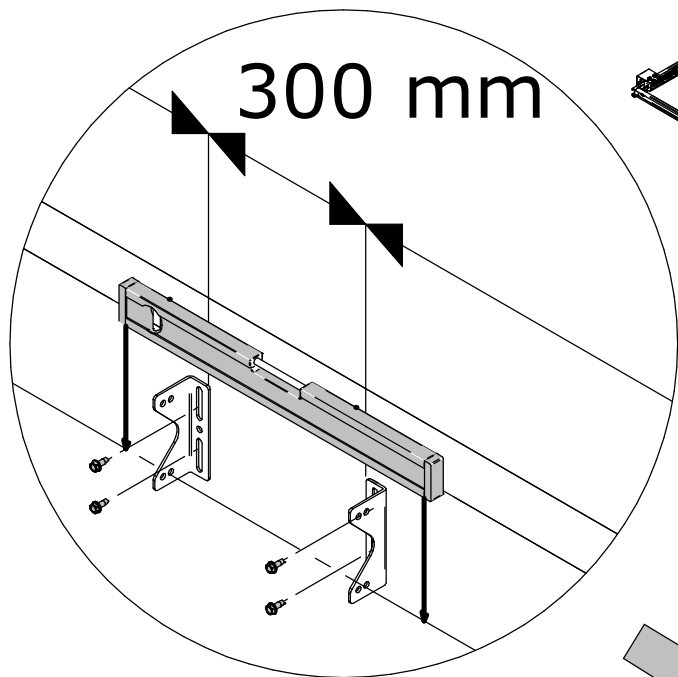

67 mm
95 mm

152 mm

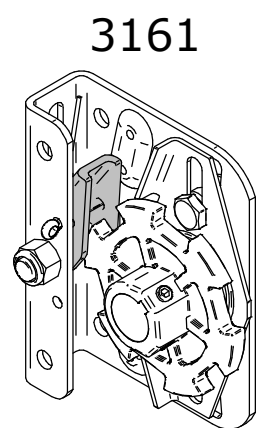
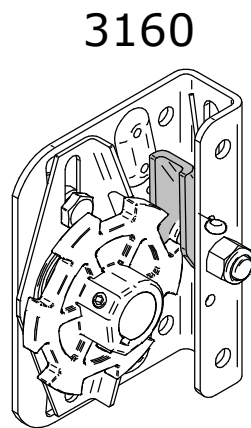

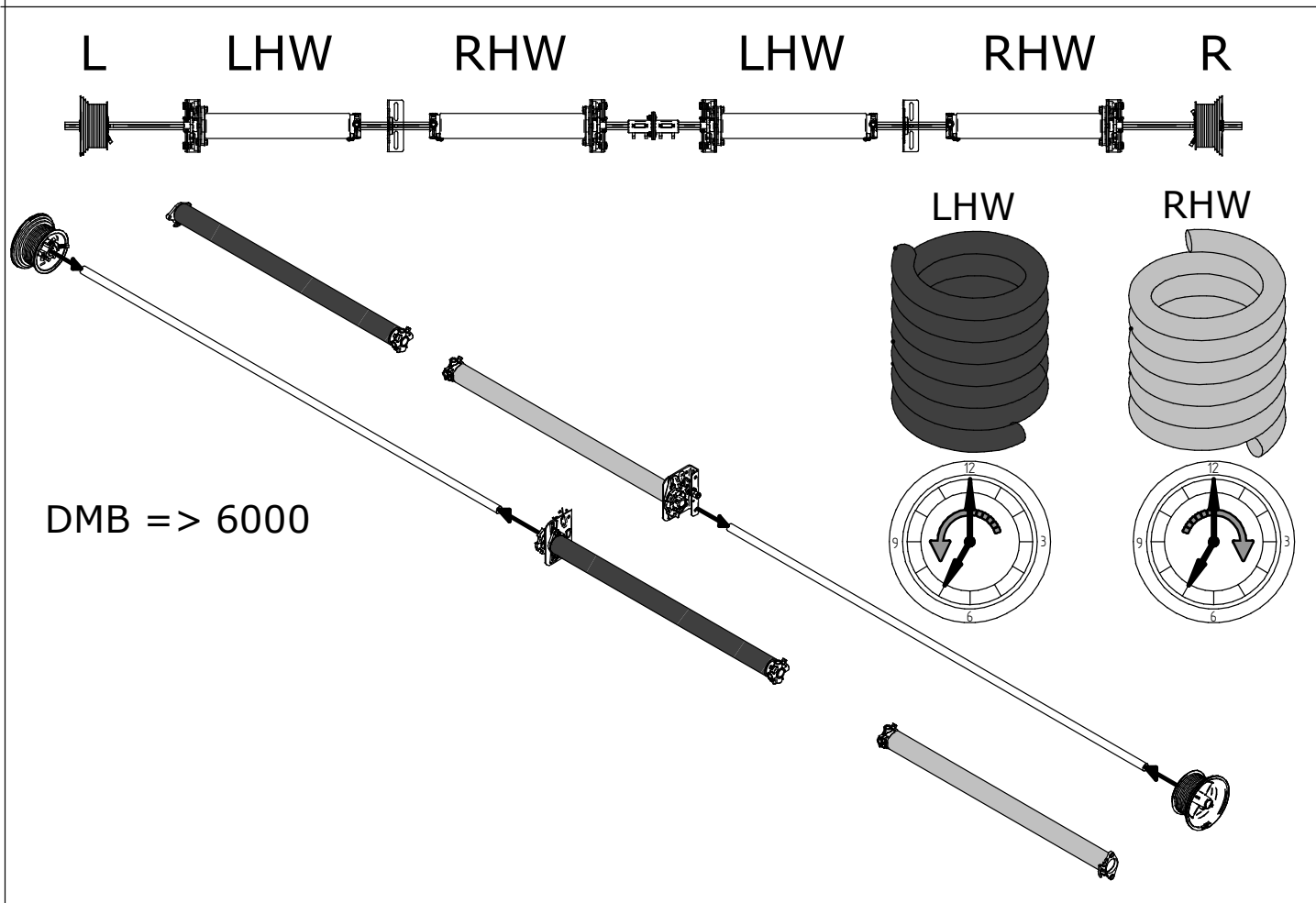
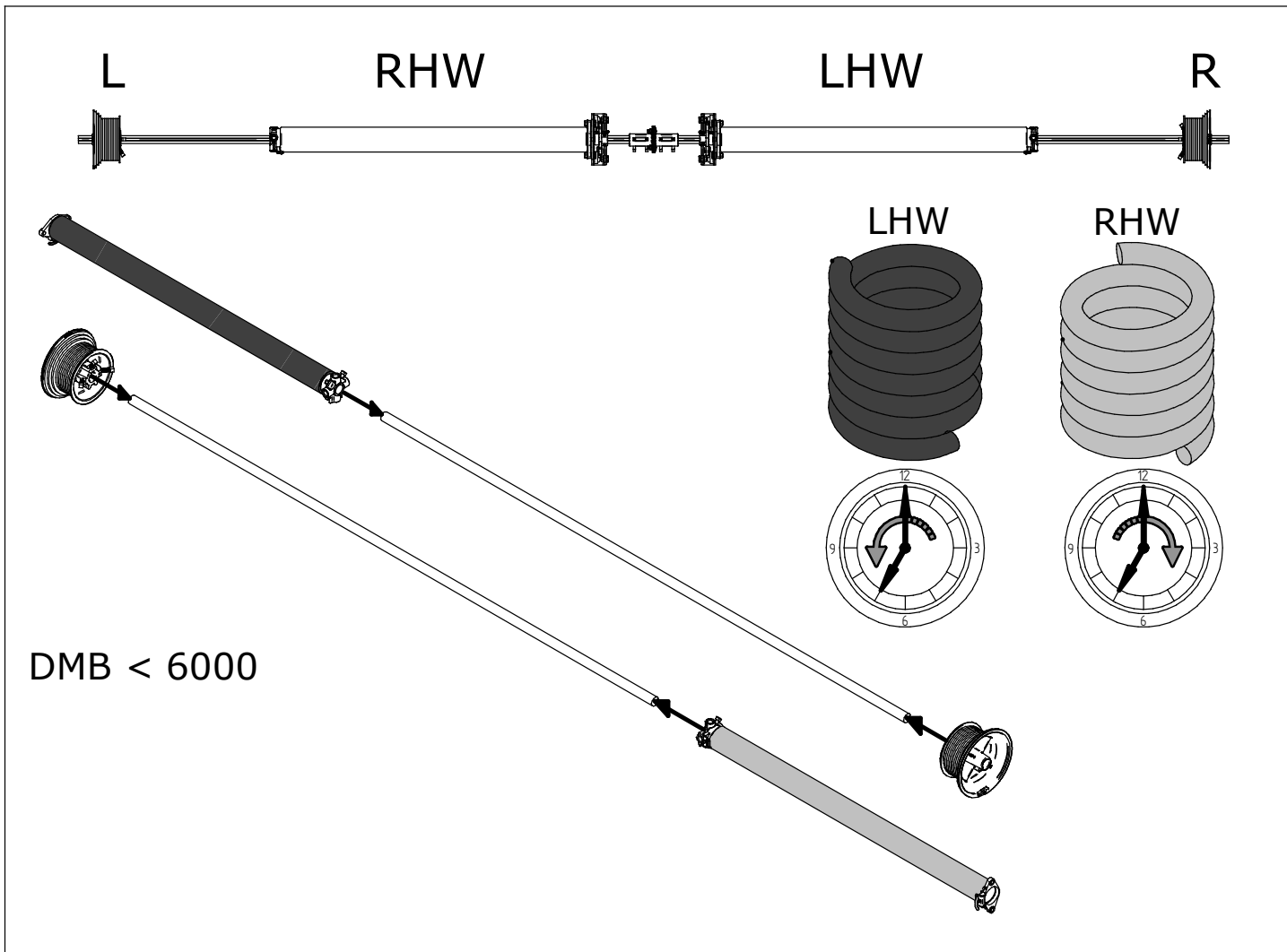

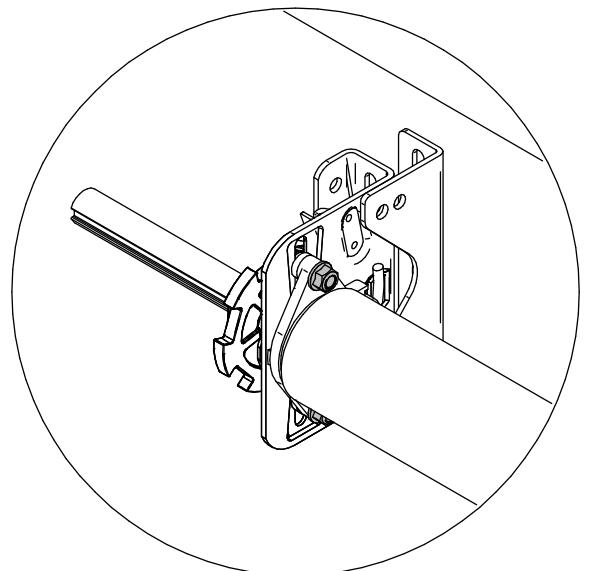
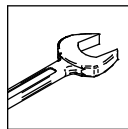
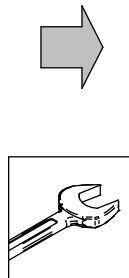
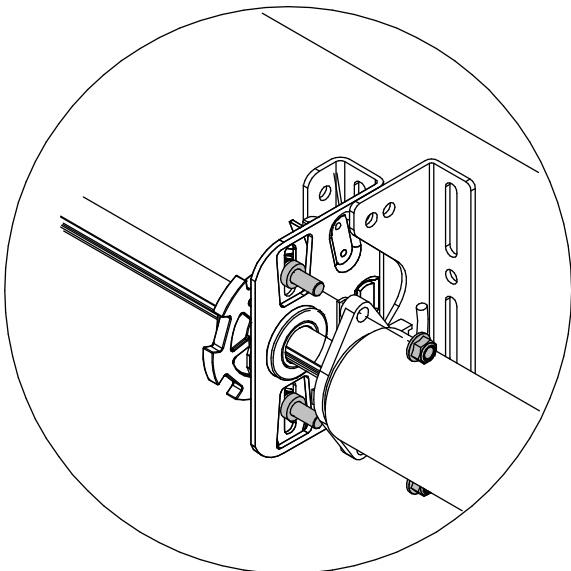
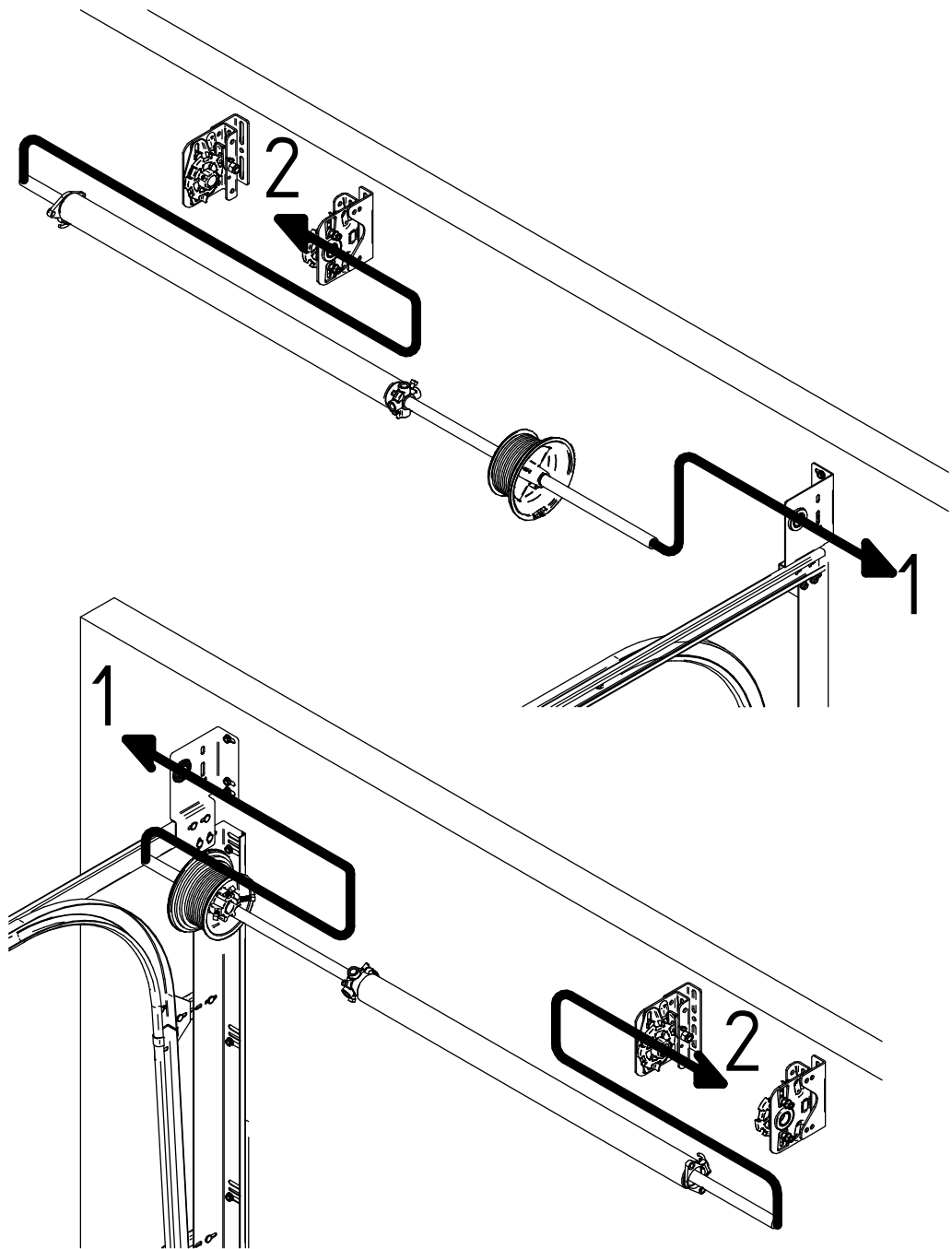

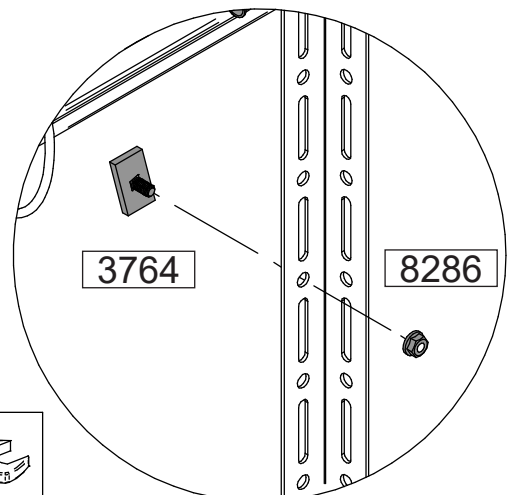
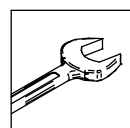
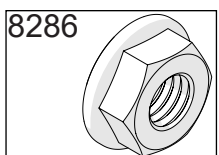
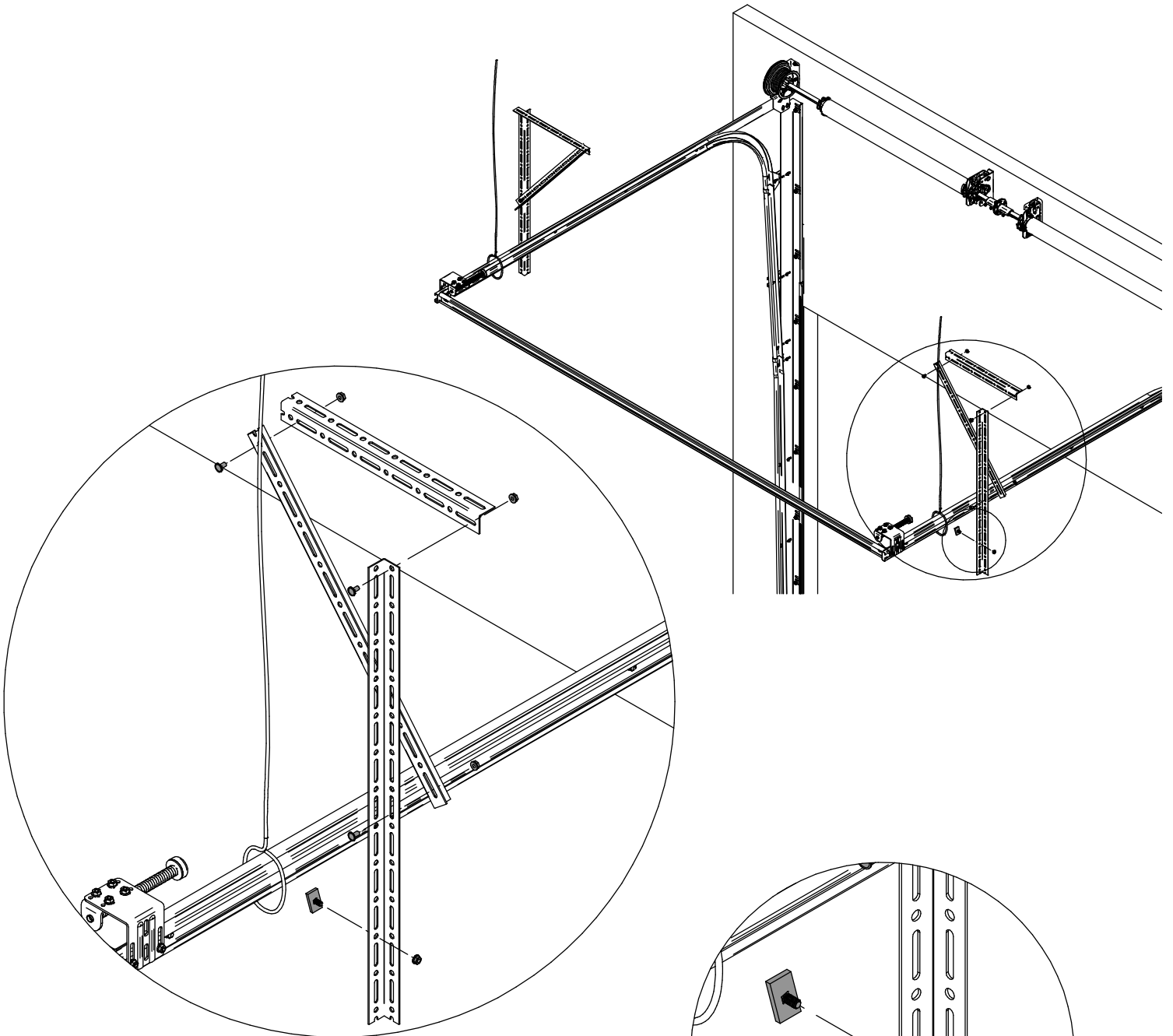
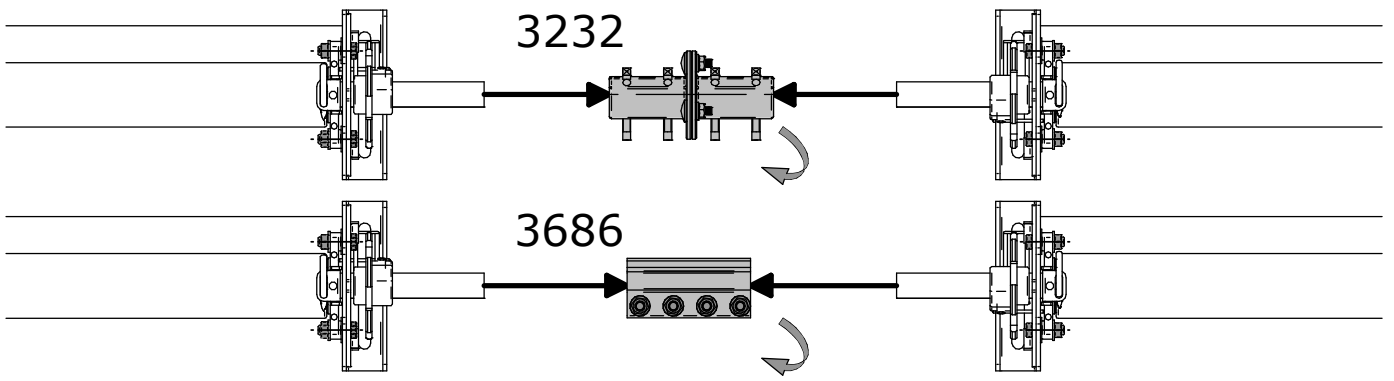

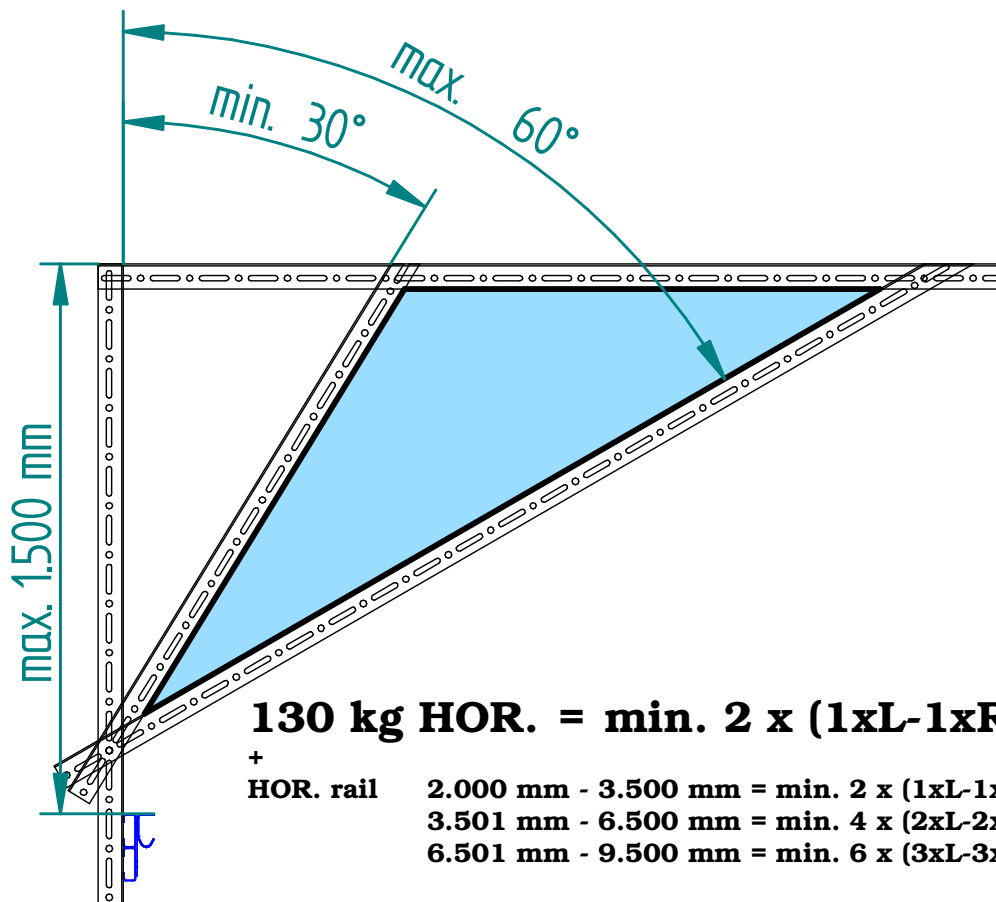
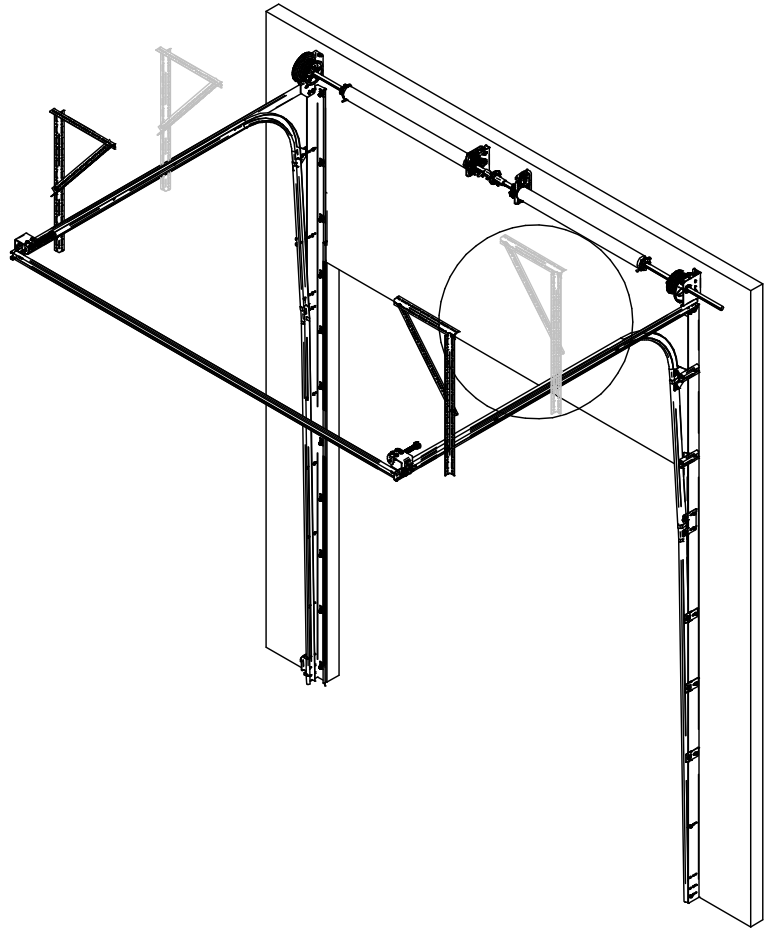
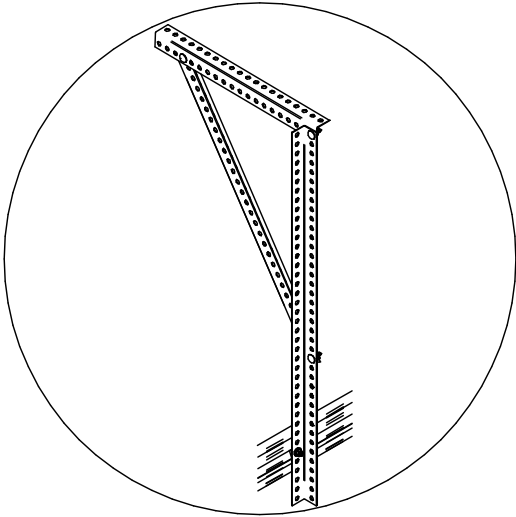

1

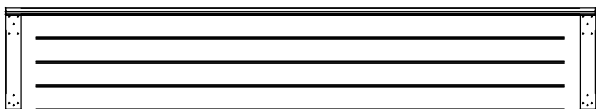

2

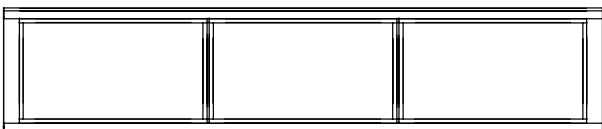

3

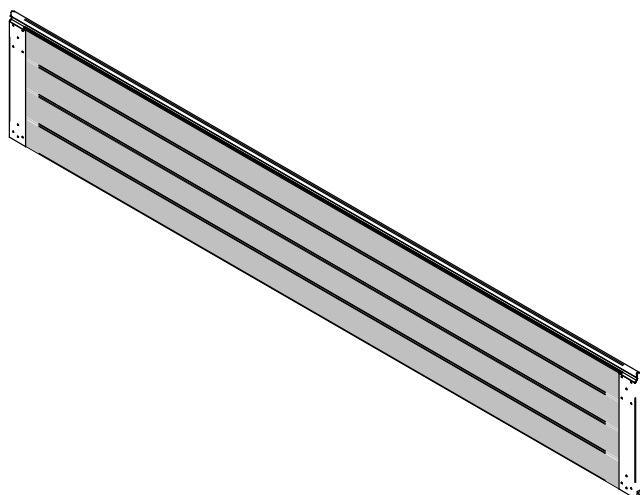
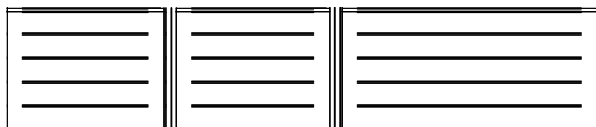

1

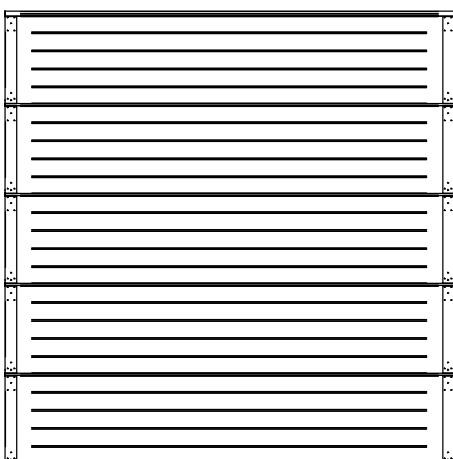

3

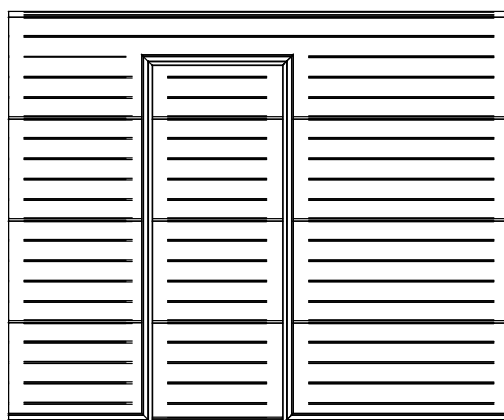

2

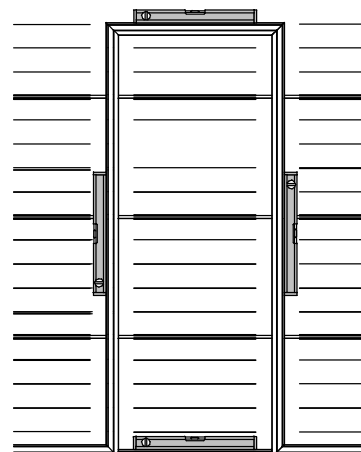
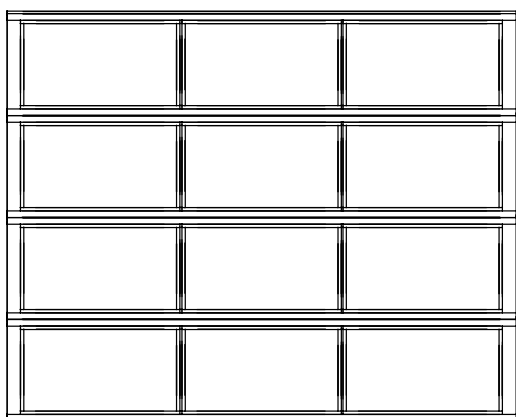

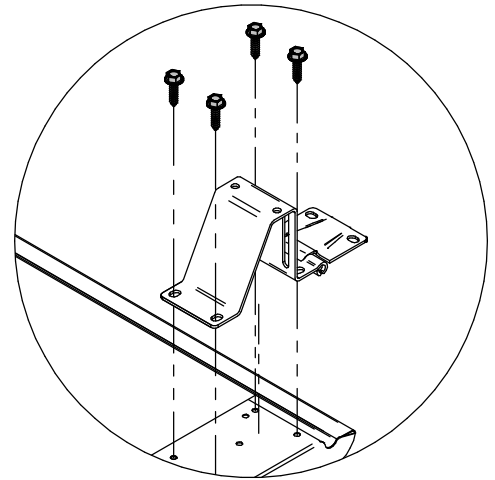
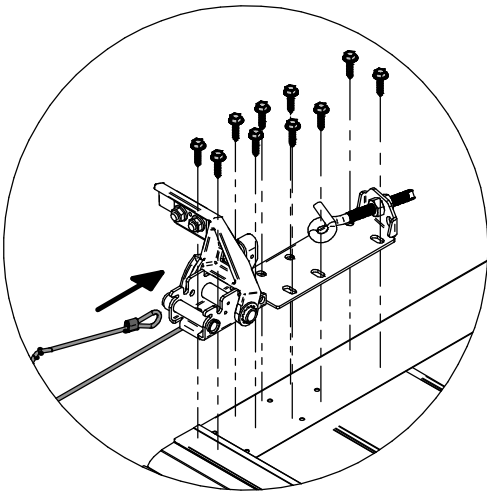
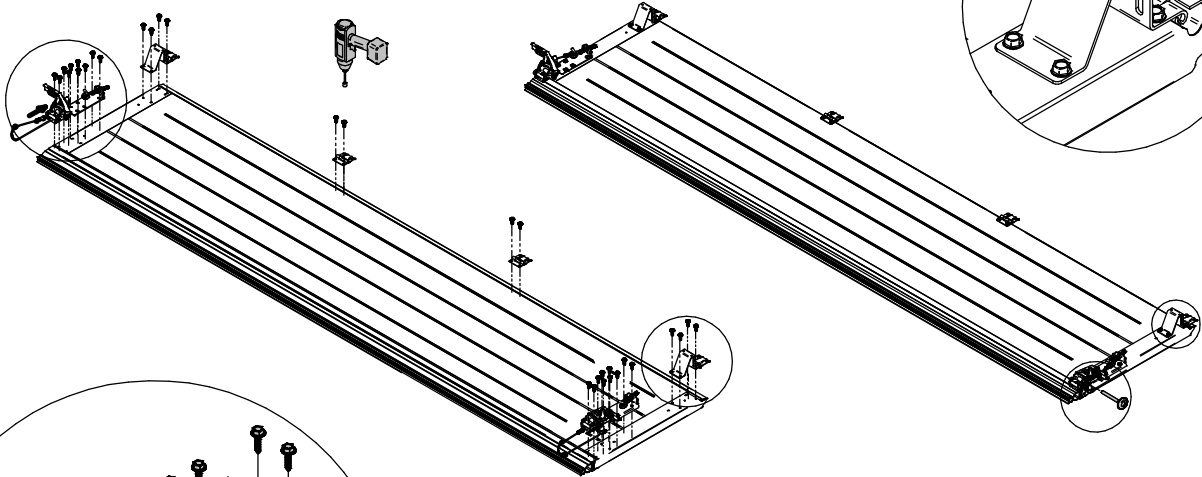
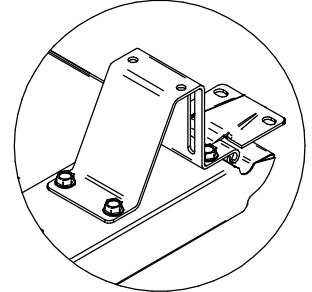
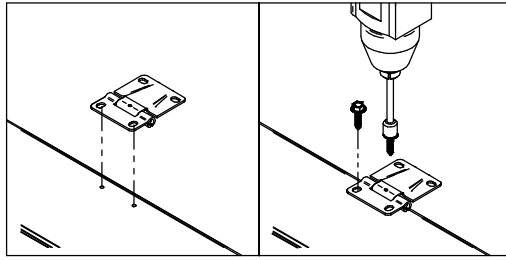
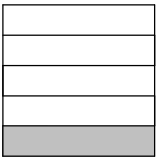

Options

3170 3184-3187 3194

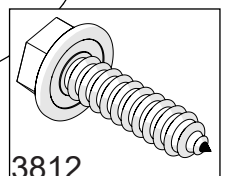
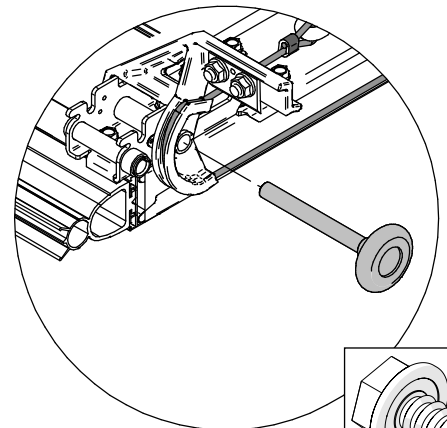

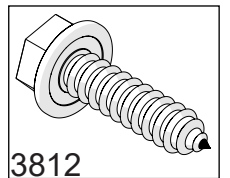
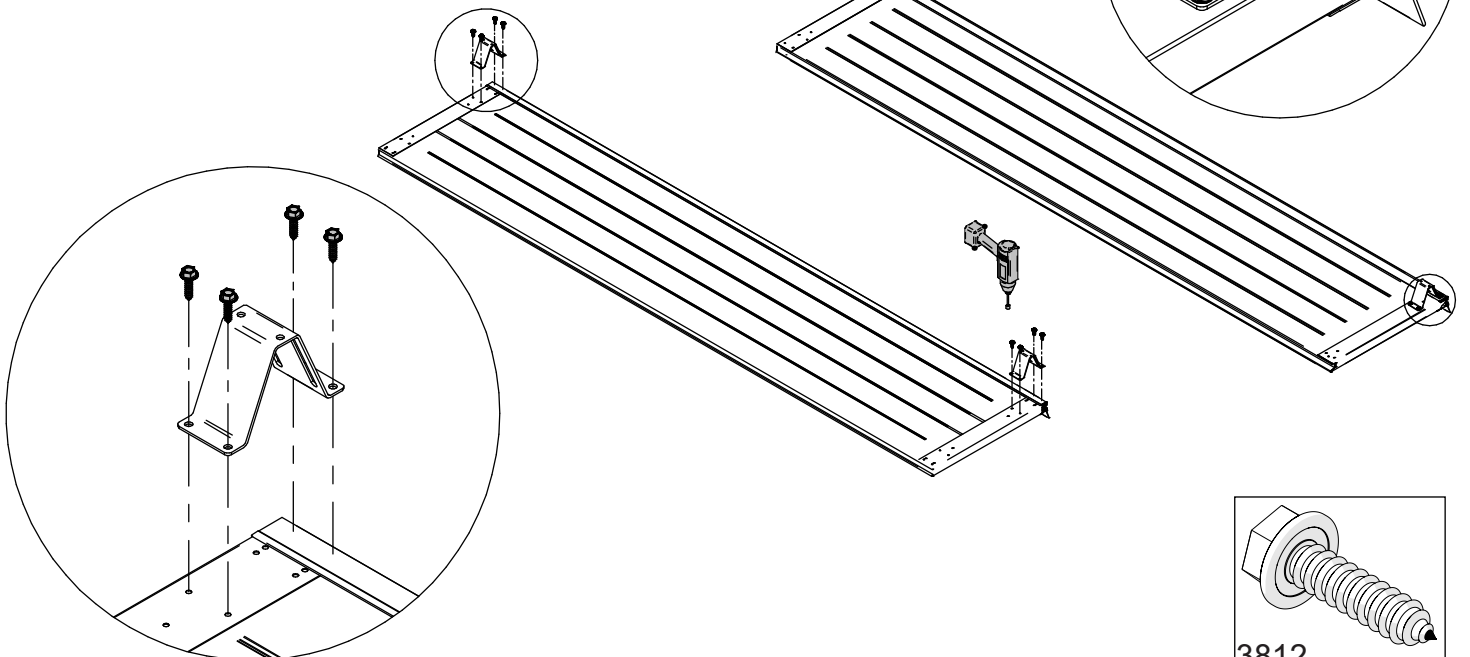
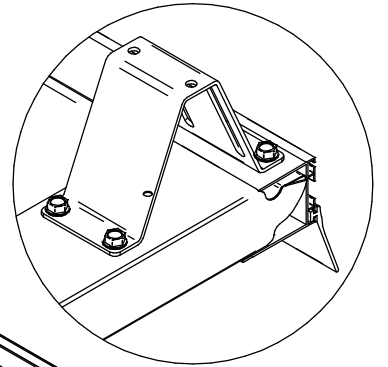
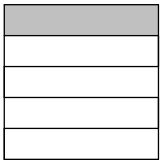
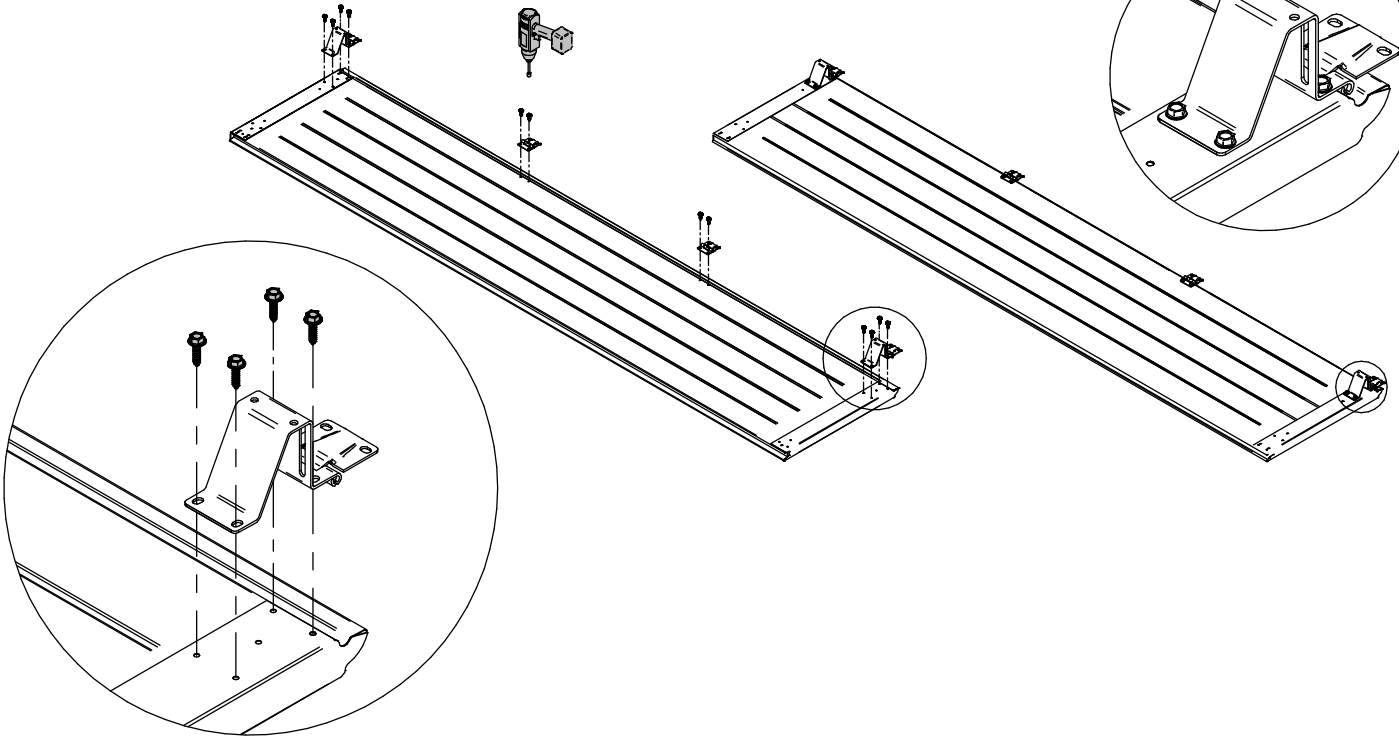
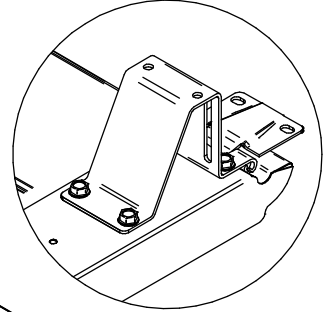
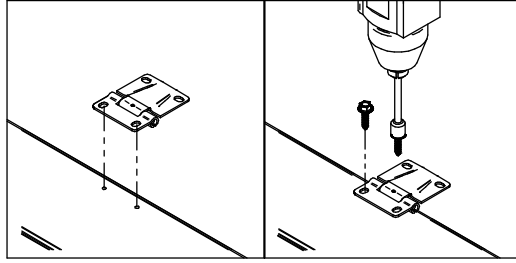
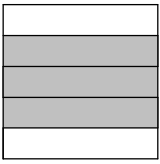

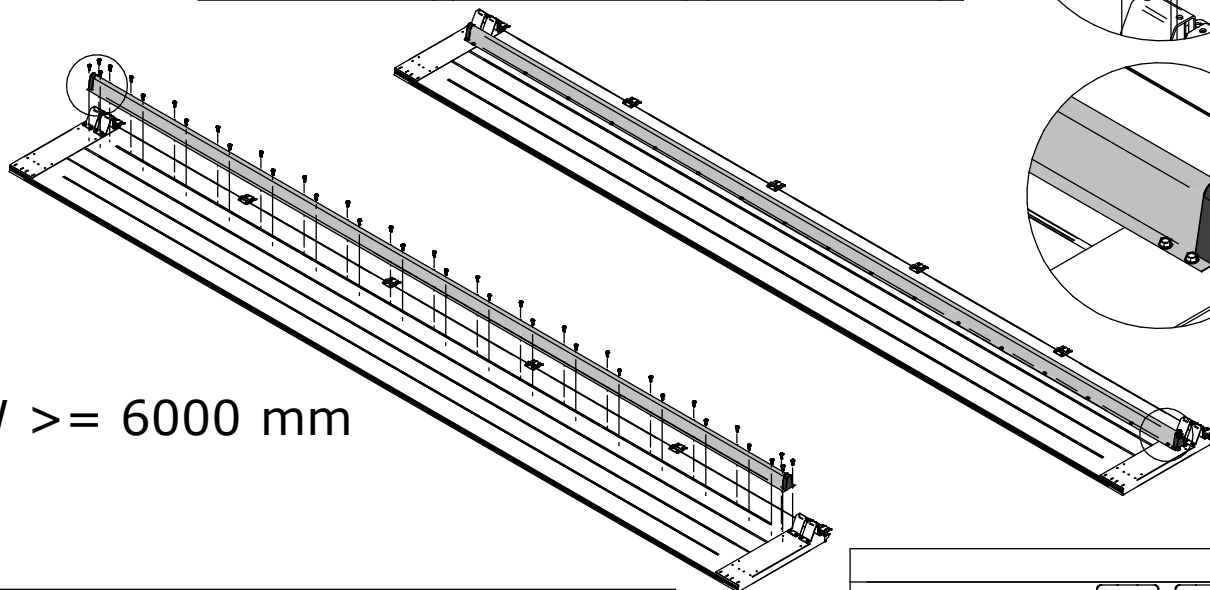
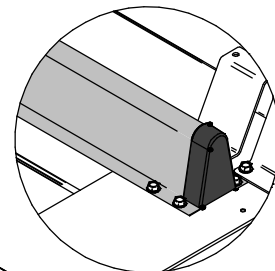
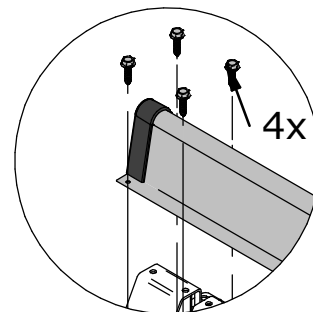
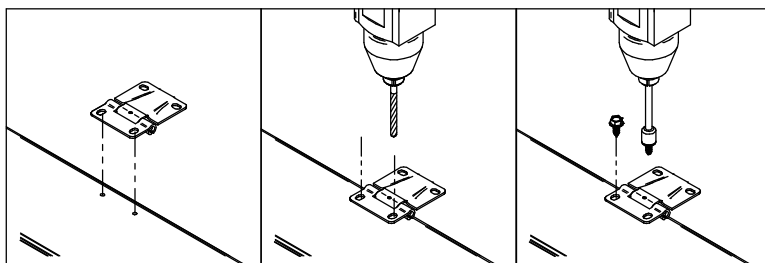
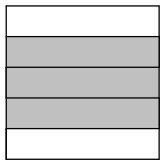

DLW \geq 6000 mm

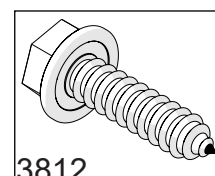
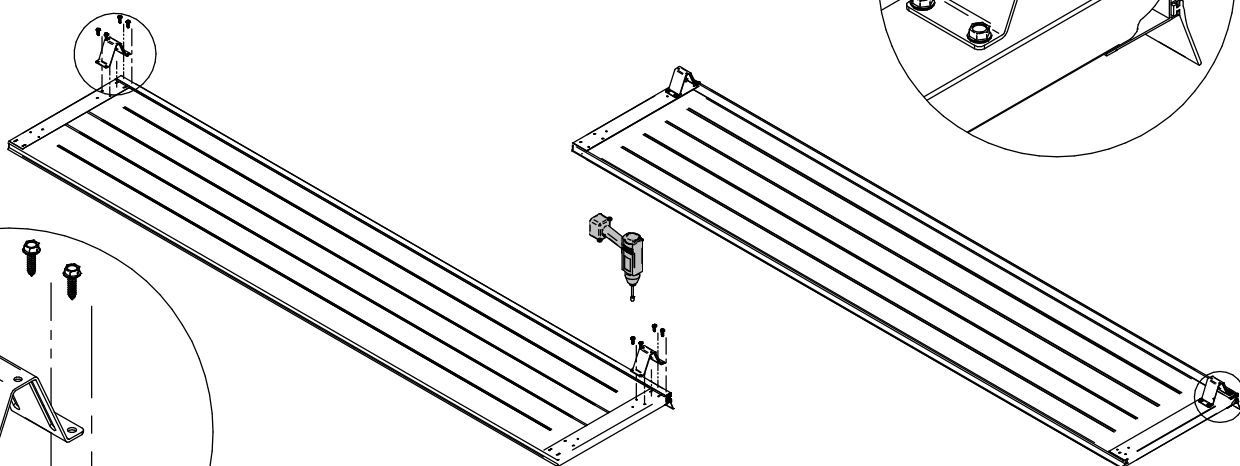
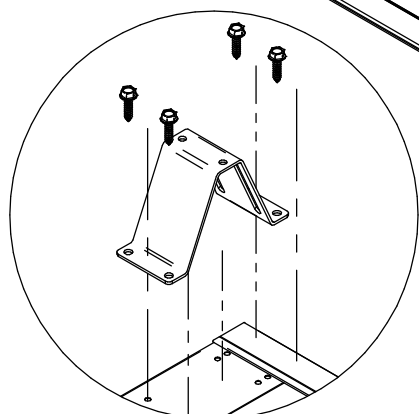
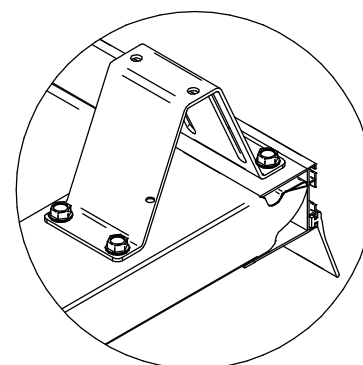
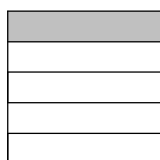
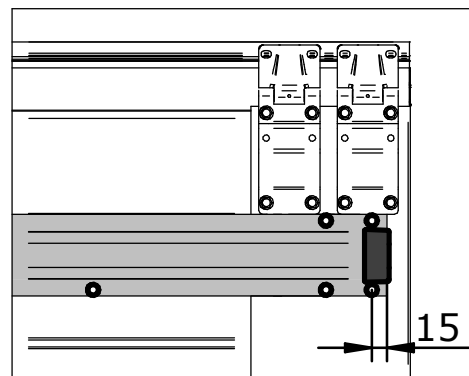
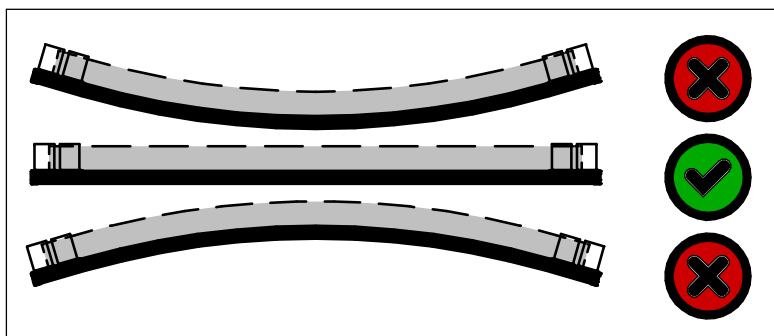

3812

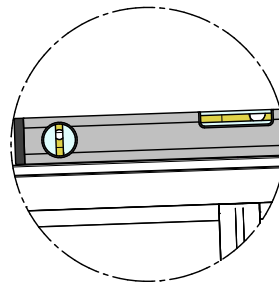
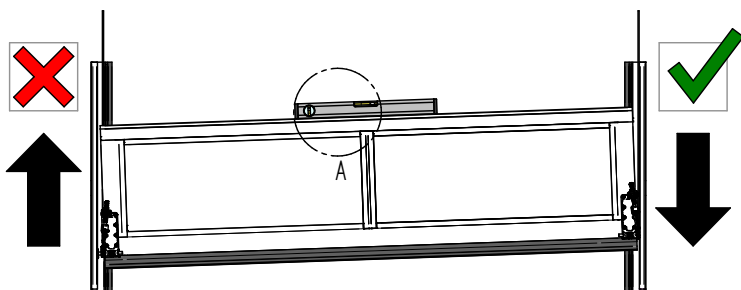
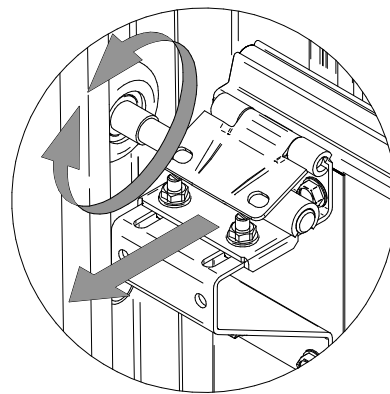
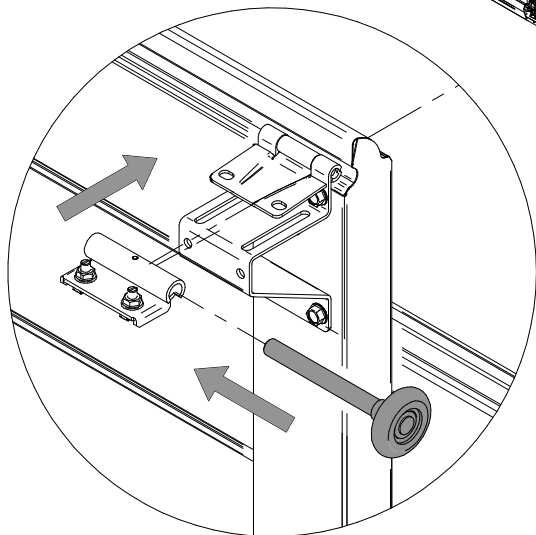
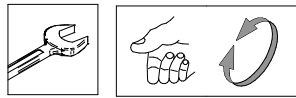
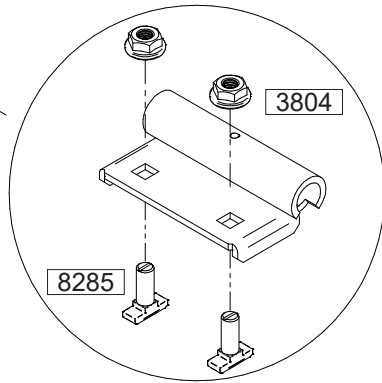
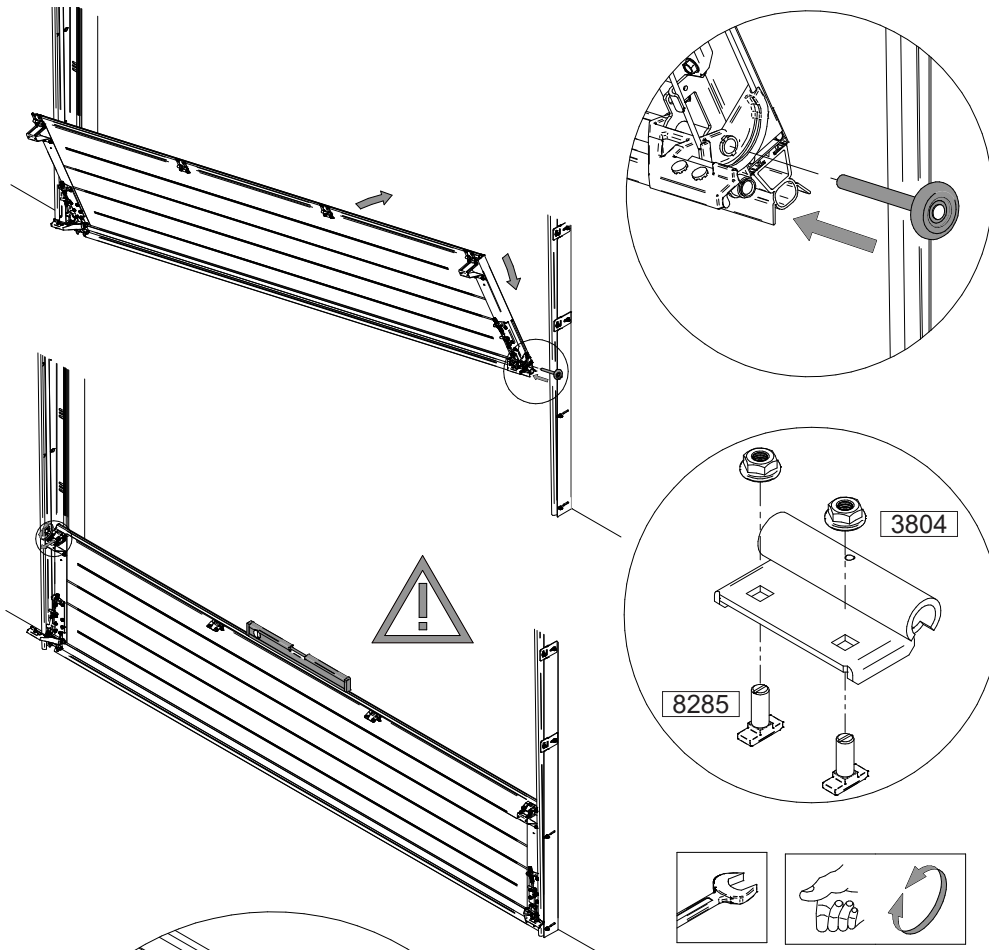

DETAIL A

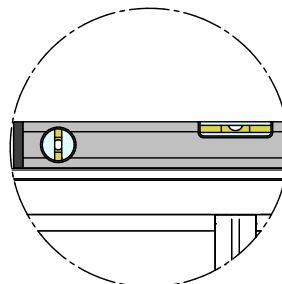
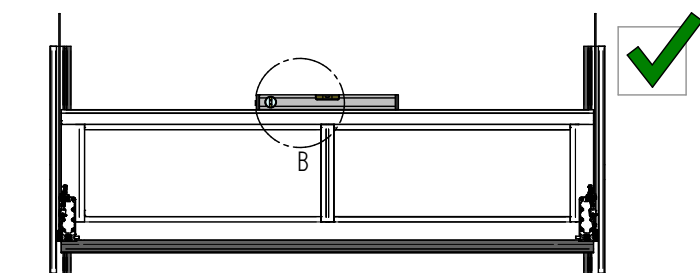

DETAIL B

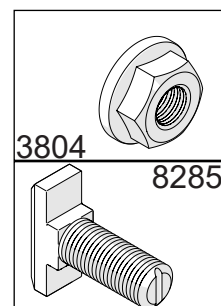

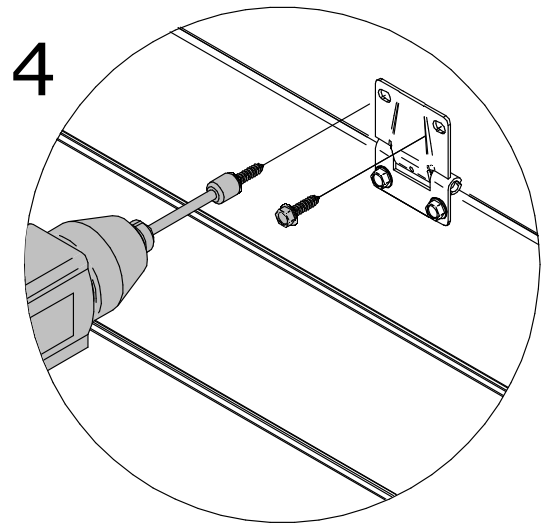
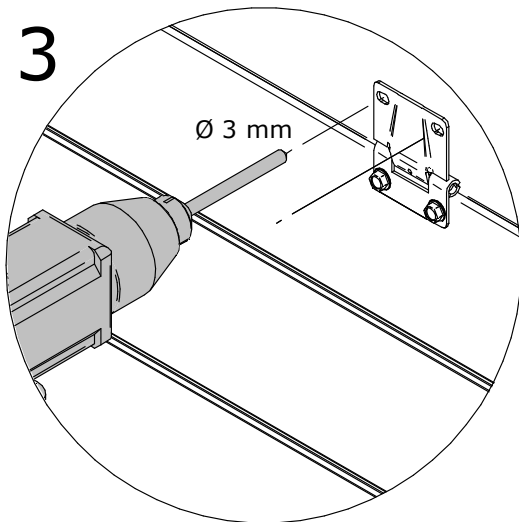
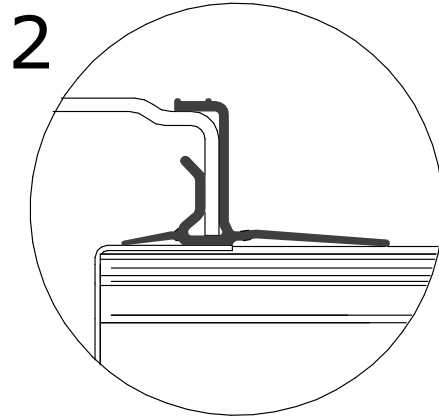
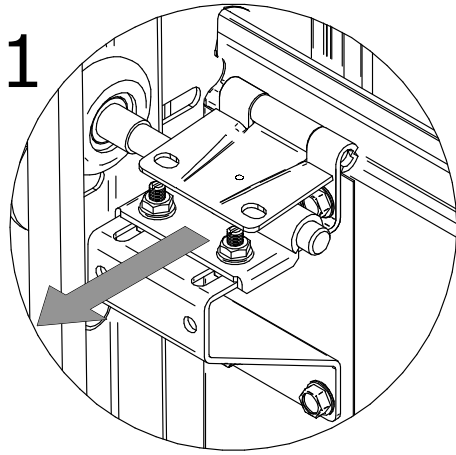
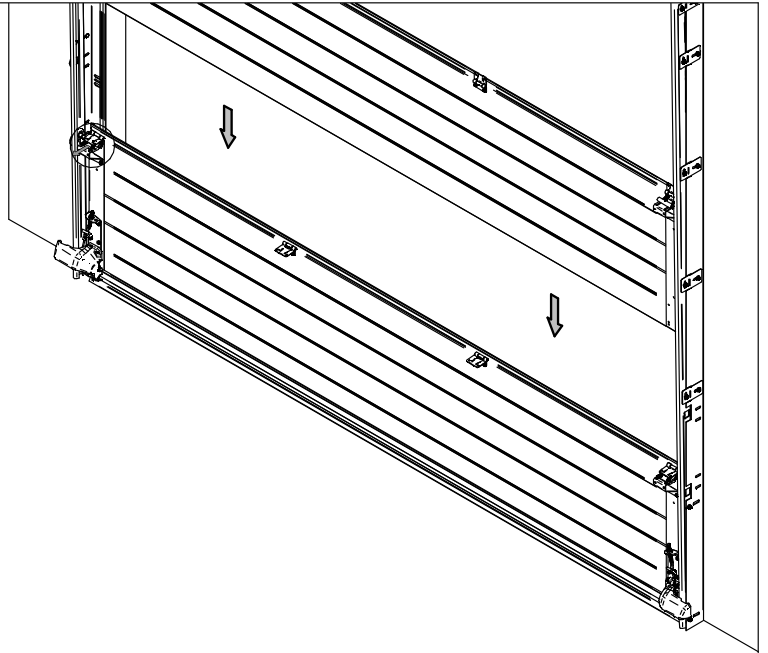
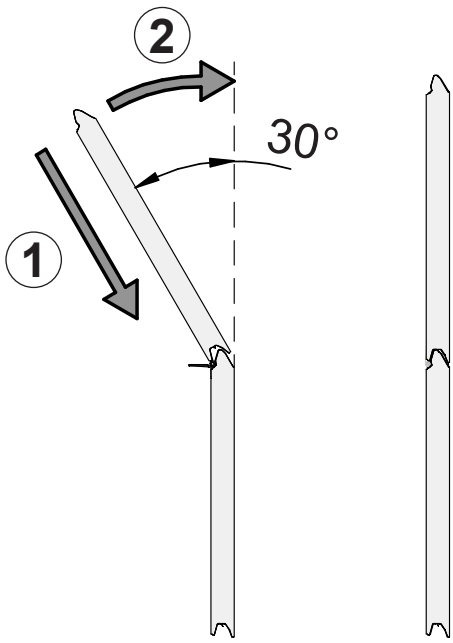

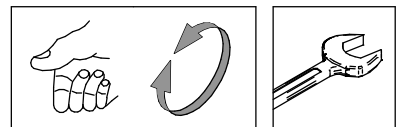
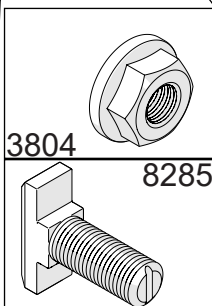
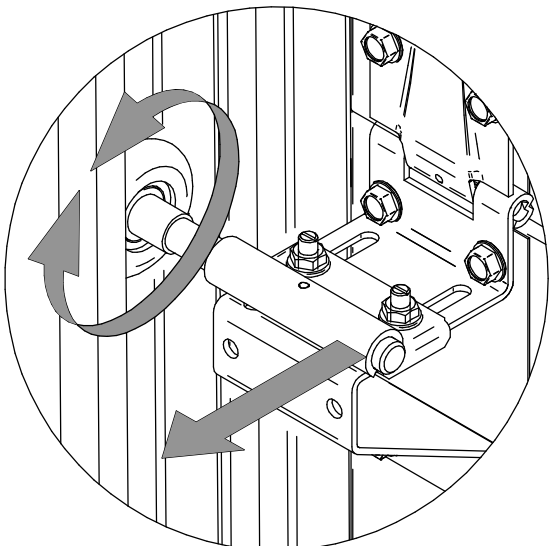
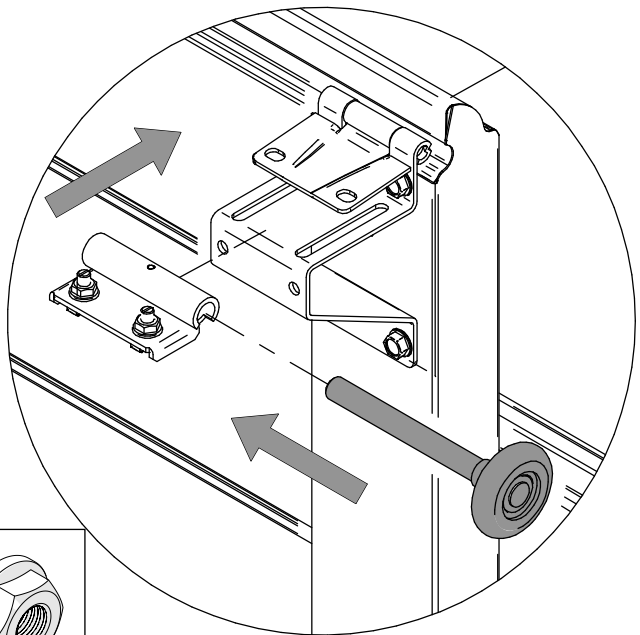
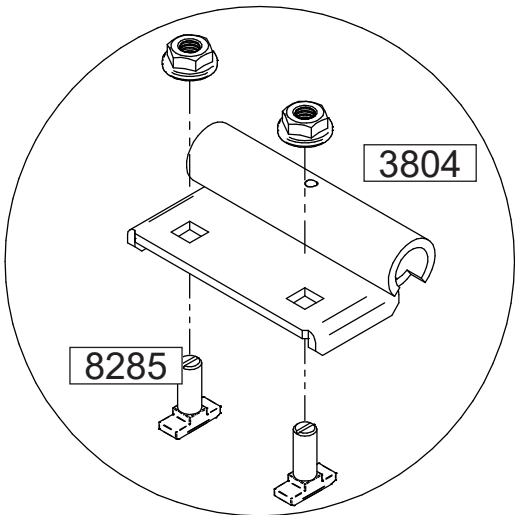
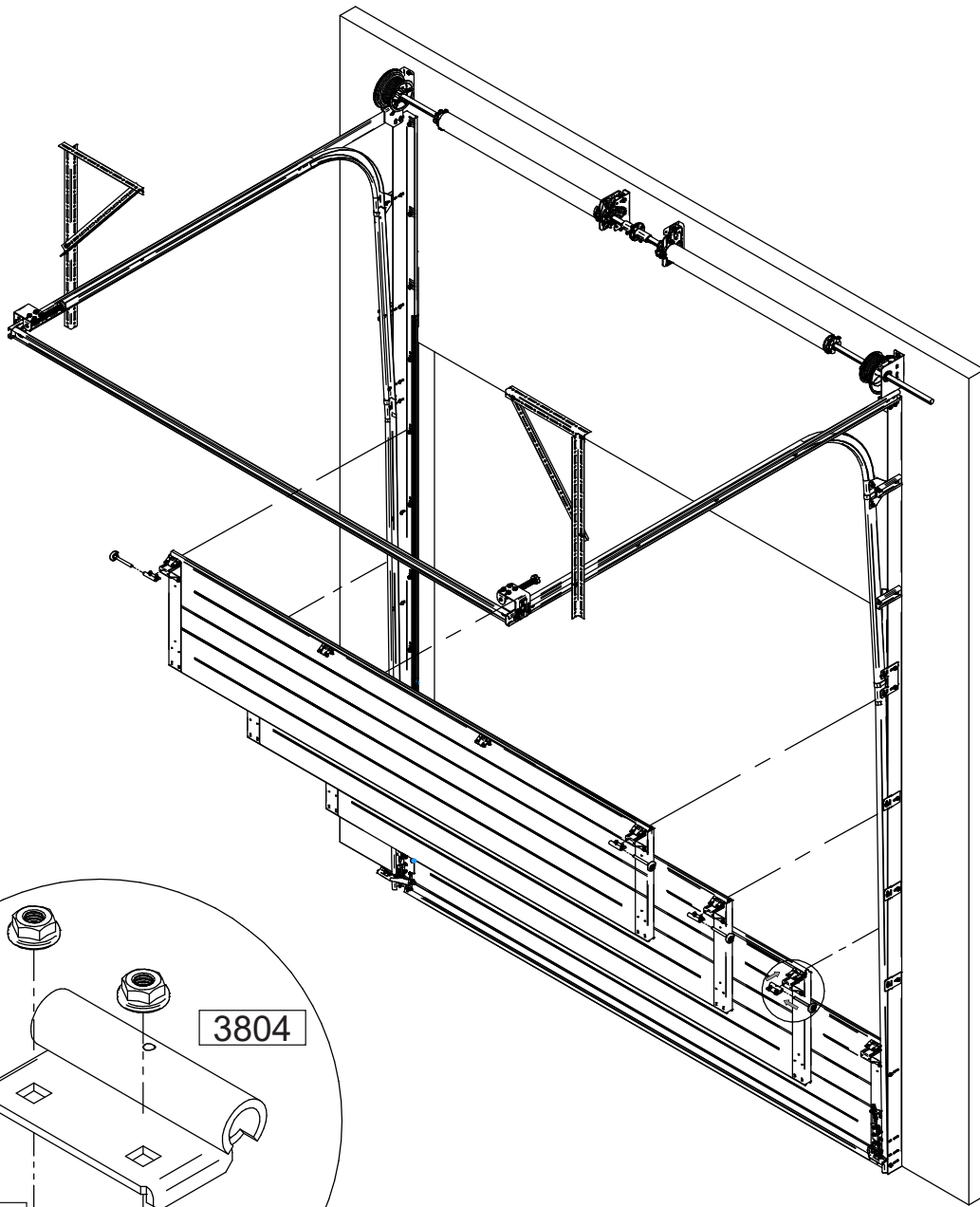

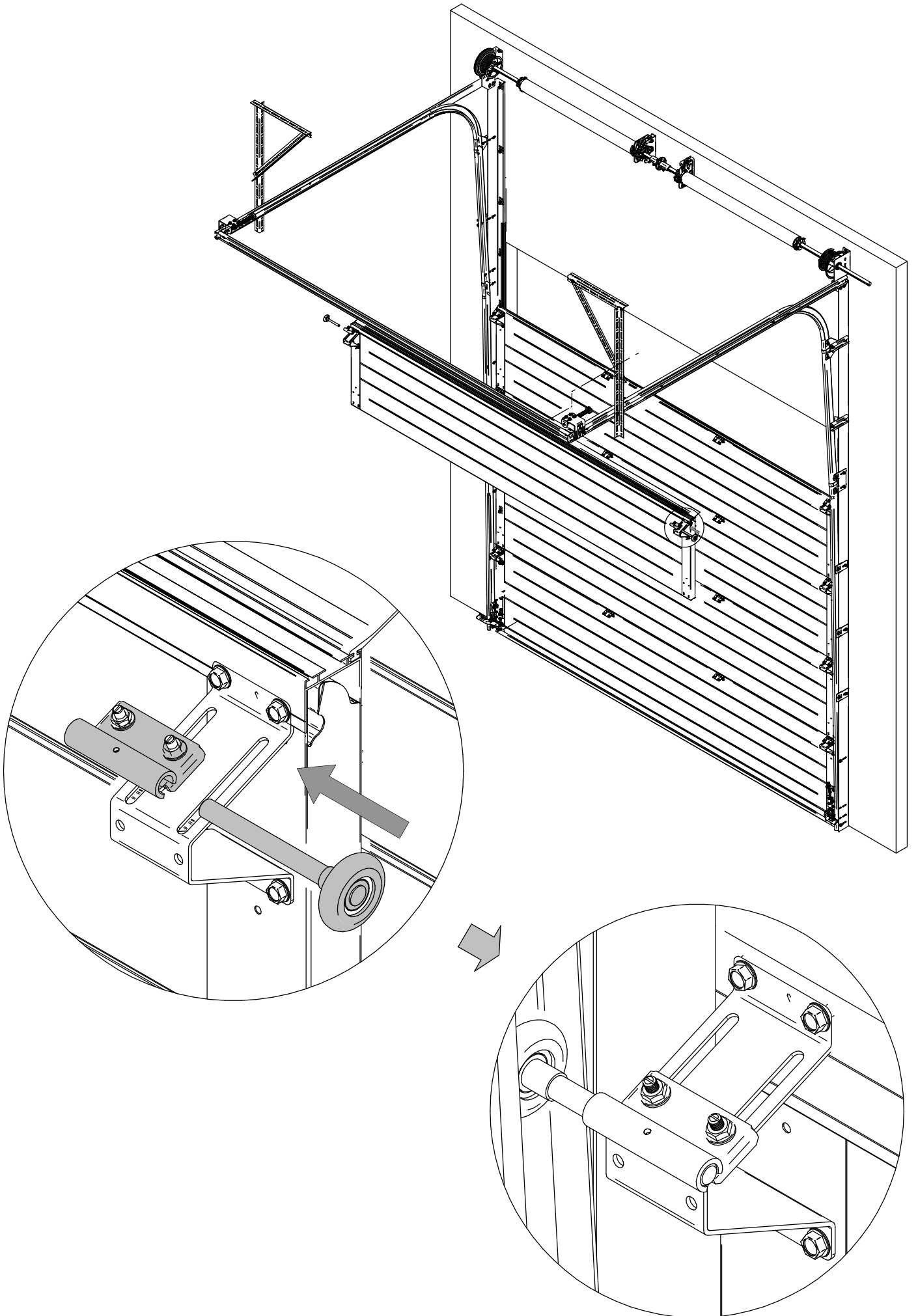

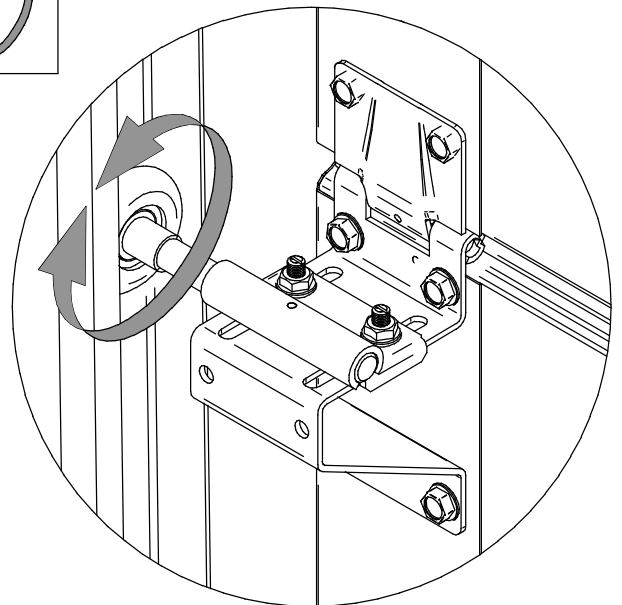
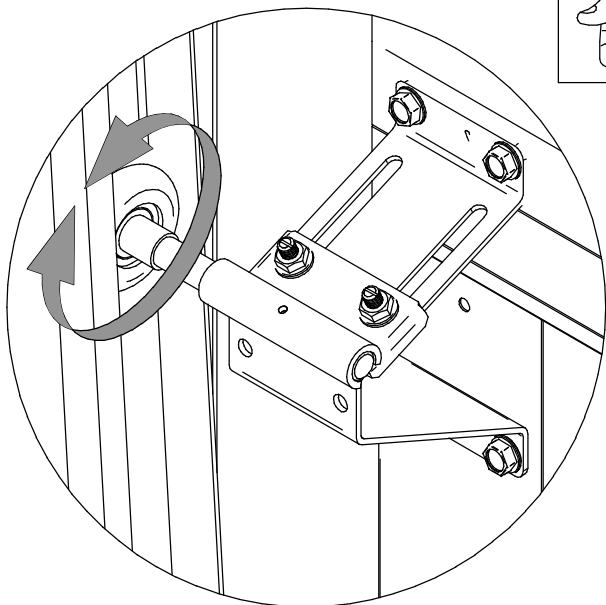
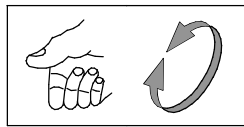
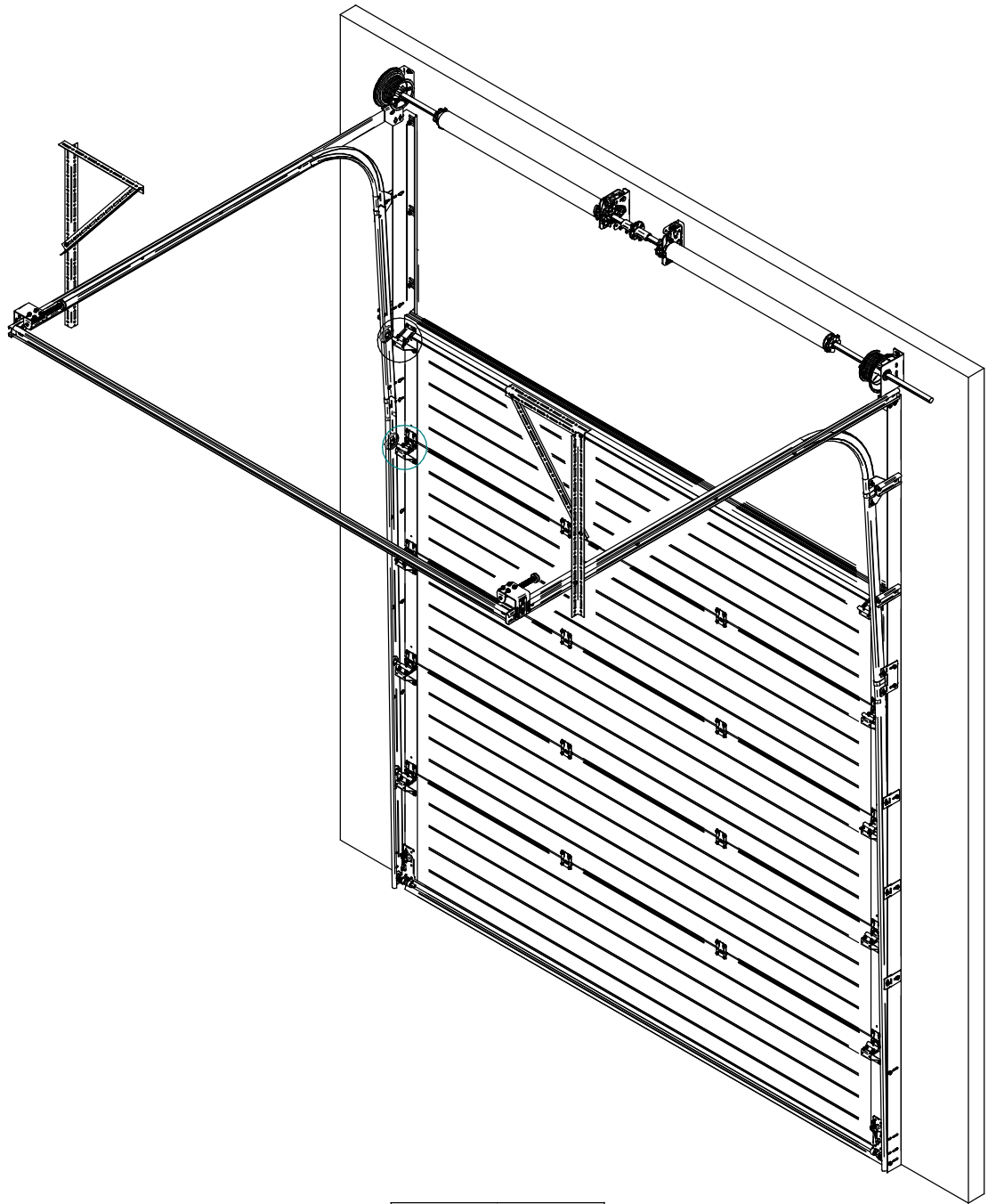

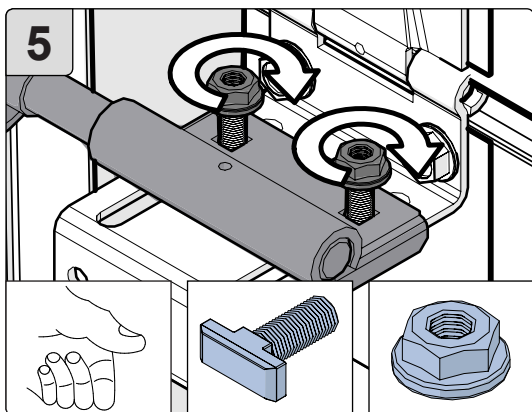
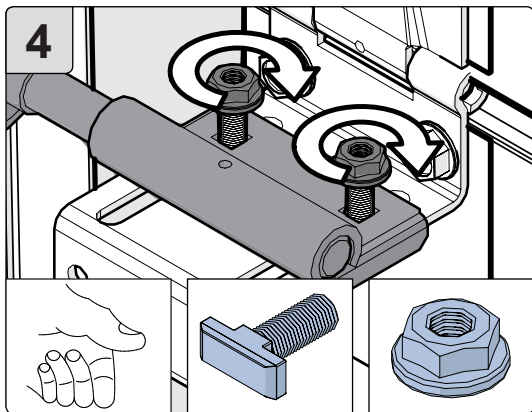
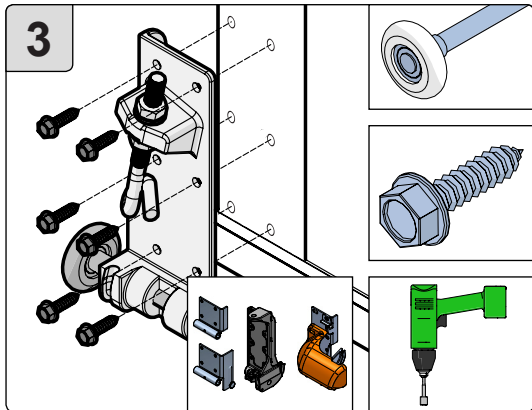
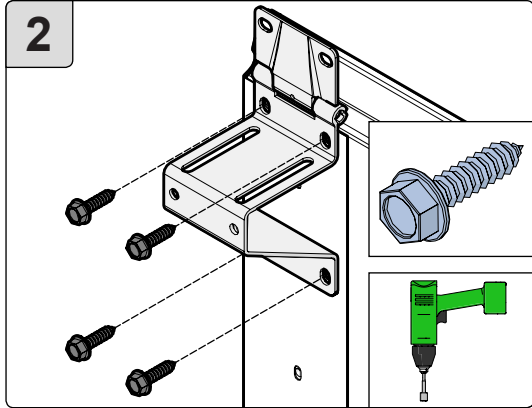
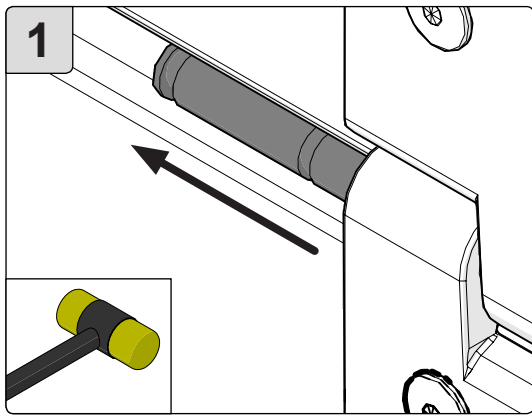

OPTION

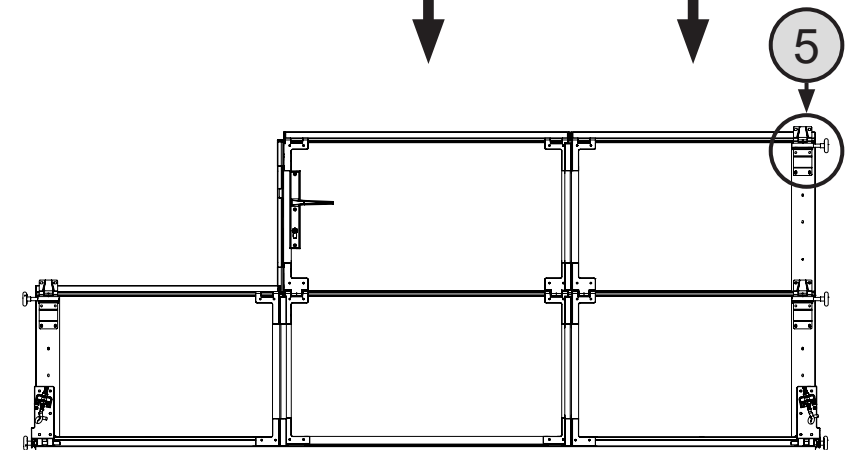
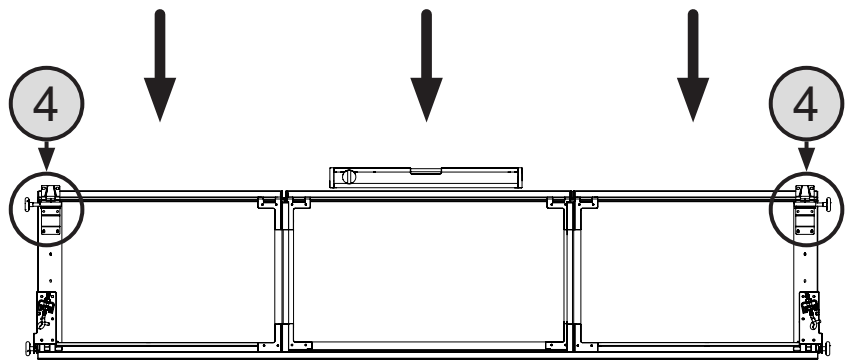
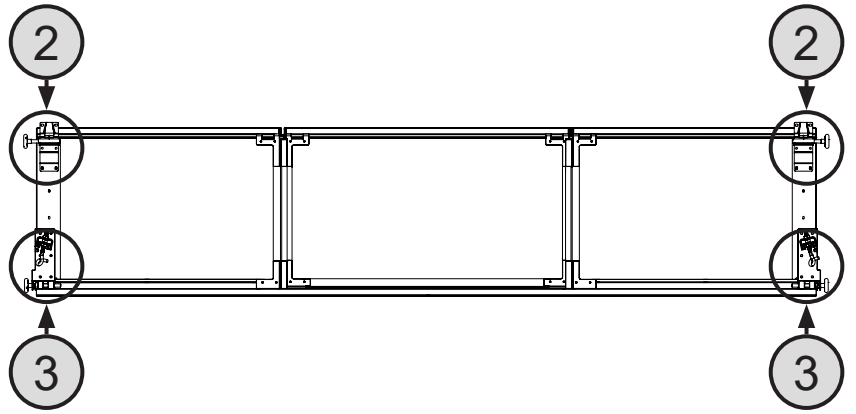

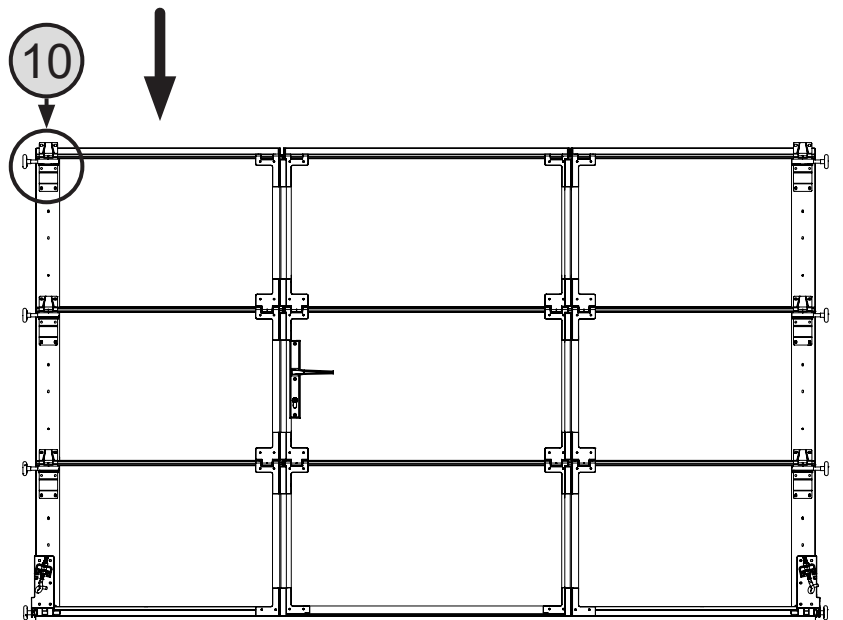
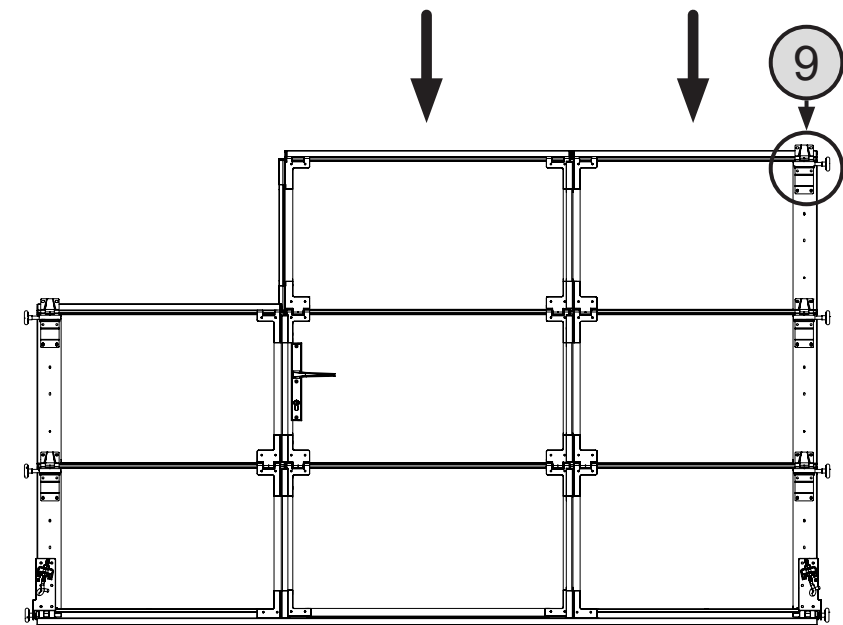
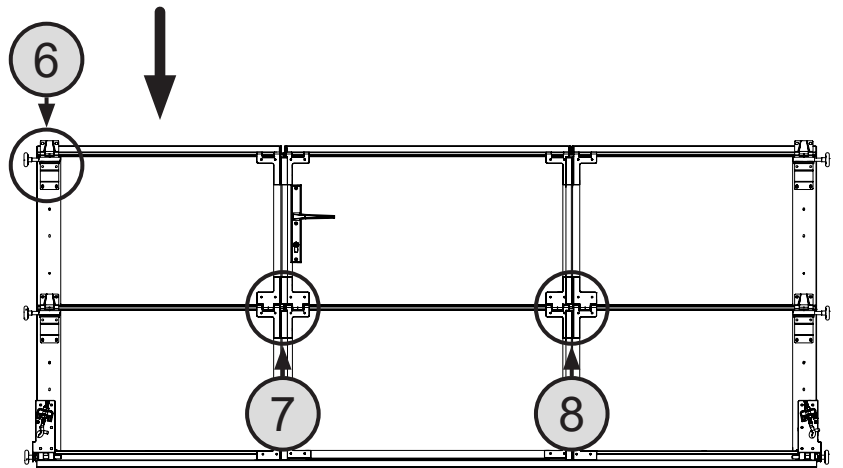
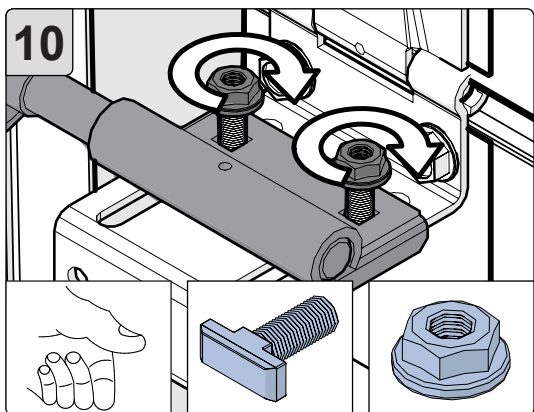
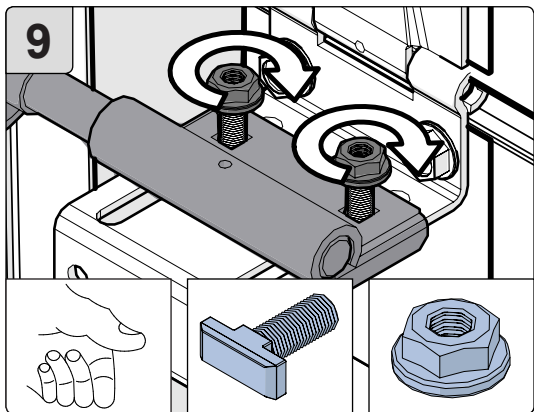
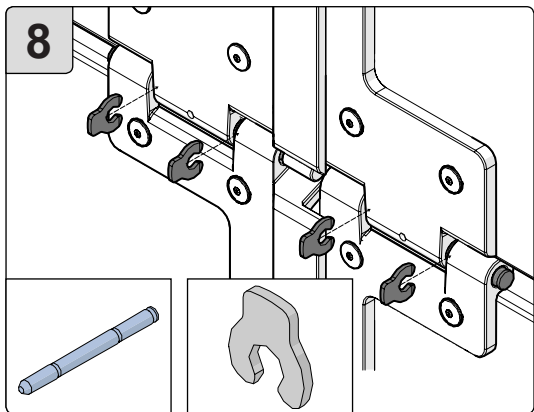
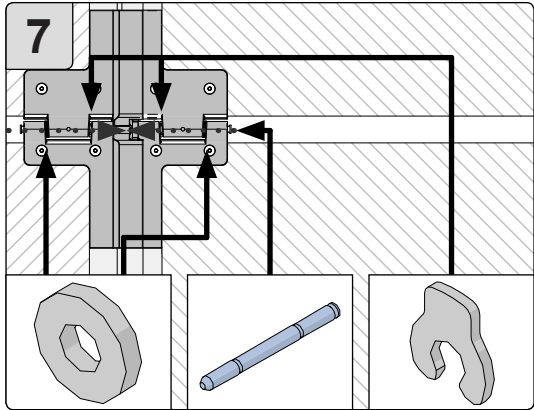
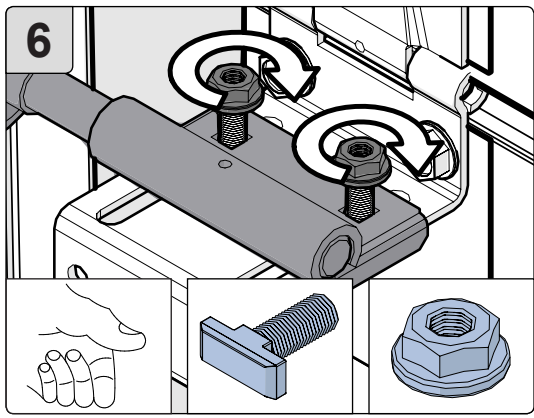

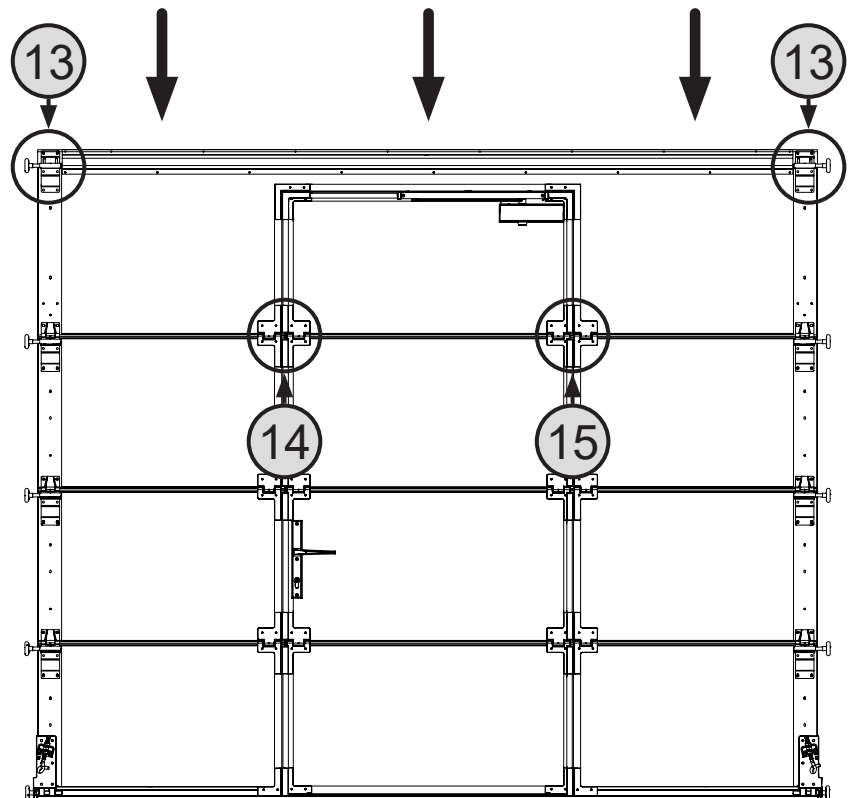
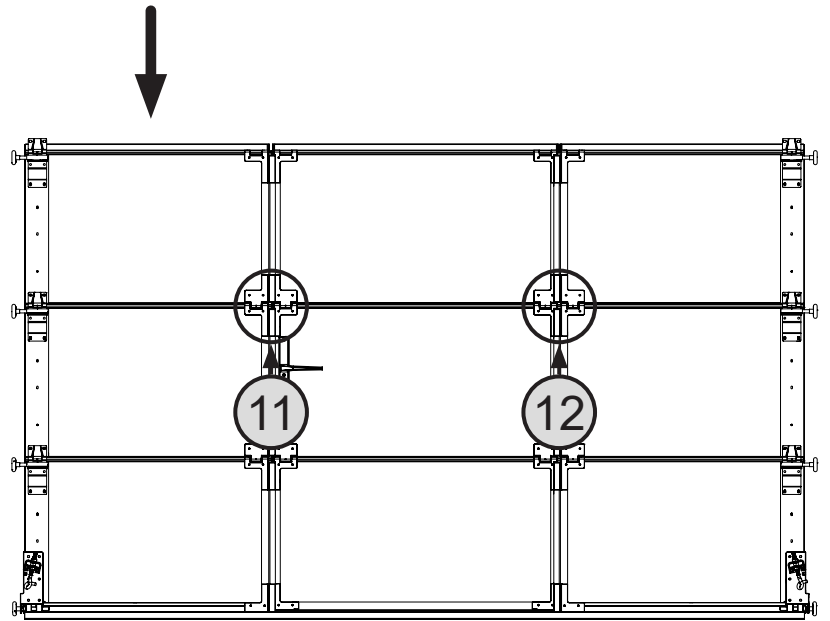
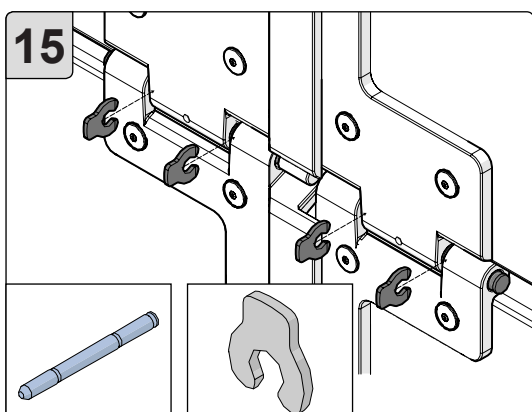
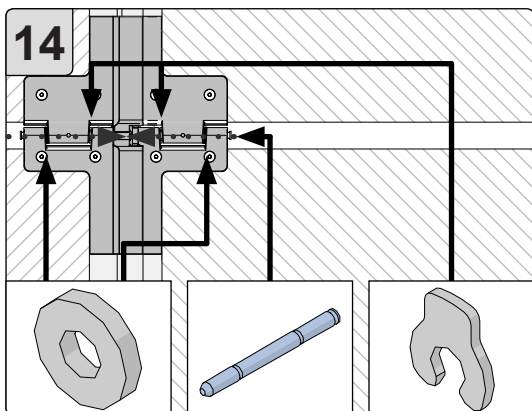
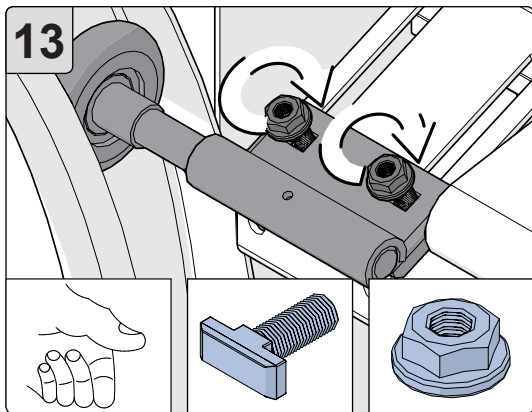
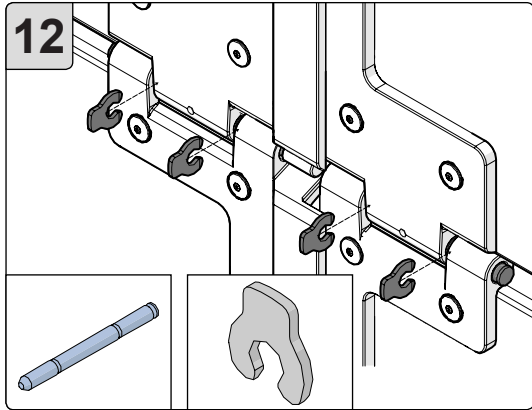
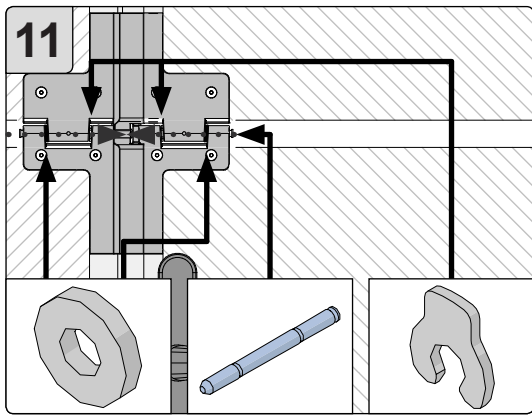

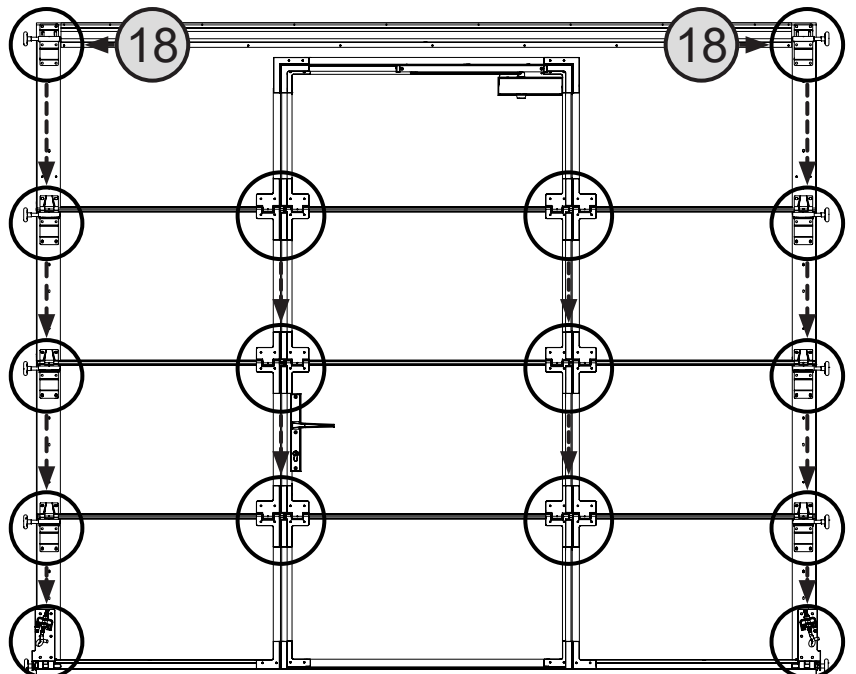
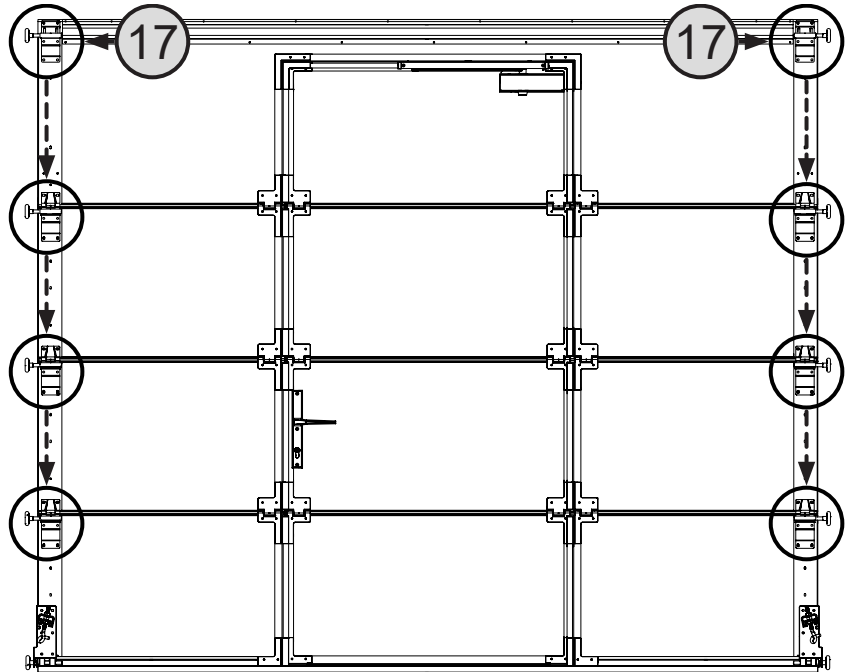
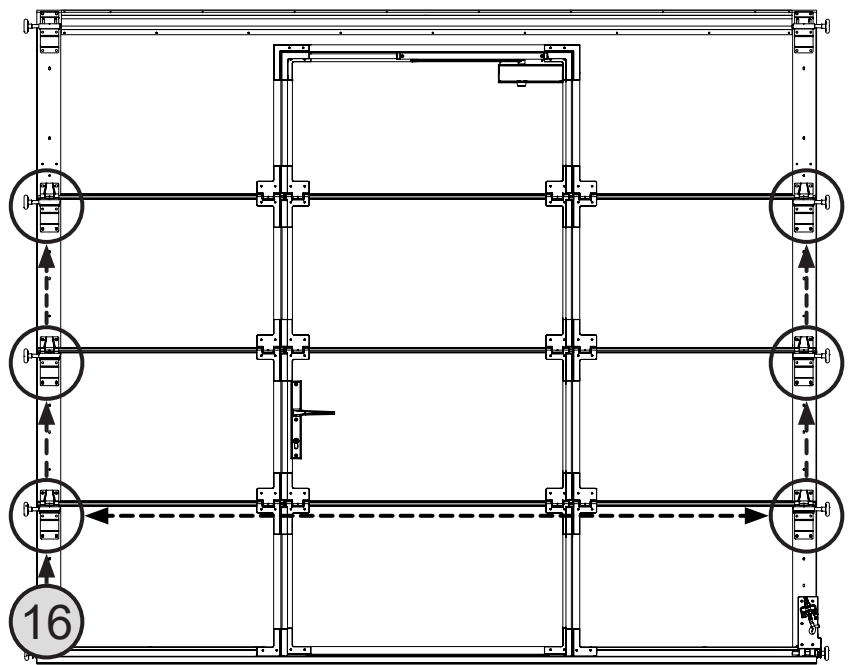
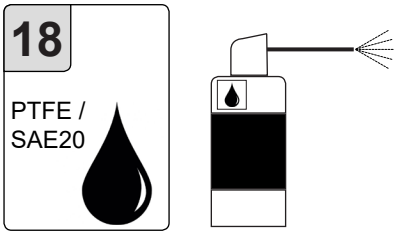
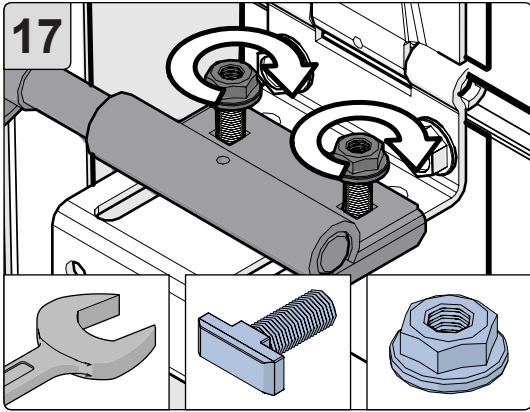
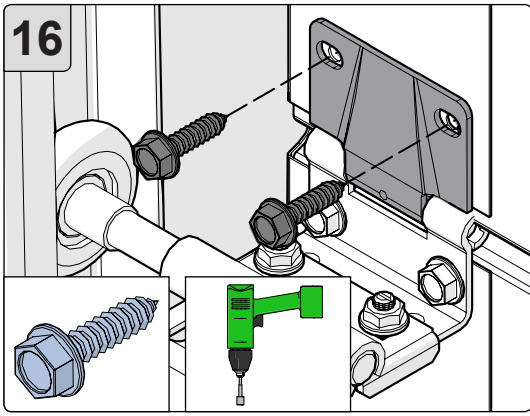

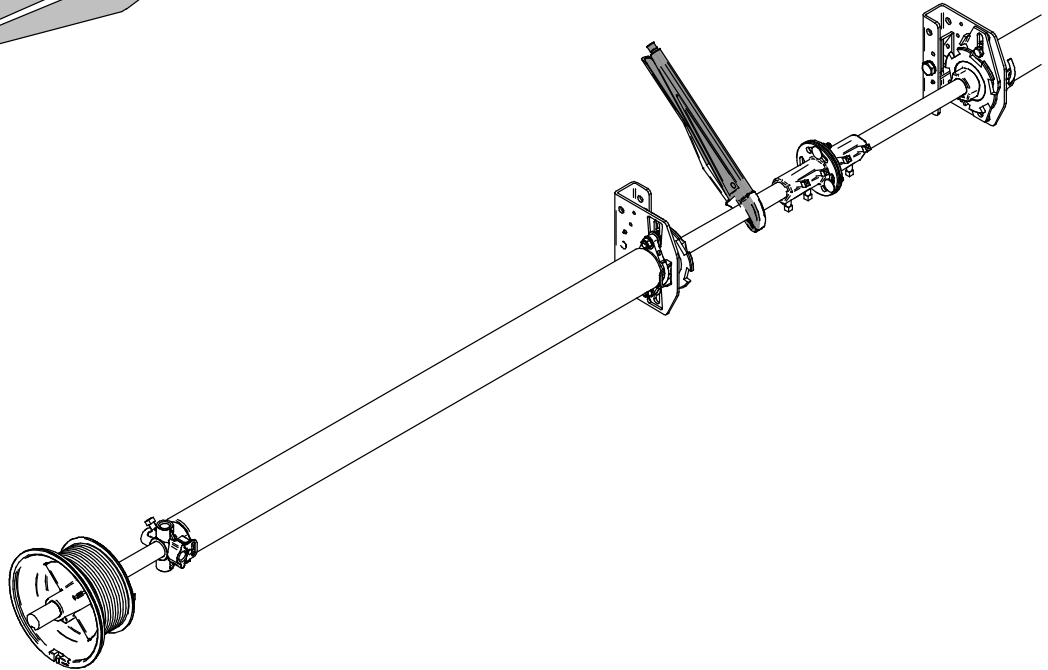
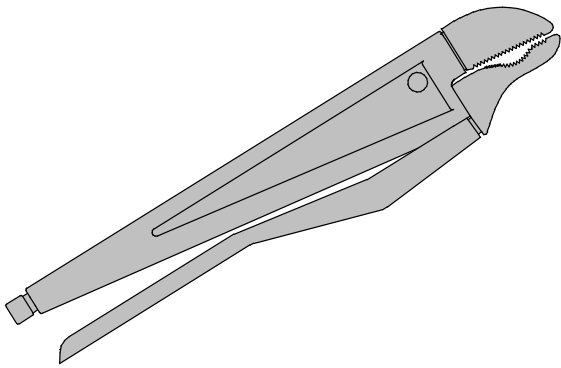
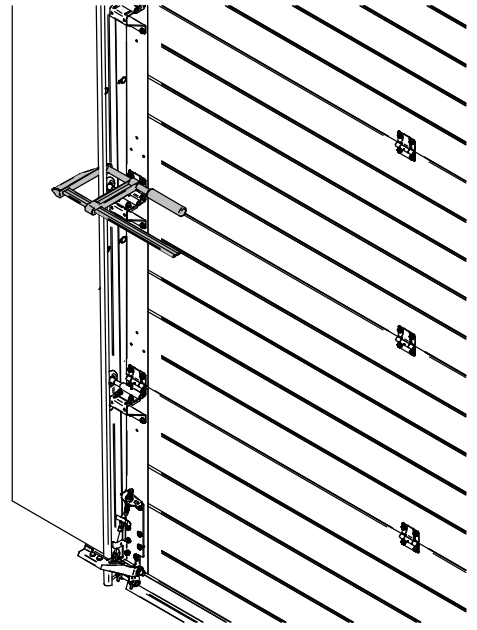
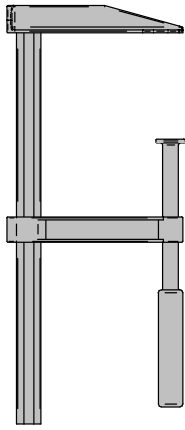

1

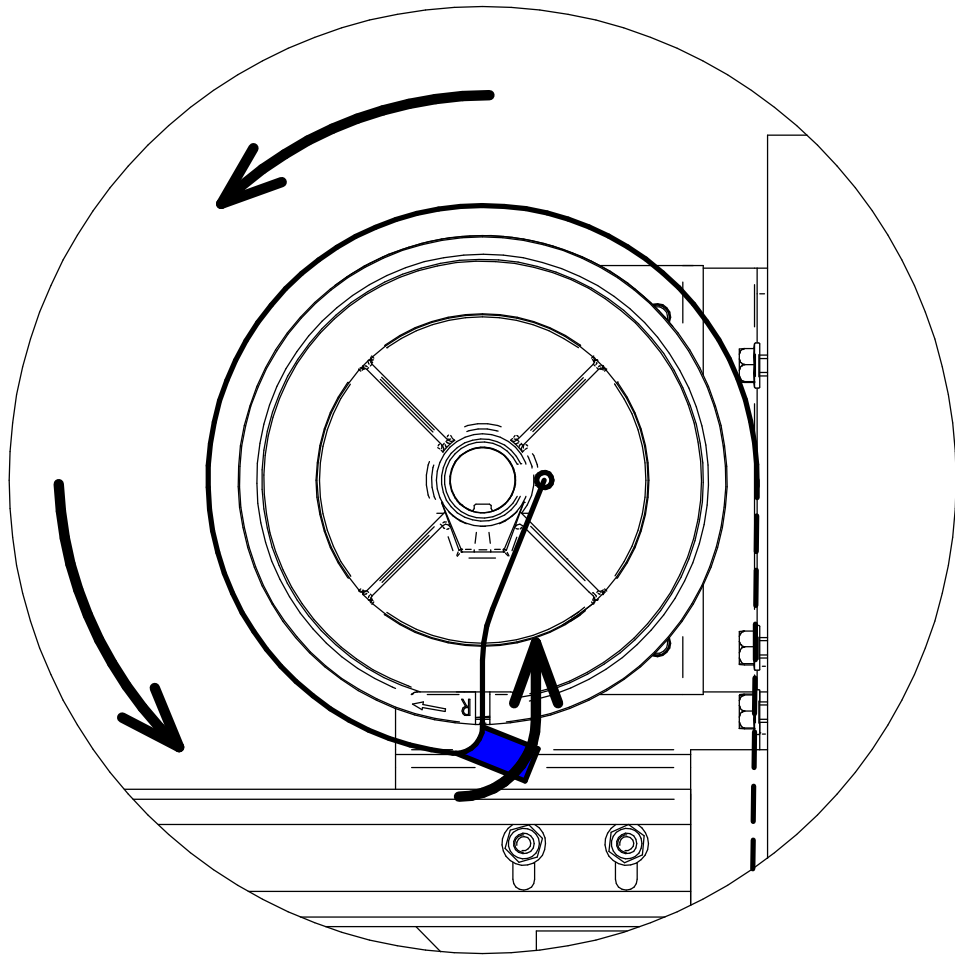
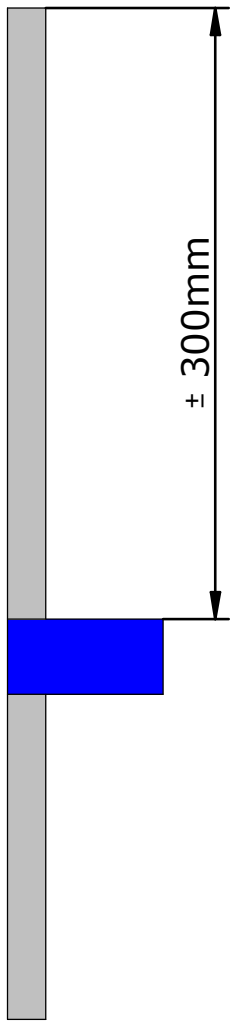

2

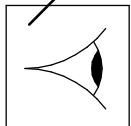
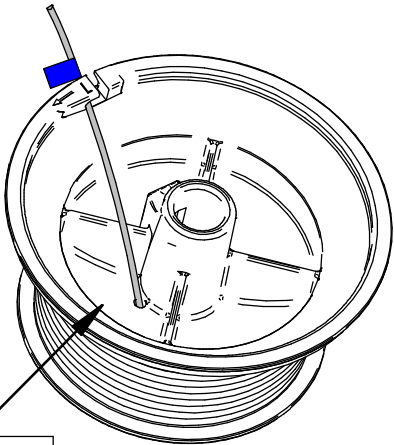

3

- $\frac{1}{2}$ x Veiligheidswinding
- $\frac{1}{2}$ x Sicherheitswicklung
- $\frac{1}{2}$ x Safety wind
- $\frac{1}{2}$ x Tour de sécurité

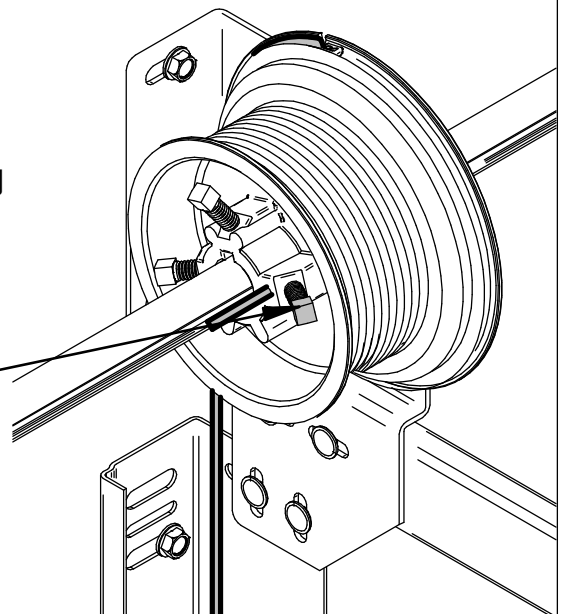
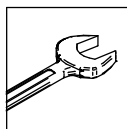

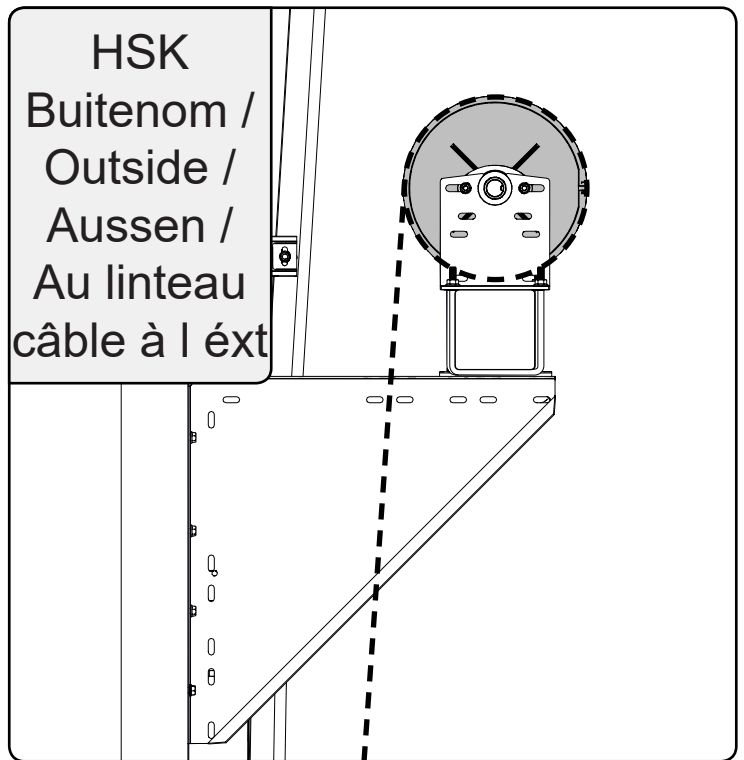
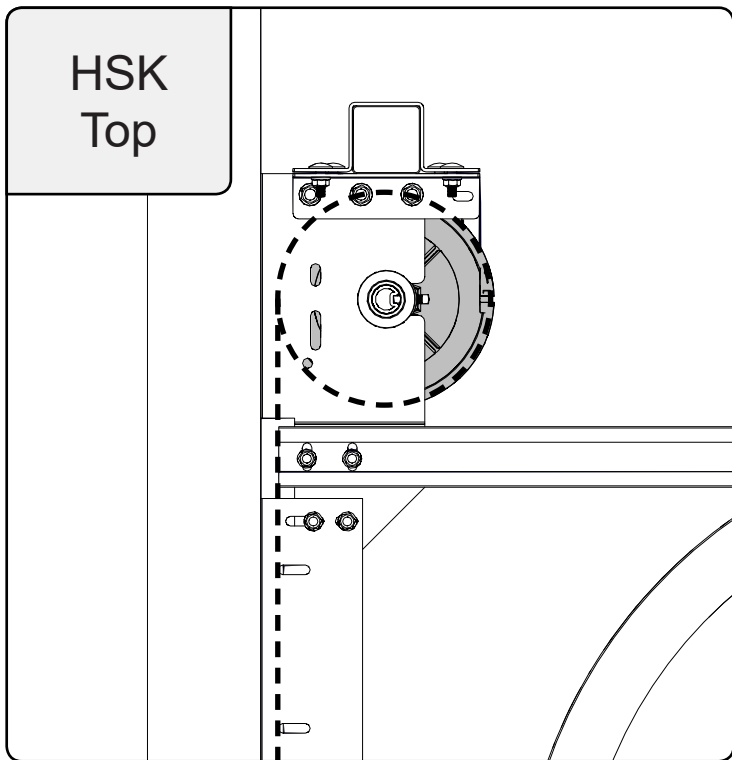
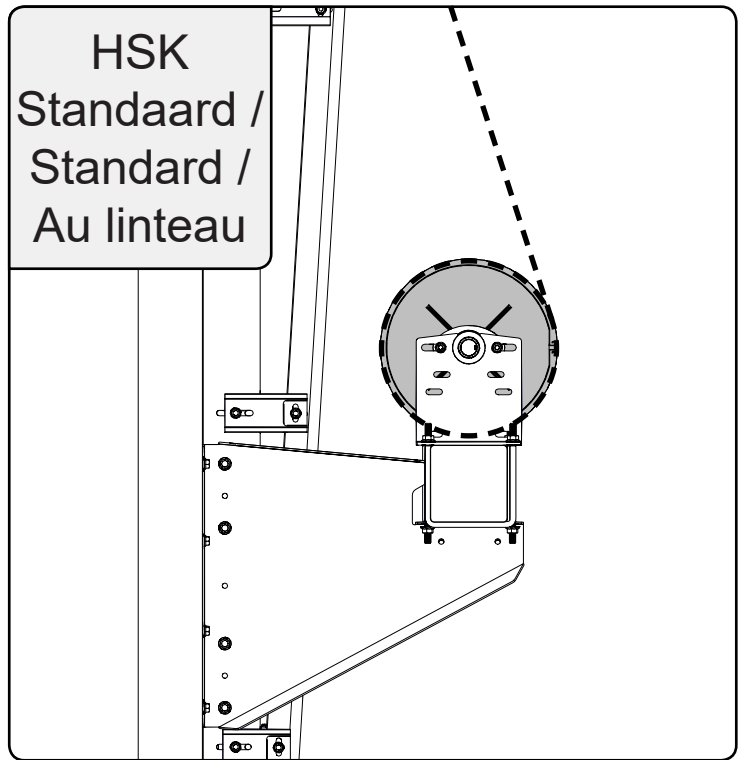
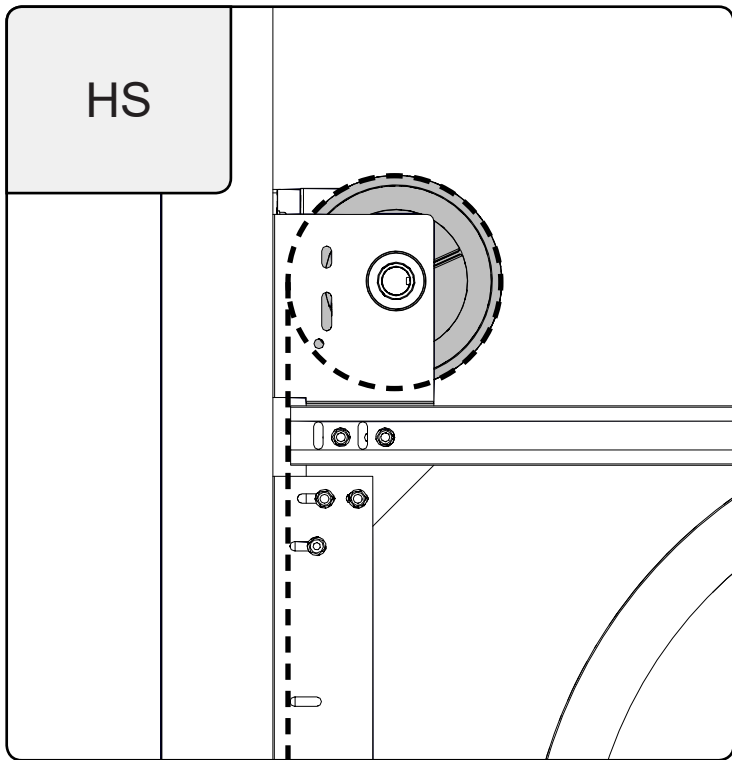

Option / Optie

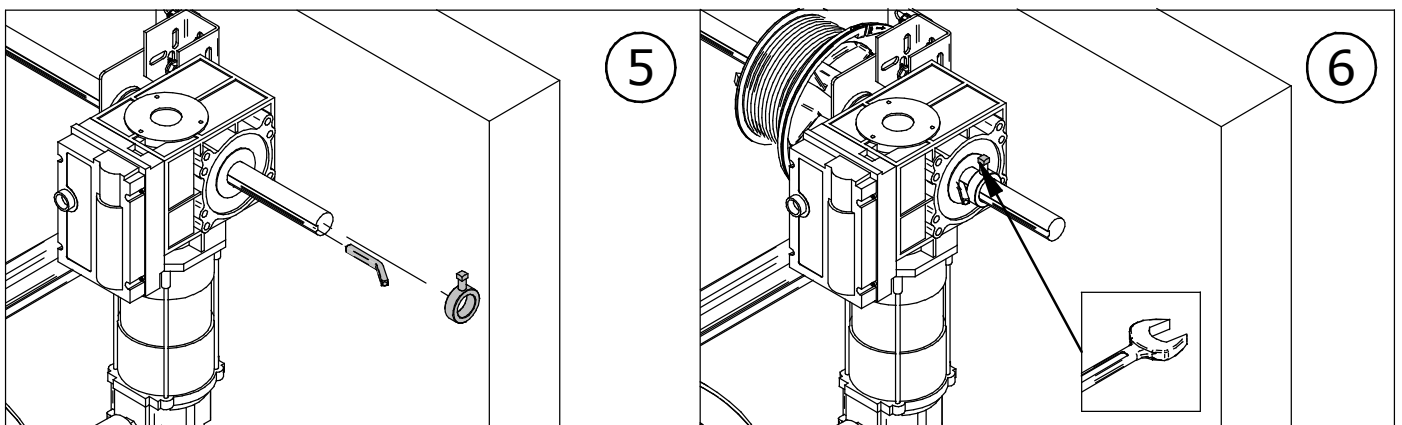
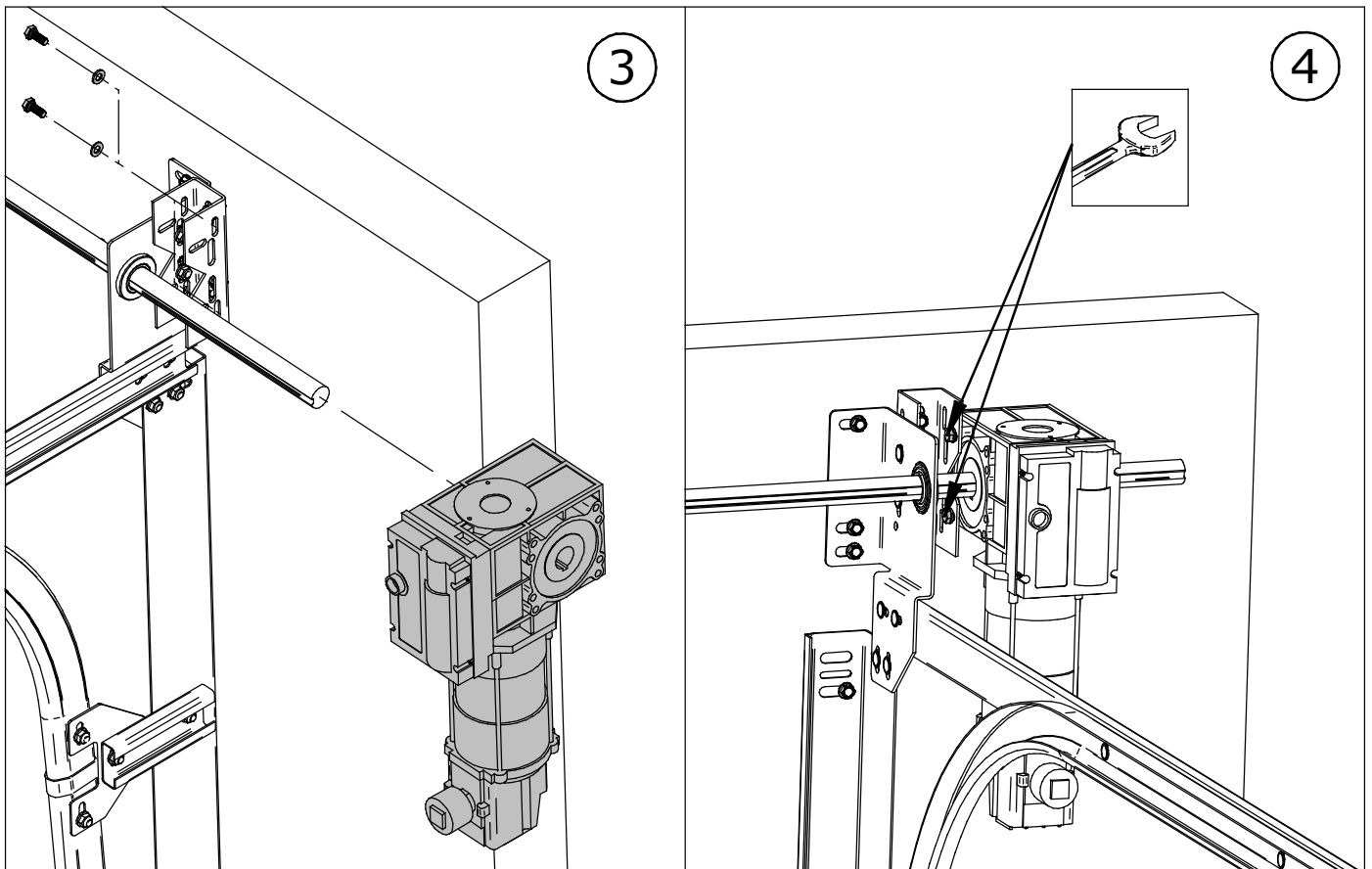
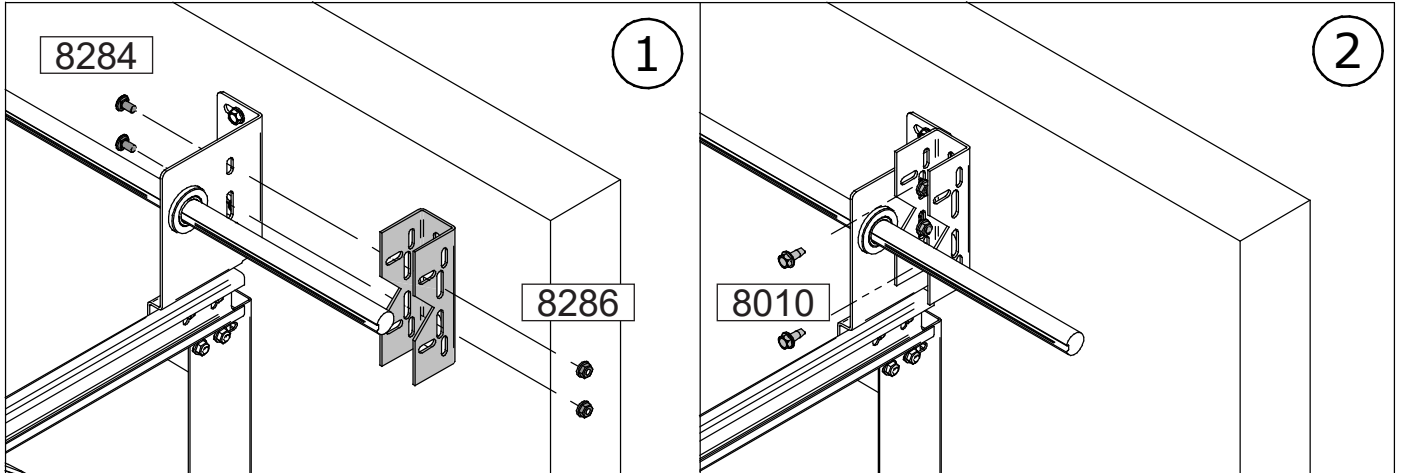

Option / Optie

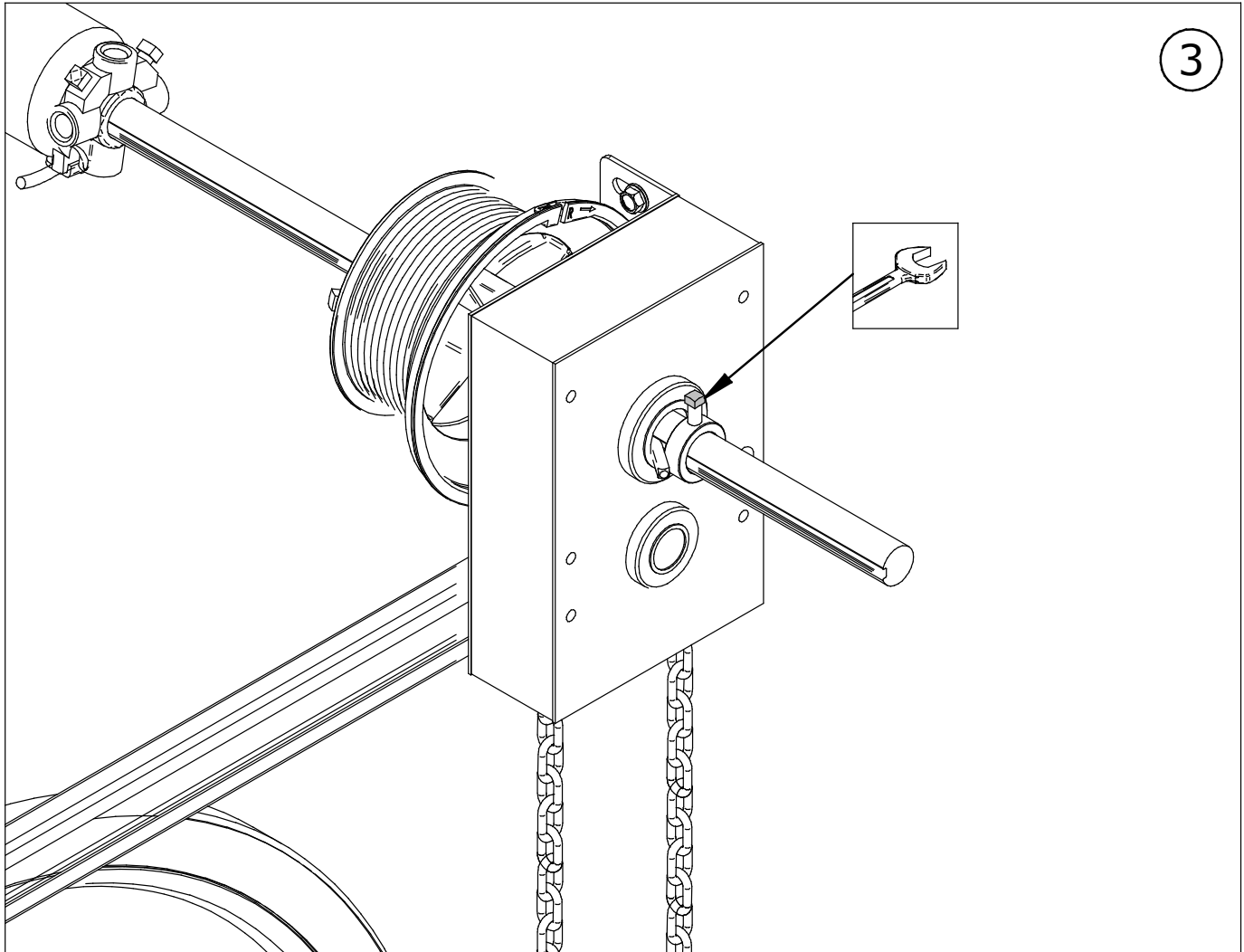
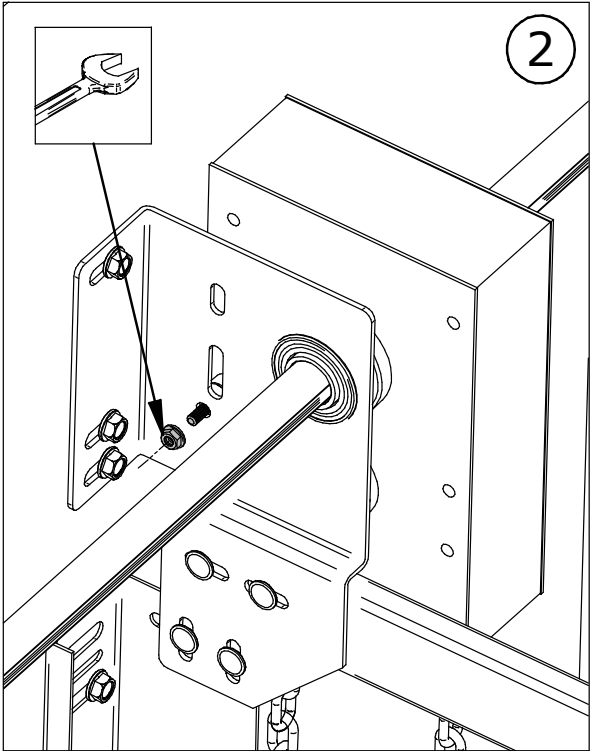
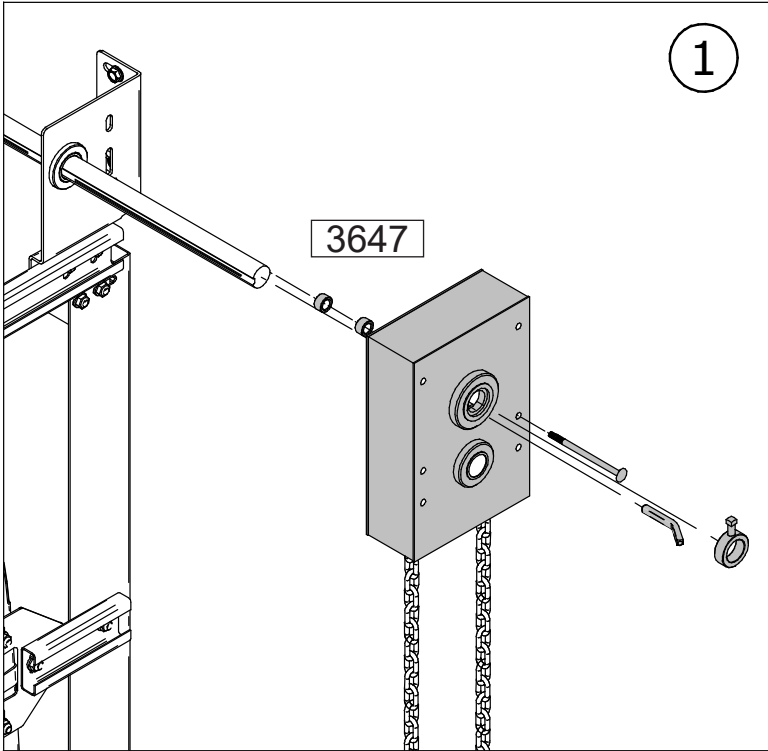

Option / Optie

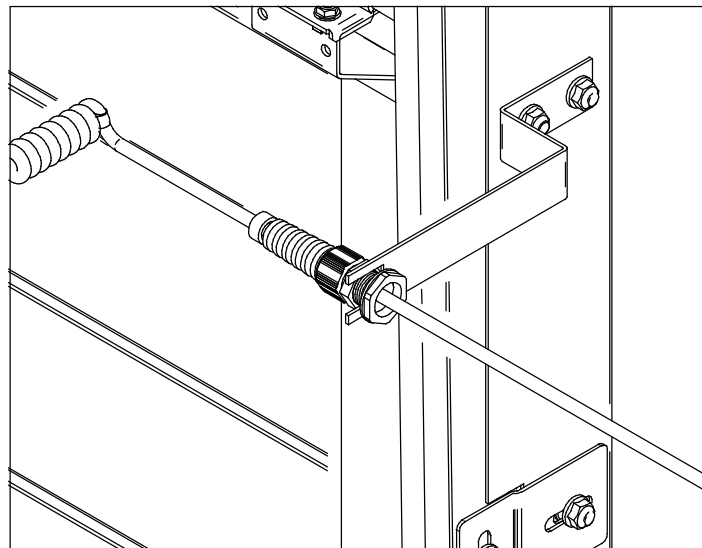
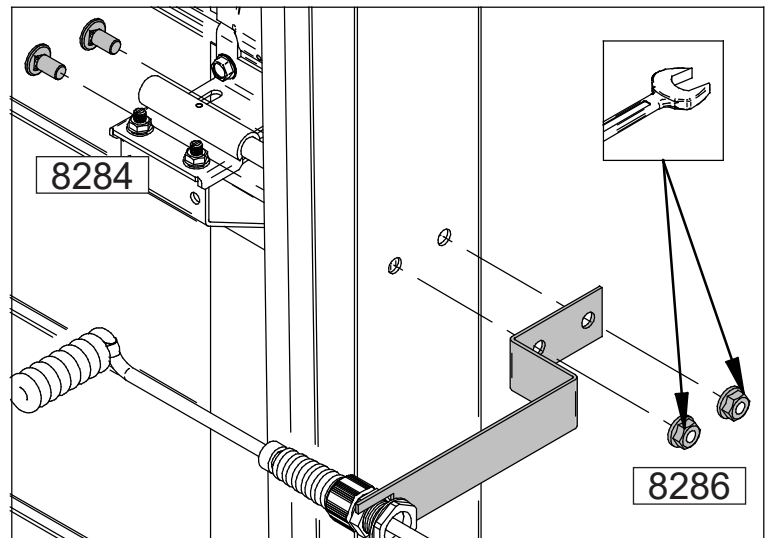
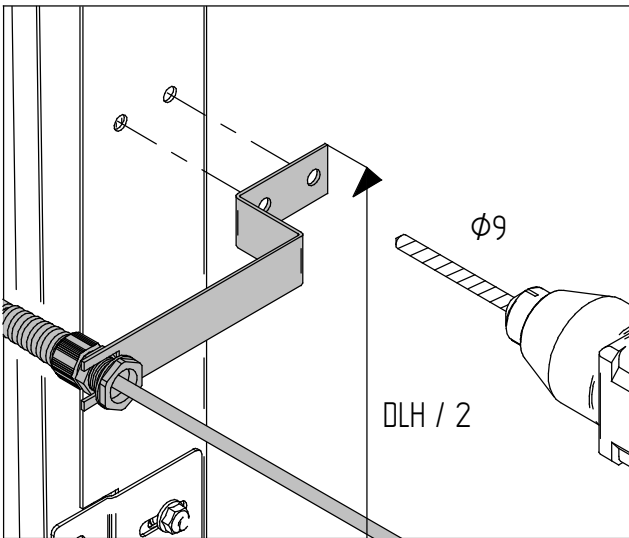
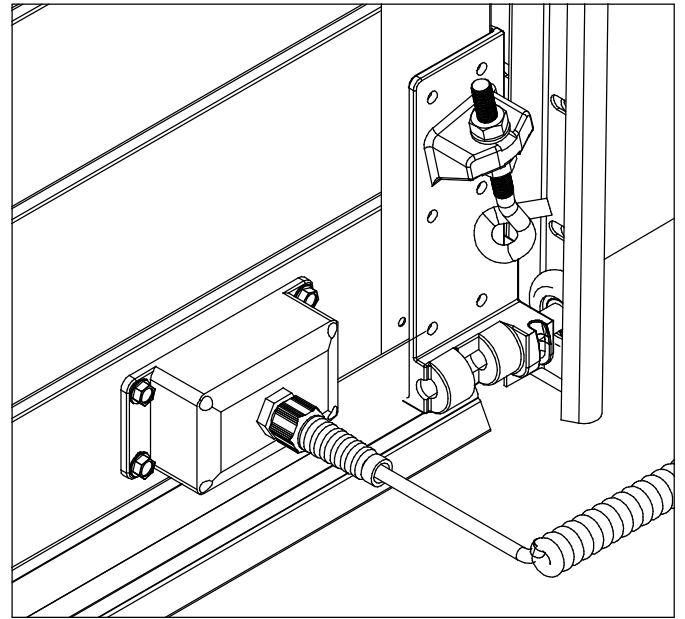
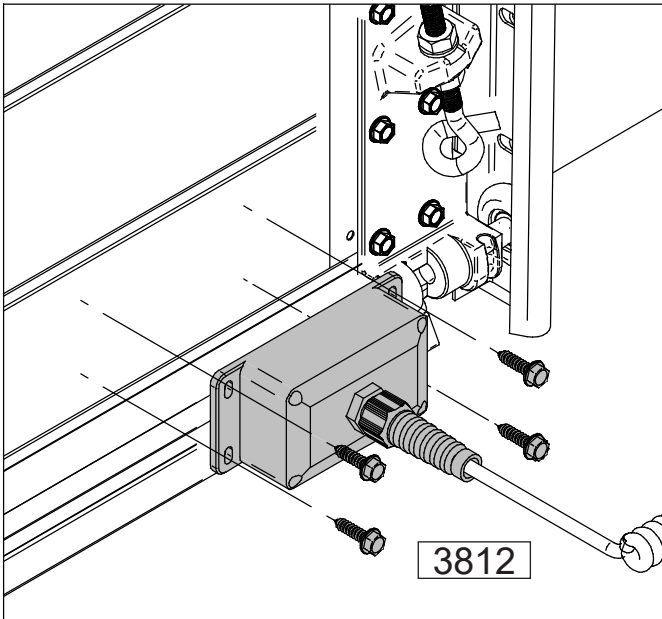



Turns x 360°

PW 12 Bon Hardware Industrie

Pitch Hiift

E

Aant Deurtype DMB DMH Secties Velden Beslag Gewicht Turns

Klant
Klant referentie:
Transport

0 0

11.4



Aant	Eenheid	Art. nr.	Artikel omschrijving	Doos	Lengte	Verpakt / Controle
1	-		Springs Left 6,00x51x950 Powdercoated			<input type="checkbox"/> <input type="checkbox"/>
1	-		Springs Right 6,00x51x950 Powdercoated			<input type="checkbox"/> <input type="checkbox"/>

VEER / FEDER / SPRING / RESSORT < 152 mm

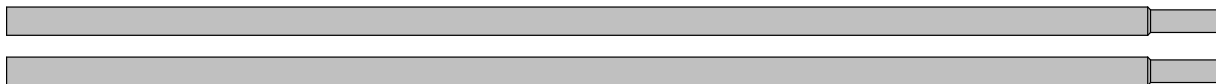

VEER / FEDER / SPRING / RESSORT < 67 mm

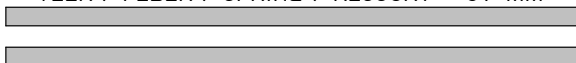

STAAL / STAHL / STEEL / ACIER 52

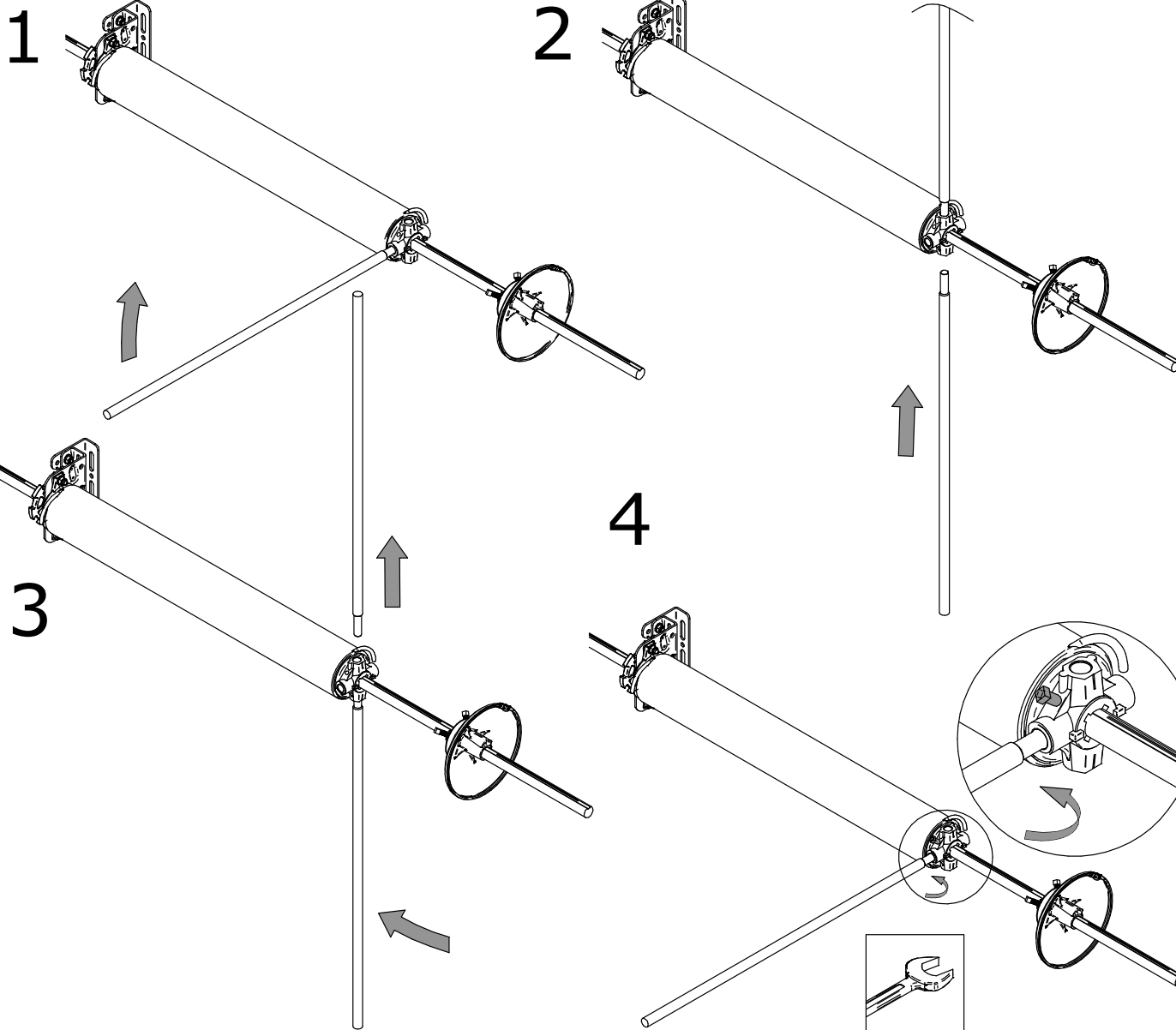

NL: Correcte wijze vastzetten van spankop
EN: Correct fastening of winding plug
DE: Richtige montage Feder spannkopf
FR: Fixation correcte du mandrin de tension

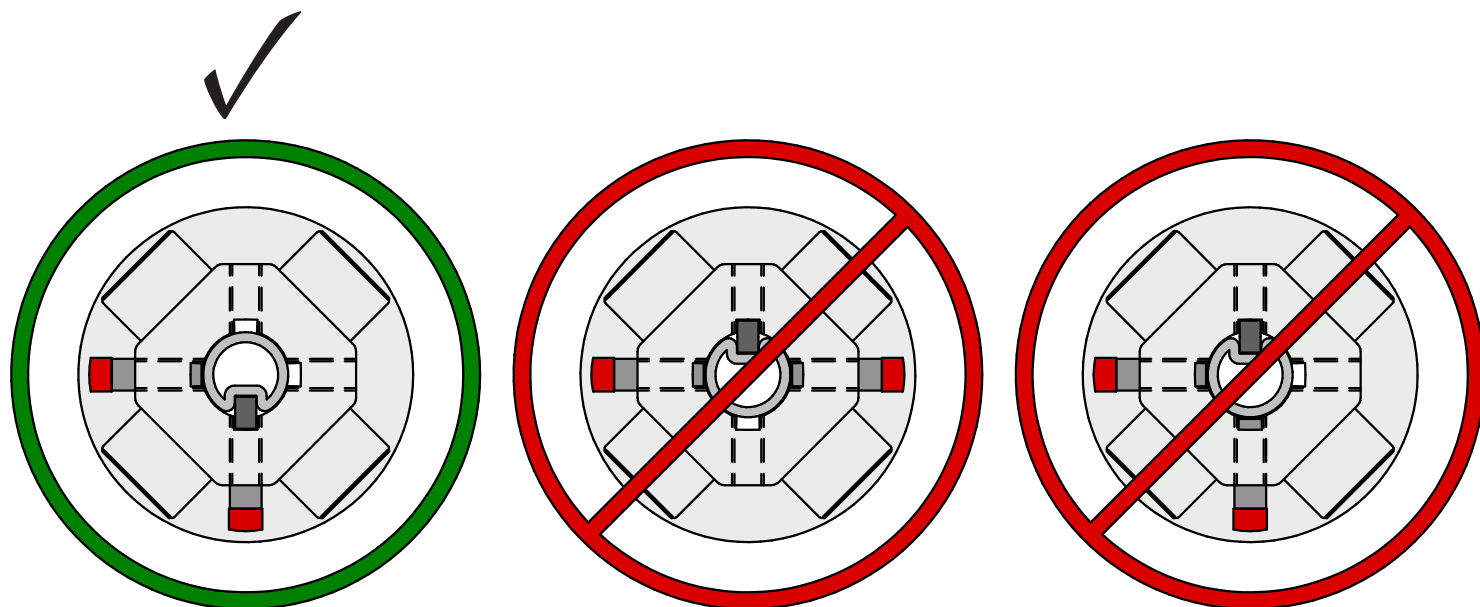

NL: Correcte wijze vastzetten van DUPLEX spankop
EN: Correct fastening of DUPLEX winding plug
DE: Richtige montage DUPLEX Feder spannkopf
FR: Fixation correcte du mandrin de tension DUPLEX

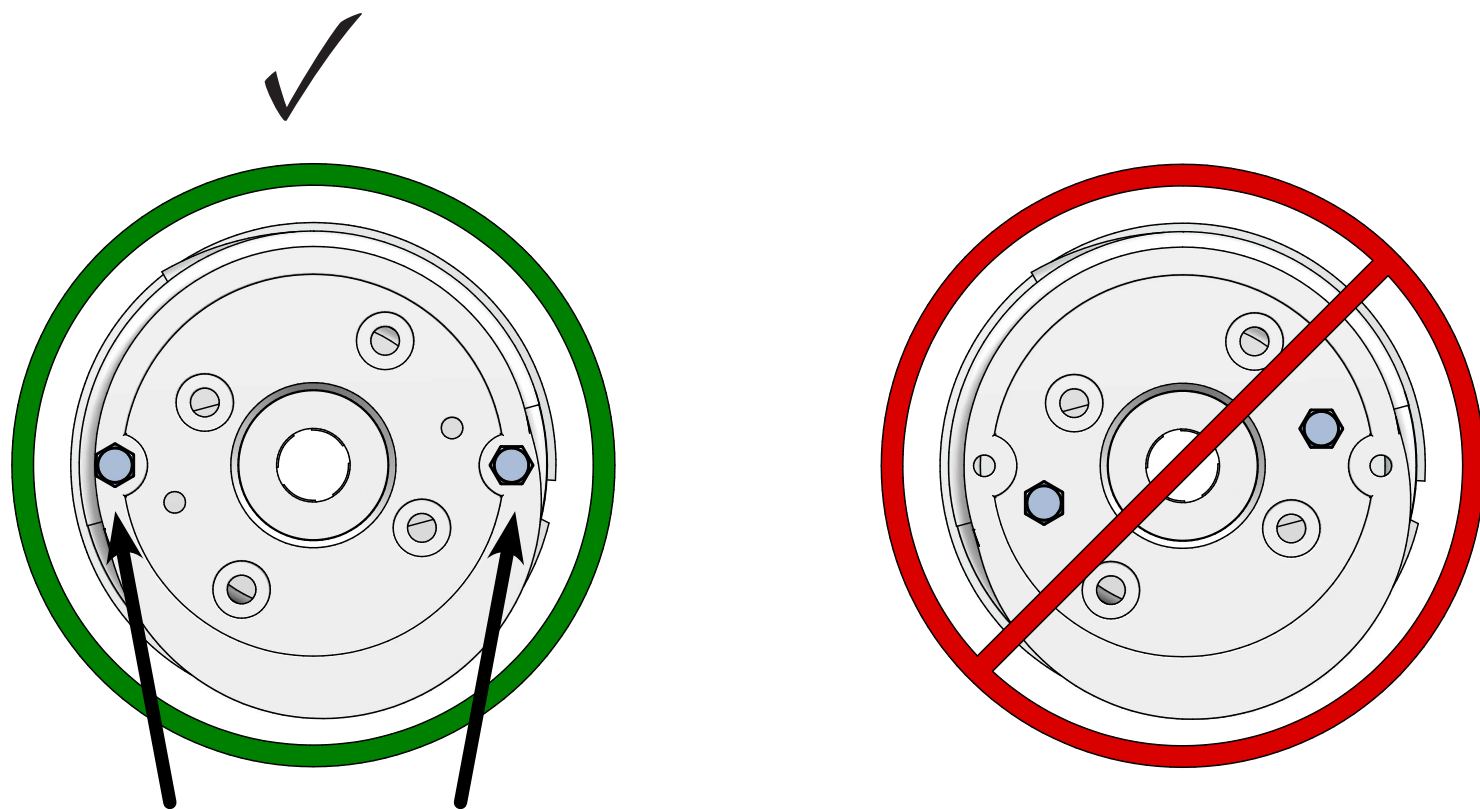

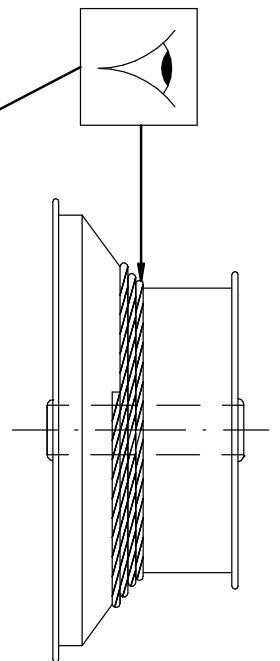
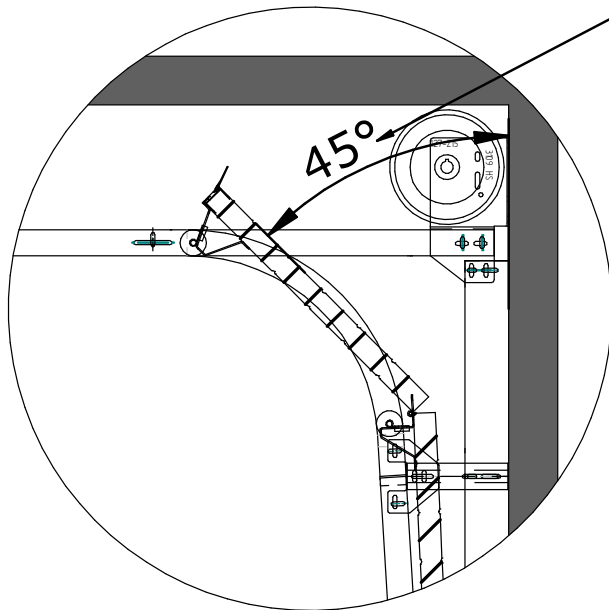
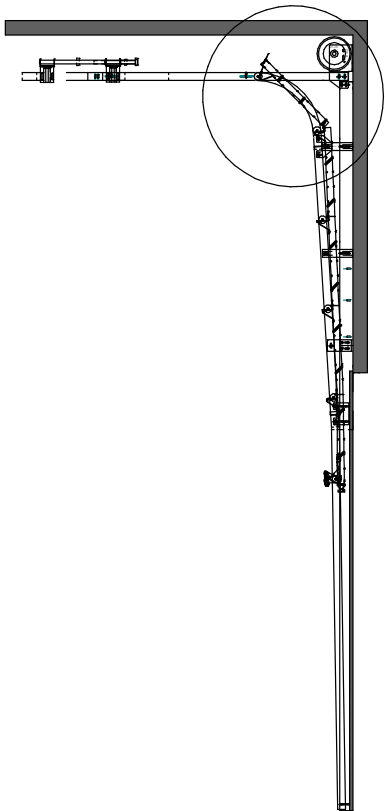
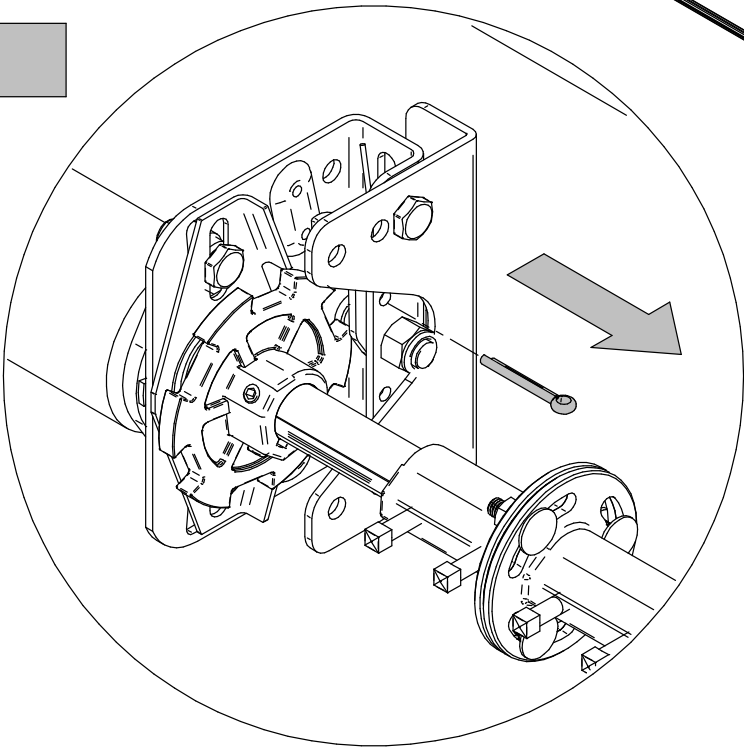
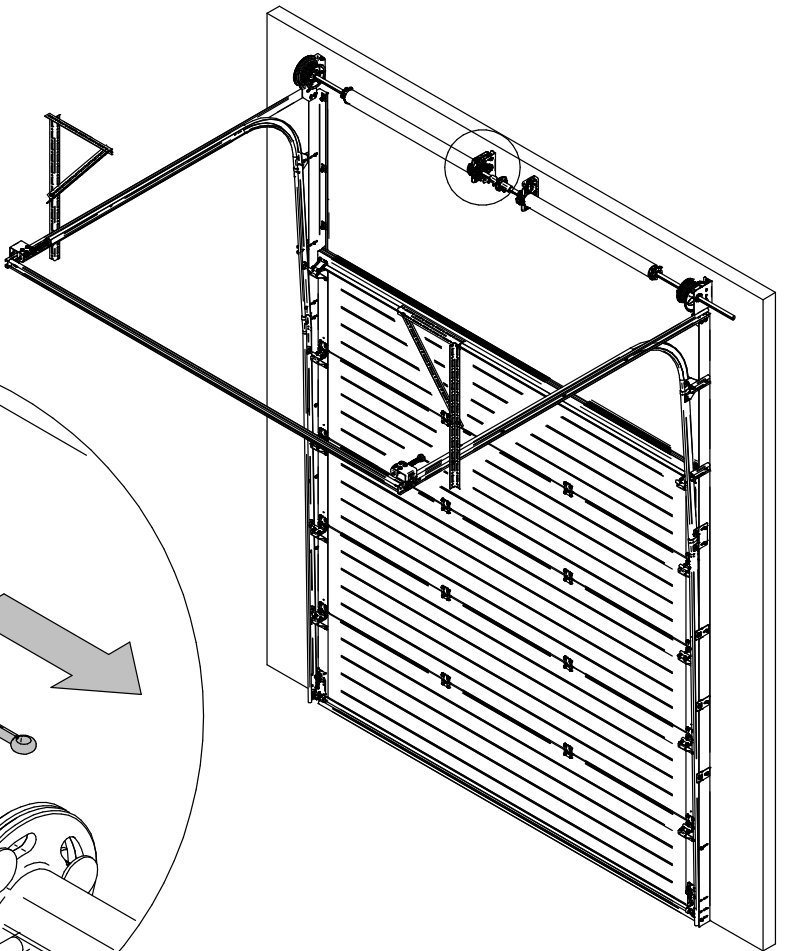
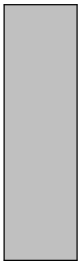

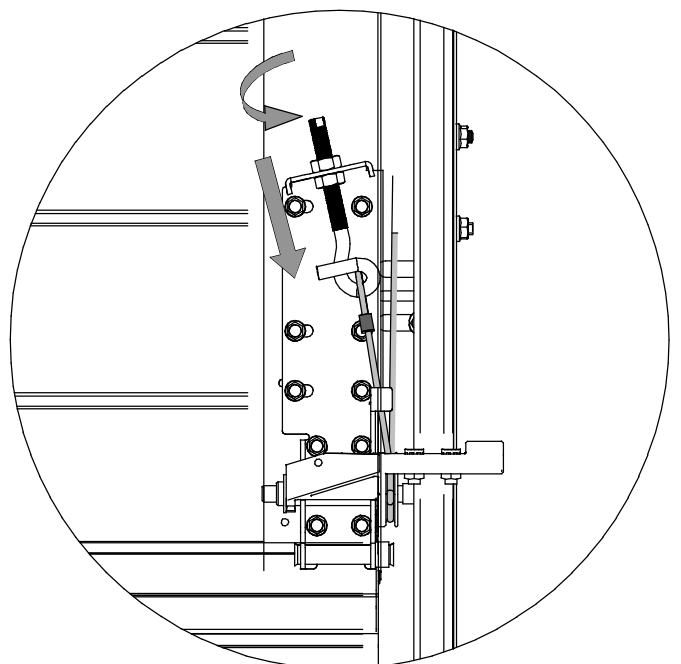
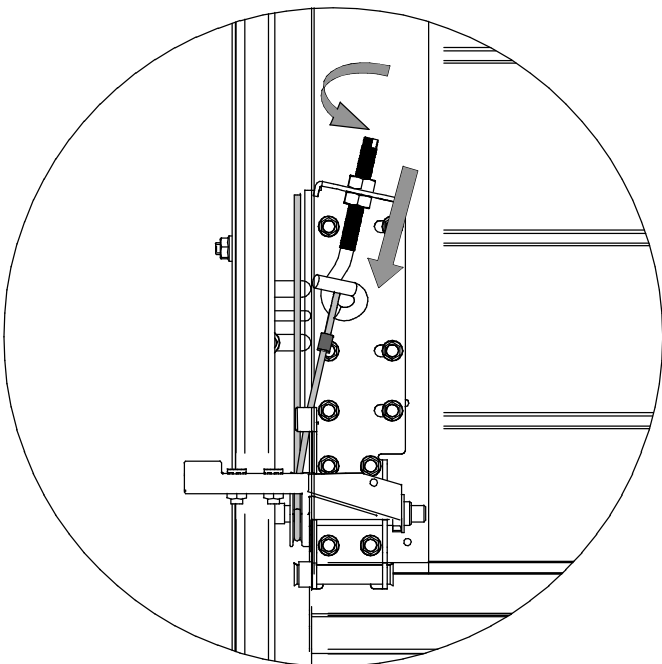
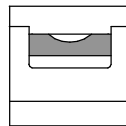
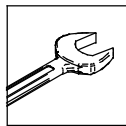
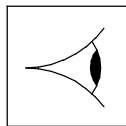
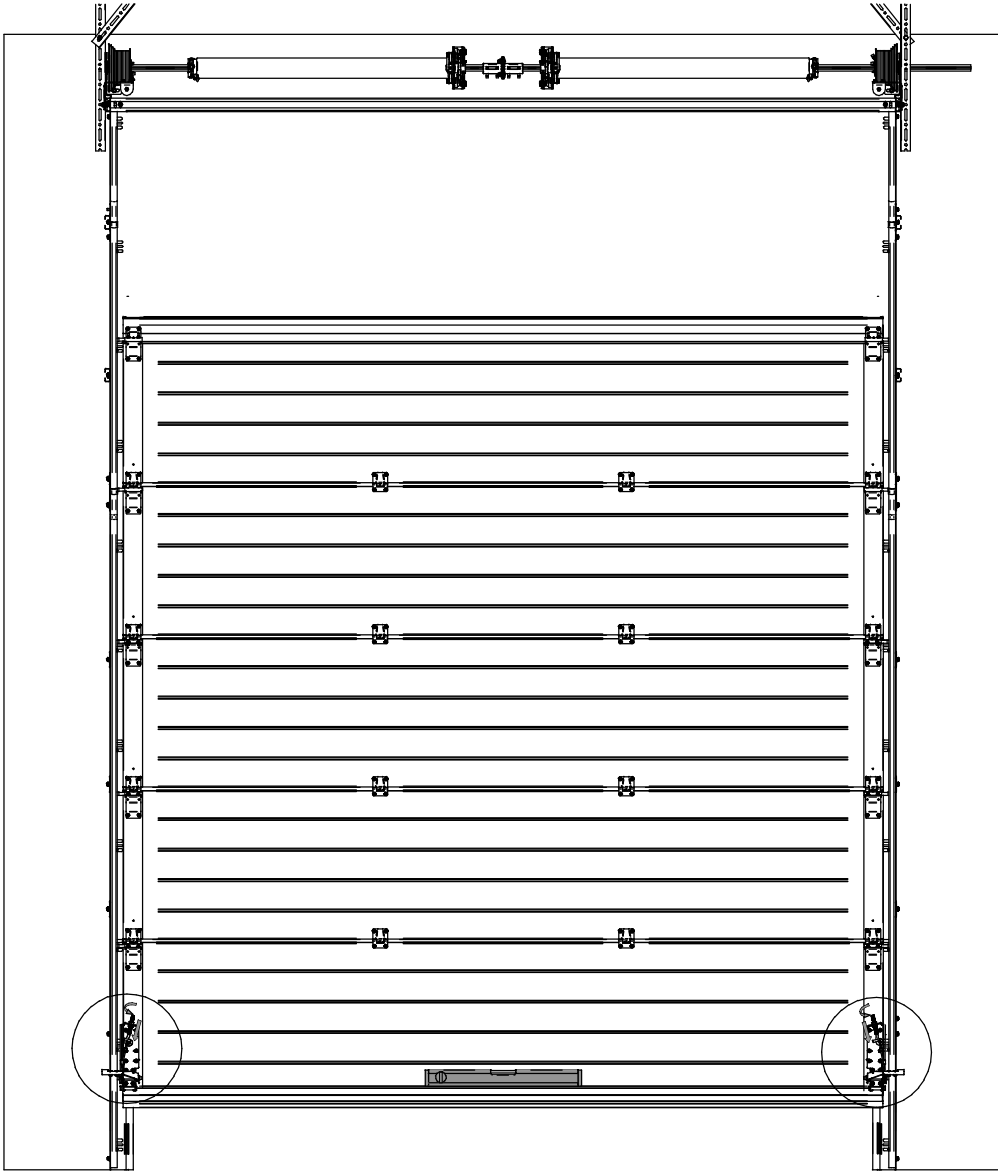

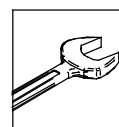
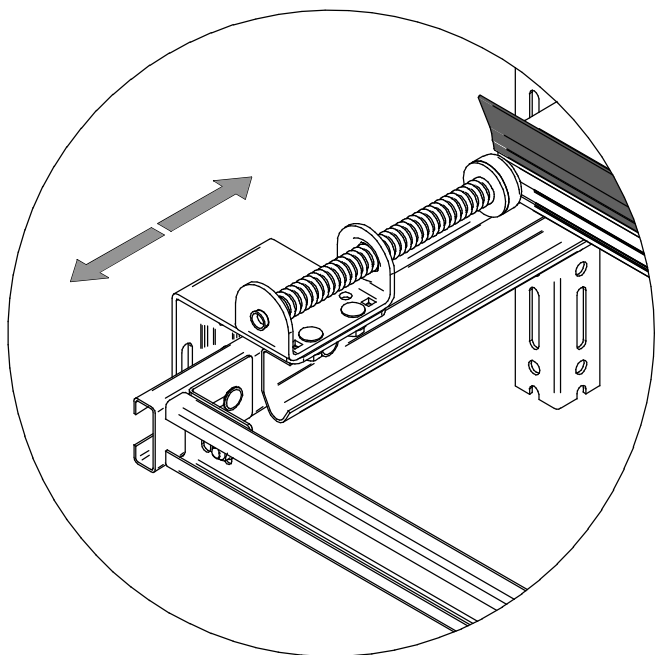
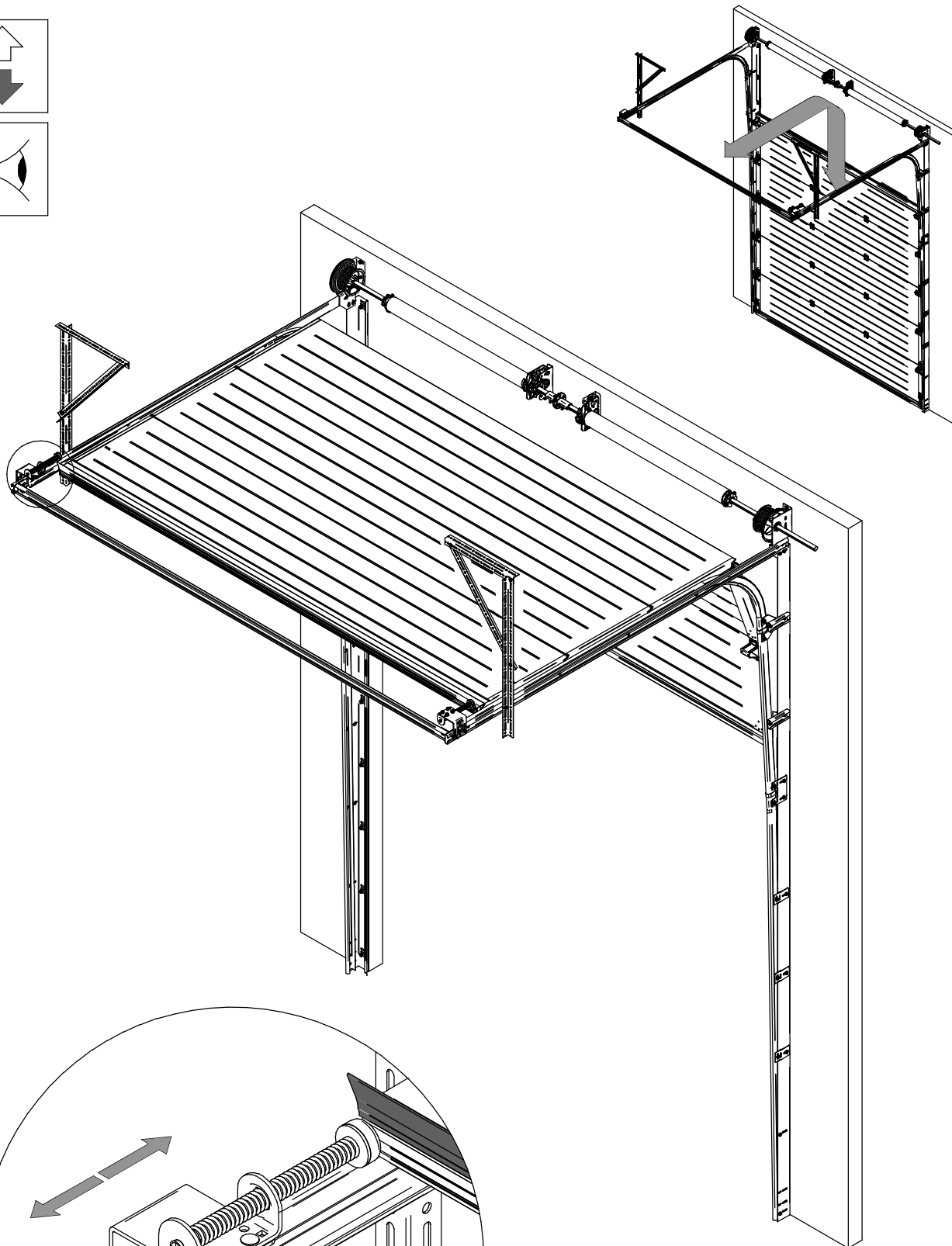
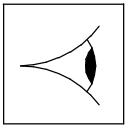
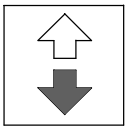

Option / Optie

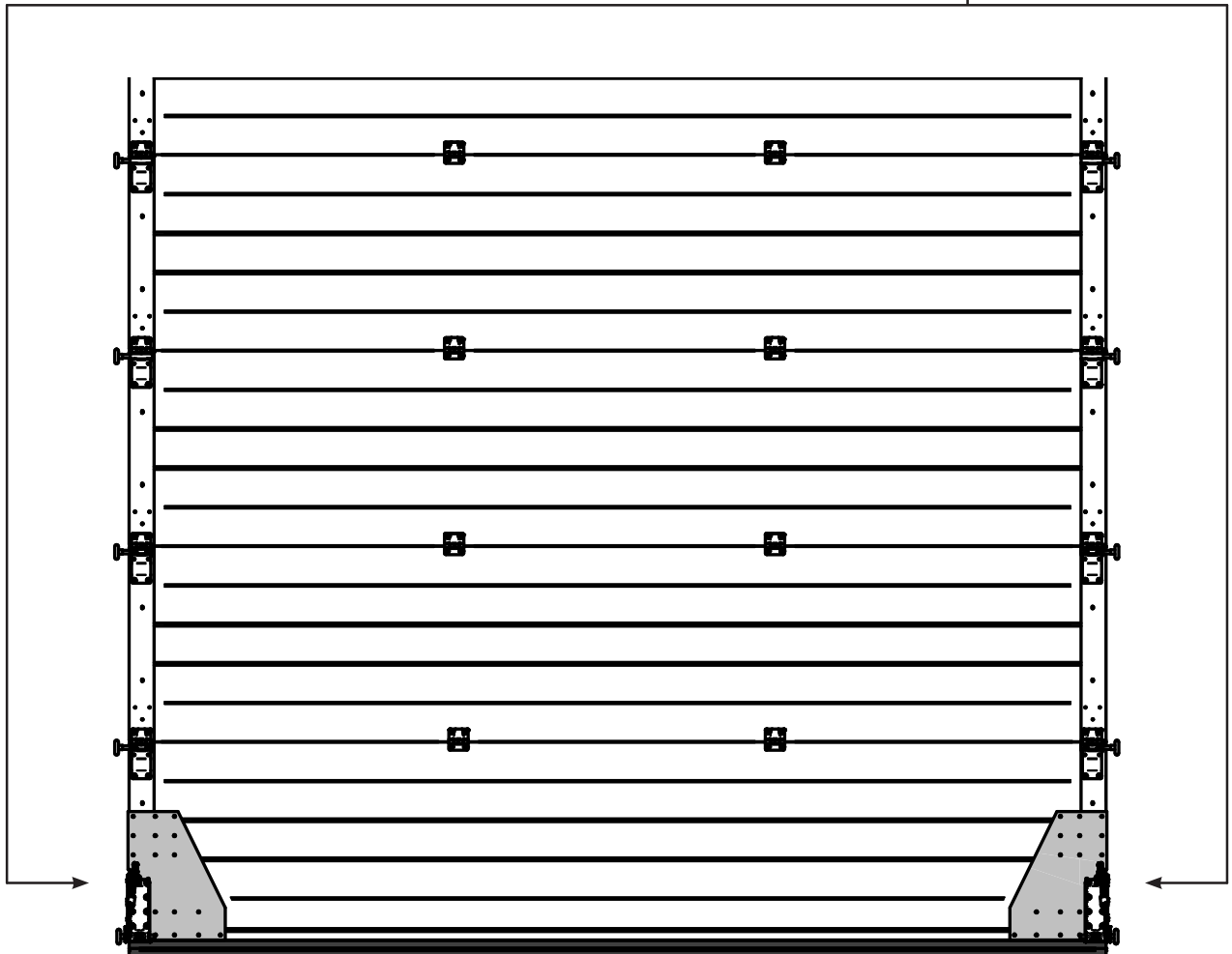
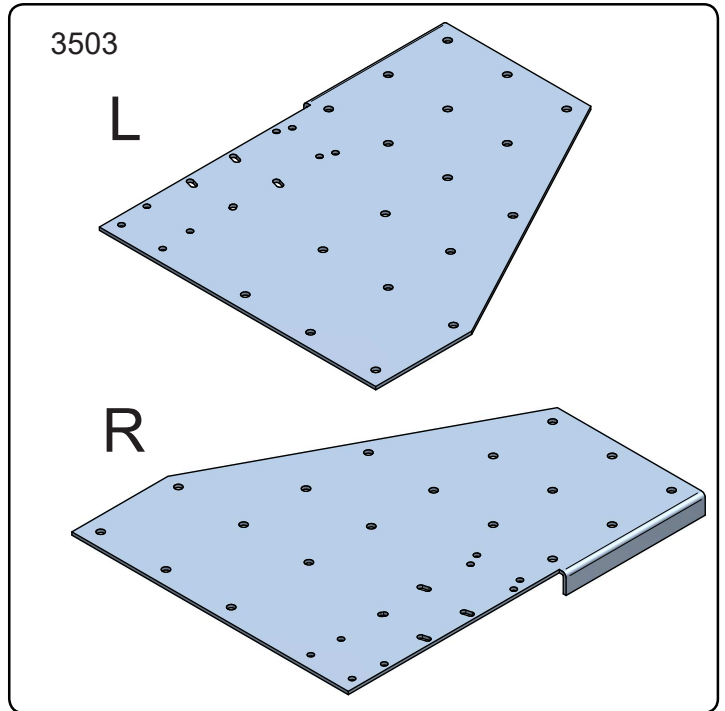
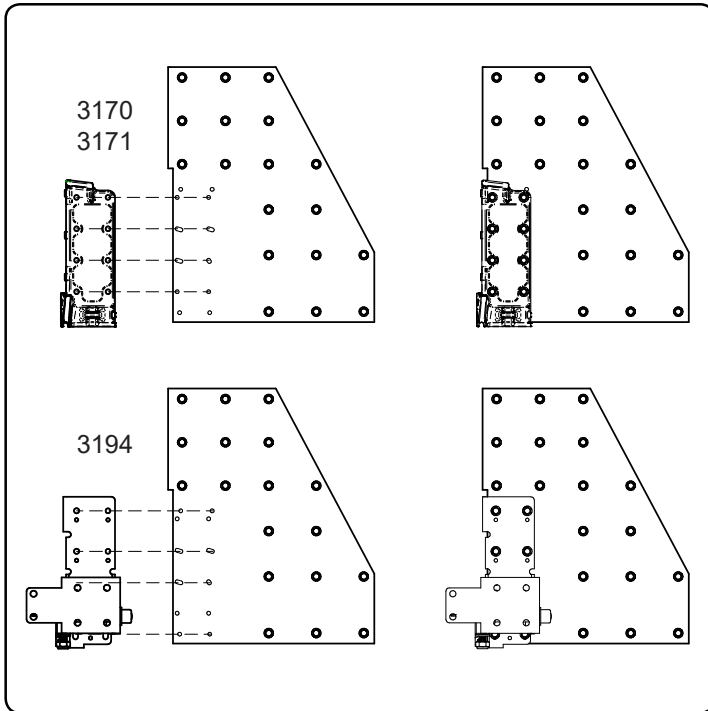

Option / Optie

3639

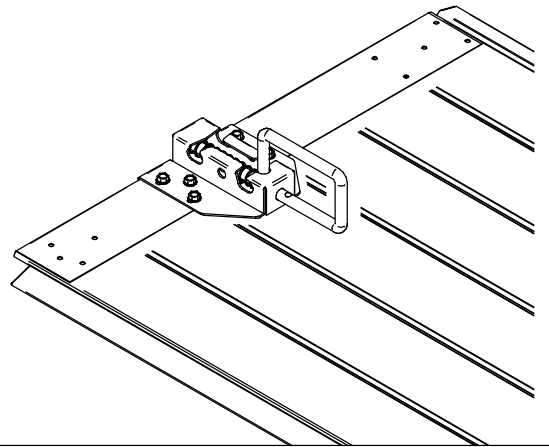
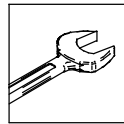
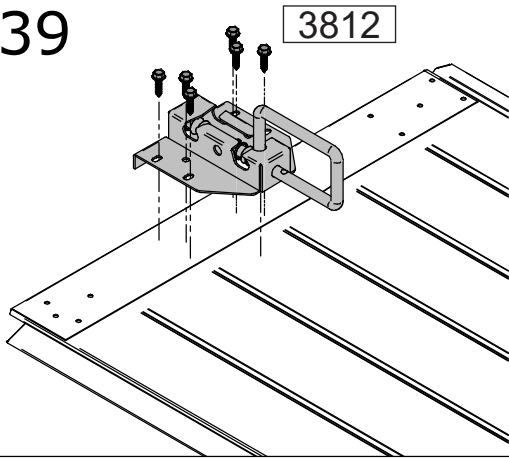

3640

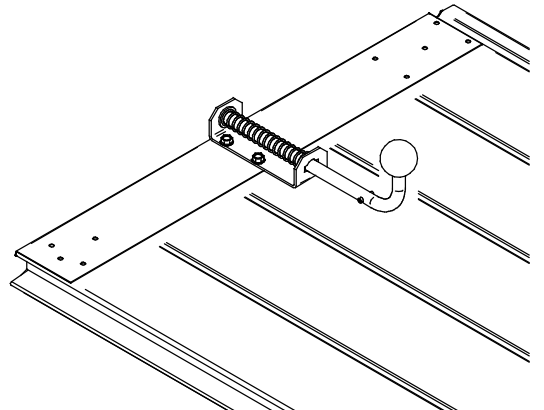
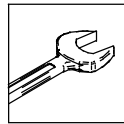
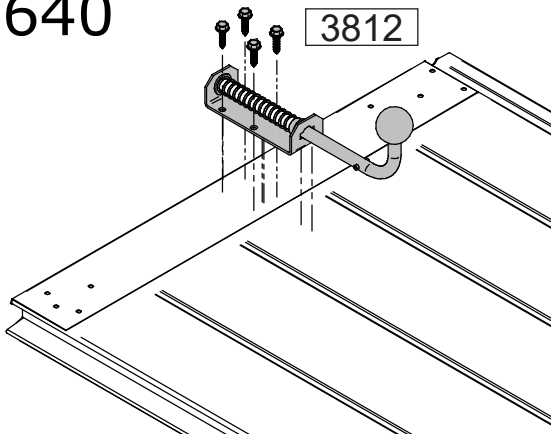

3850

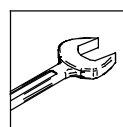
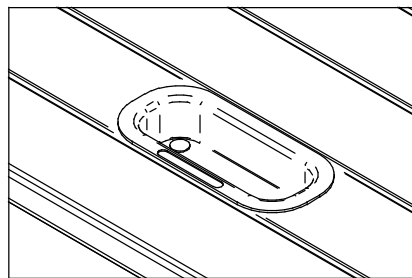
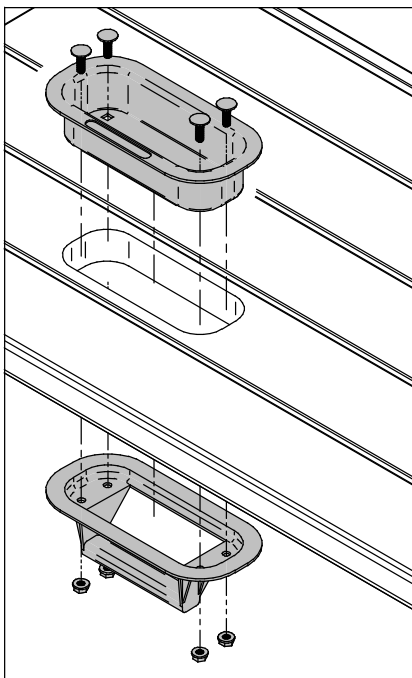

4x

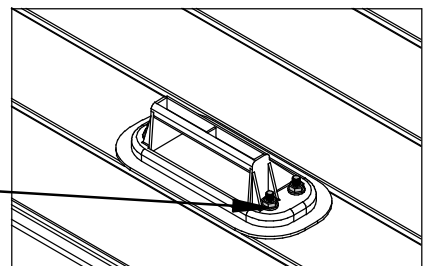

Option / Optie SCD

Parts

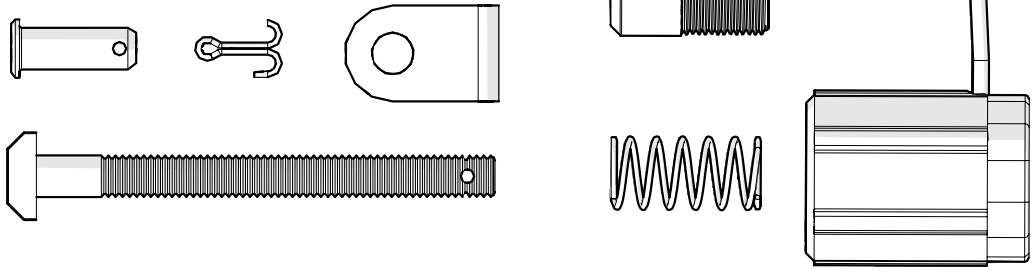

1

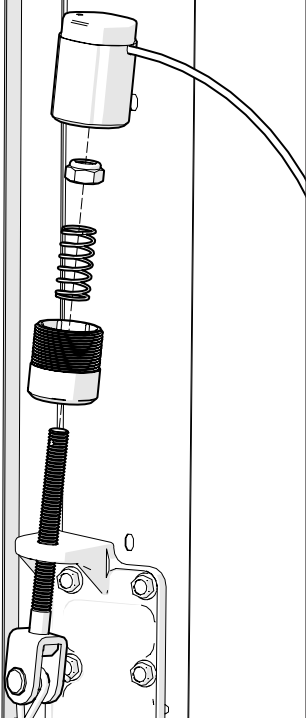

2

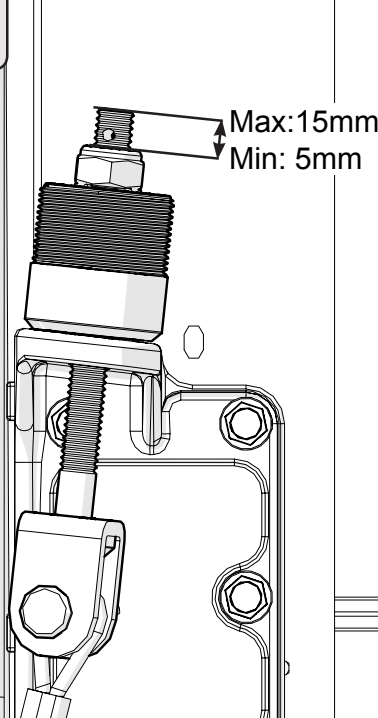

3

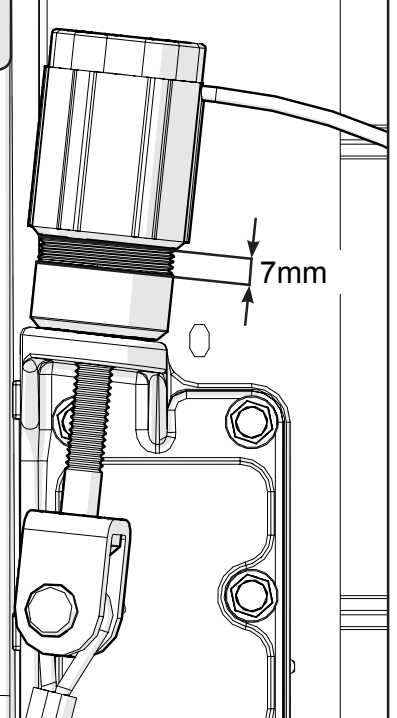

Check

NC-Switch

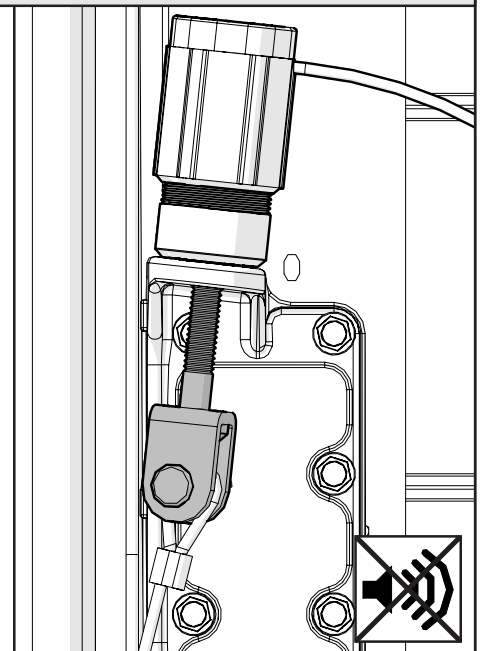
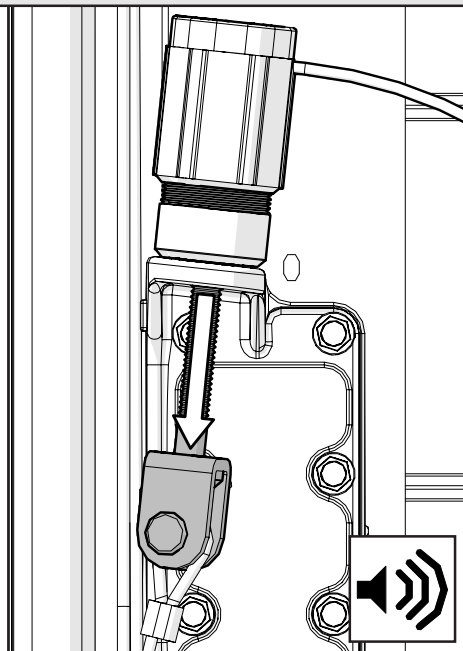
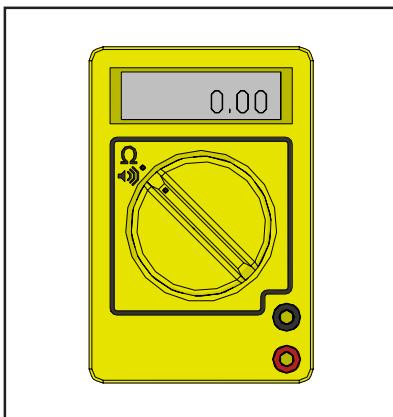

Option / Optie

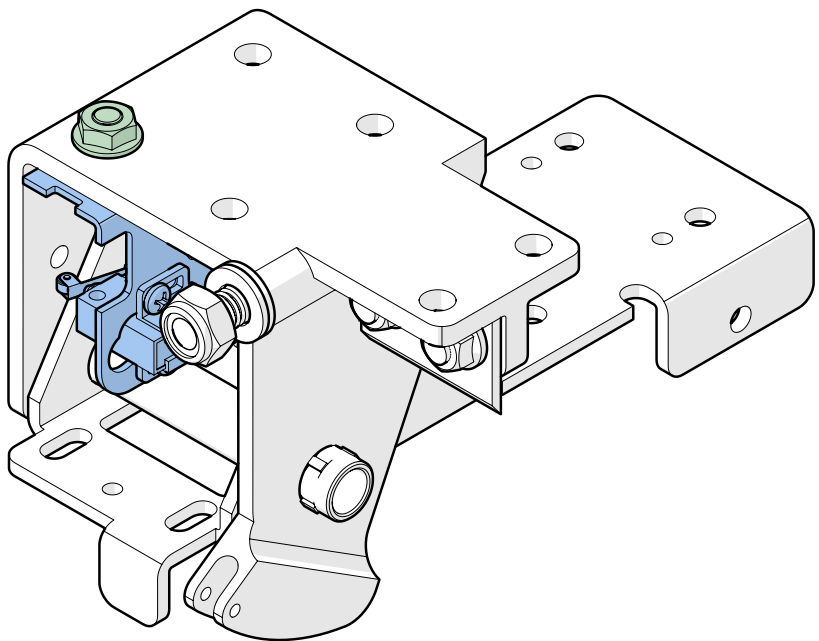
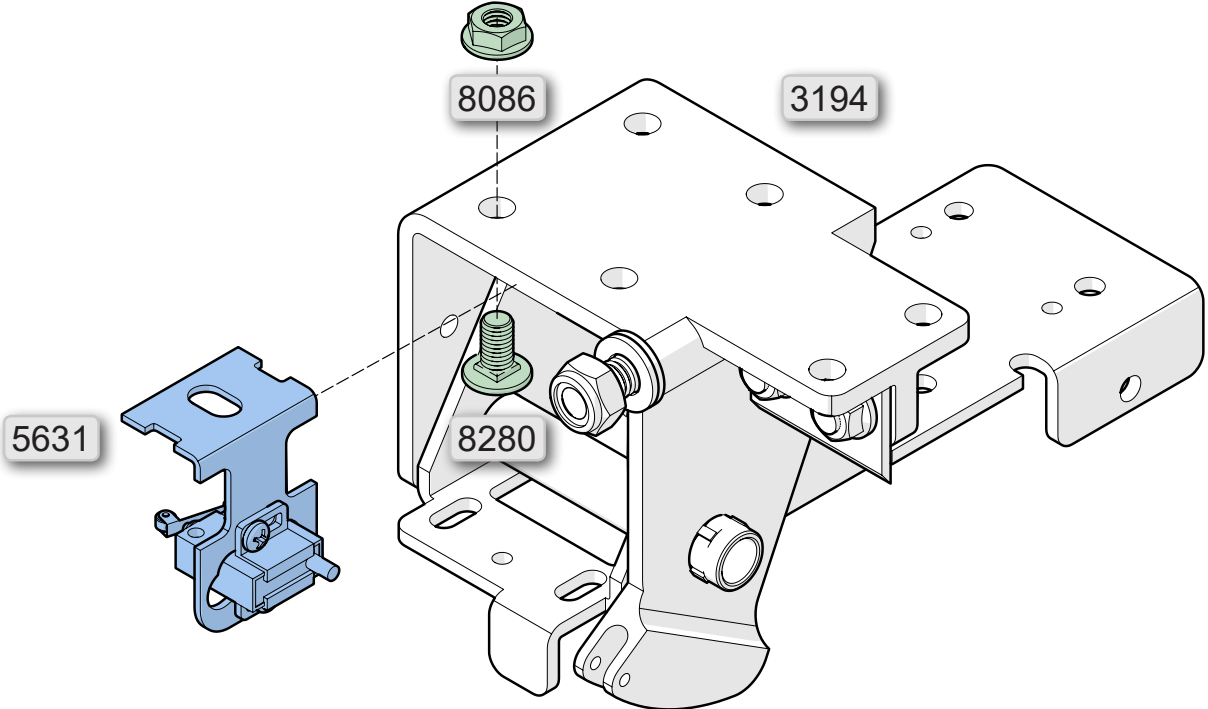

Option / Optie

NL: Lichtlijst **EN:** Light curtain **DE:** Lichtgitter **FR:** Barrières immatérielles de sécurité

NL: Montagehandleiding Lichtlijst NS/HS/VS

EN: Assembly manual Light curtain NL/HL/VL

DE: Montageanleitung Lichtgitter NS/HS/VS

FR: Manuel de montage Barrières immatérielles de sécurité LN/LH/LV

