

SECTIONAL GARAGE DOOR

Installation, Operating, and Maintenance Manual

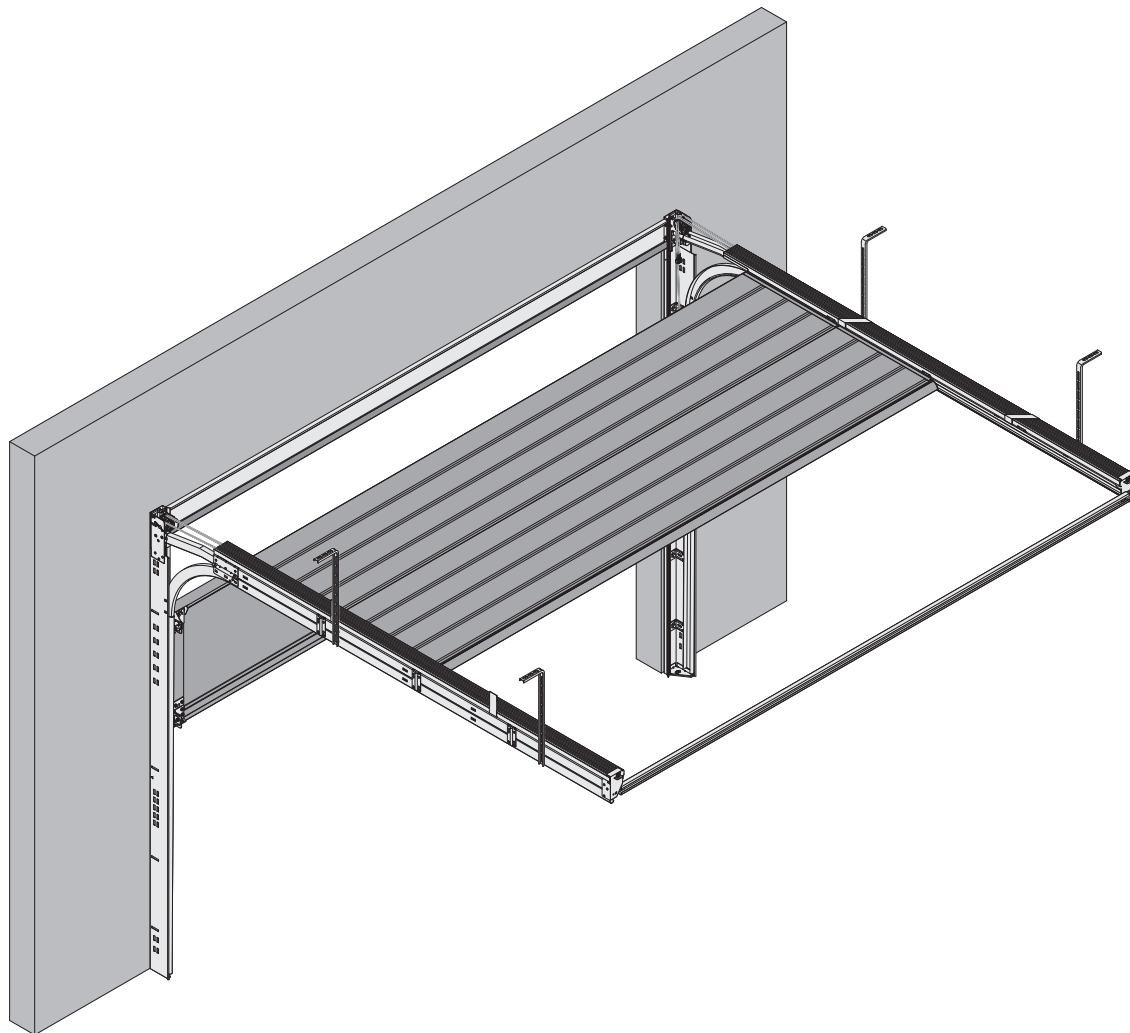

DESIGN | SAFETY | SERVICE

TECKENTRUP
DOOR SOLUTIONS

Document information

Manual for:
CarTeck sectional door

- Original manual.
- Part of the product.
- Protected by copyright.
- Reprinting, even in excerpts, is only permitted with our prior consent.

Safety information

DANGER!

Notices with the word DANGER warn of a dangerous situation that will result in death or severe injuries.

WARNING!

Notices with the word WARNING warn of a dangerous situation that can result in death or severe injuries.

CAUTION!

Notices with the word CAUTION warn of a situation that can result in minor or moderate injuries.

NOTE!

Notices with the word ATTENTION warn of a situation that can result in property damage or environmental pollution.

Explanation of symbols in text

- ⇒ Call to action
- List
- ☑ Check
- 📄 Reference to other parts of this document or other documents that must be observed

Explanation of symbols in figures

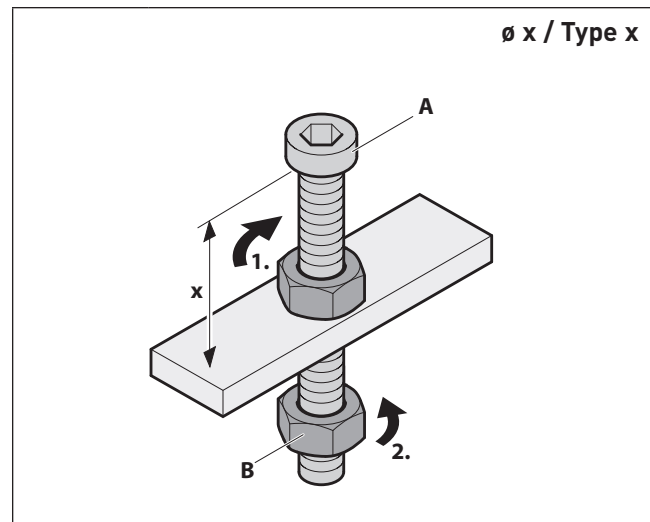

- Accentuation of action parts
- 1. Numbered action steps
- A Part names with capital letters
- x Dimensions with lower-case letters or units in mm
- ↷ Arrows indicating movement and direction
- Type** Screw type according to the overview of screws
- ø Hole diameter specification

Table of contents

1. Safety information	4	7. Service	49
1.1 Intended use	4	7.1 Maintenance work by the owner	49
1.2 Authorised target groups	4	7.2 Maintenance work by qualified, trained specialist personnel (in accordance with EN 12635)	49
1.3 General safety information	4		
2. Product information	5	8. Disassembly and disposal	50
2.1 Explanation of the colouring of CarTeck sectional doors	5	8.1 Disassembly	50
2.2 Scope of delivery	5	8.2 Disposal	50
2.3 Overview of screws	6		
3. Assembly	7	9. Annex	51
3.1 Requirements on the installation location	7	9.1 Warranty	51
3.2 Required tools (not included in the scope of delivery)	7		
3.3 Control measurement	8		
3.4 Reference level specification	9		
3.5 Lintel casing installation	9		
3.6 Frame setup	10		
3.7 Frame alignment and fixing	11		
3.8 Fastening the frame (installation in front of the reveal)	12		
3.9 Installing the lintel casing	15		
3.10 Assembly of the guide rails on the frame	16		
3.11 Assembling the double and triple spring package	19		
3.12 Assembling the quadruple spring package	20		
3.13 Installing the spring package into the spring channel	23		
3.14 Assembly of the wire rope	23		
3.15 Assembly of the spring channel cover	25		
3.16 Assembly of the guide rails on the ceiling	27		
3.17 Assembly of the door sections	31		
3.18 Assembly of the wire rope on the door leaf	42		
3.19 Spring tension adjustment	43		
3.20 Door carrier assembly	45		
3.21 Pull rope assembly (optional accessory)	45		
4. Commissioning	46		
4.1 Safety instructions for commissioning	46		
4.2 Testing the door operation	46		
4.3 Remove protective film	47		
5. Operation	48		
5.1 Safety instructions for operation	48		
5.2 Manually operated doors	48		
5.3 Power-operated doors	48		
6. Cleaning	49		

1. Safety information

1.1 Intended use

- This garage door is intended exclusively for private use (approx. 1000 cycles / year).
- Continuous operation is not permitted.

1.2 Authorised target groups

- Assembly, connection, commissioning and disassembly:
qualified, trained specialist personnel.
- Operation, testing, and maintenance:
Owner of the door system.

Requirements for qualified and trained specialist personnel:

- Knowledge of the general and special safety and accident prevention regulations.
- Knowledge of the applicable electrical engineering regulations.
- Training in the use and upkeep of appropriate safety equipment.
- Adequate instruction and supervision by electricians.
- Capability of recognising dangers which can be caused by electricity.
- Skill in the application of the following standards
 - EN 12635 ("Industrial, commercial and garage doors and gates. Installation and use"),
 - EN 12453 ("Industrial, commercial and garage doors and gates. Safety in use of power operated doors. Requirements"),
 - EN 12445 ("Industrial, commercial and garage doors and gates. Safety in use of power operated doors. Test methods").

Requirements for the owner of the door system:

- Familiarity with and safekeeping of the operating manual.
- Knowledge of the general safety and accident prevention regulations.

Special requirements apply for the following users:

- Children ages 8 and older.
- Persons with reduced physical, sensory, or mental capabilities.
- Persons lacking in experience and knowledge.

These users may only be involved in the operation of doors.

Special requirements:

- Users are supervised.
- Users have been instructed with regard to the safe use of the equipment.
- Users understand the dangers involved with the equipment.
- Children must not play with the equipment.

1.3 General safety information

Keep this manual safe for future reference!

Please read and observe this manual! It provides you with important information about the safe installation and operation of the sectional garage door. The proper care and maintenance of your door is also described here so that you can benefit from this product for many years to come.

WARNING!

- Installation may only be carried out by a qualified expert in accordance with EN 12635.
- For your own safety, you must carry out the installation steps in the sequence specified in this manual.
- Only assemble the door on foundations with the appropriate structural support.

2. Product information

2.1 Explanation of the colouring of CarTeck sectional doors

Possible deformation from solar radiation

Thermally insulated sectional doors having foam panels consisting of an outer and inner skin (steel sheet) are subject to an elevated level stress during the summer months in particular.

A significantly higher temperature arises on the outside of the door leaf than on the inside due to direct solar radiation.

Therefore, the outer skin of the panel expands significantly more than the inner skin, which can result in temporary deformation of the door leaf.

This effect occurs especially with very dark colours.

In general, the following applies: The lighter the colour, the less the deformation.

Exceptions are metallic, pearlescent and fluorescent colours, which can heat up significantly with lighter colours.

The same applies for film-coated doors in faux wood décor, such as dark oak, mahogany, etc.

In addition, the deformation increases as the width of the door increases.

Therefore, the surface of door systems in dark colours will never be completely level.

The panels are produced at the factory to counteract any deformation.

Planning

We recommend taking this into consideration when planning the door system.

If the door system is exposed to direct solar radiation, a pronounced deformation of the panels must be taken into account, depending on the type and design of the door.

Remedy for thermal deformation

Reinforcement profiles on the panels do not usually provide the desired effect and reduce the passage height.

In order to avoid deformation due to direct solar radiation, the "Special bracket for sectional doors" (Article number 138 144) can be used with the 120 series fitting.

In this connection, the top rollers must be positioned in the same manner as with manually operated doors. As a result, the top roller is in the vertical curved rail when the door is closed and counteracts deformation. With the 240 series fitting, the top rollers must always be positioned in the same manner as with manually operated doors.

It must also be ensured that distance between the door leaf and drive rail is not at the minimal end of the range in order to avoid damage to the door leaf. The indicated measures can positively influence the effects, but not eliminate them entirely.

Informing end customers

The end customer must always be informed of the problem and any measures must be coordinated with them ahead of time.

The customer must also be informed that deformation of the door must be taken into consideration with the aforementioned door colours and intense solar radiation and that this is not a defect.

2.2 Scope of delivery

- Door leaf package
- Frame package
- Accessory package

2.3 Overview of screws

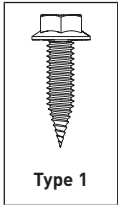

Type 1:
Screw 6.3 x 16

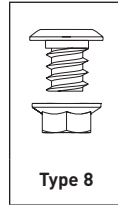
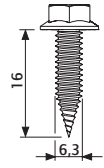

Type 8:
Screw M8 x 13

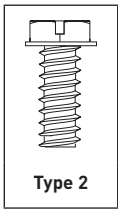
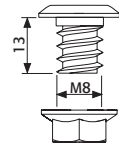

Type 2:
Screw 4.2 x 13

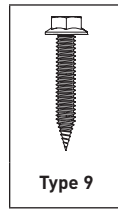
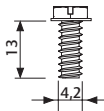

Type 9:
Screw 6.5 x 25

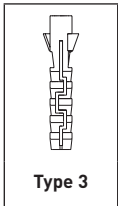
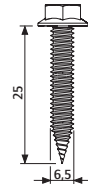

Type 3:
Anchor

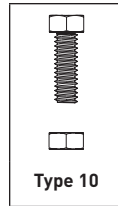
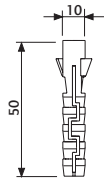

Type 10:
Screw M8 x 30

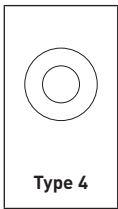
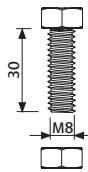

Type 4:
Washer
8 x 19

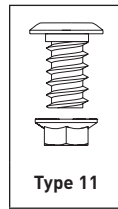
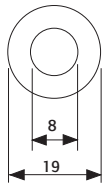

Type 11:
Screw M6 x 16

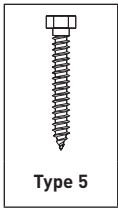
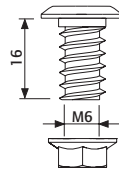

Type 5:
Screw 8 x 60

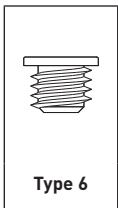
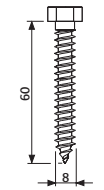

Type 6:
BN 9524
Screw M8 x 8 / T25

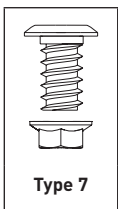
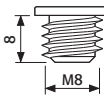

Type 7:
Screw M8 x 16

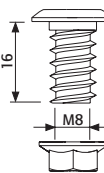

3. Assembly

3.1 Requirements on the installation location

- ⇒ Please ensure the following for the installation location:
- the floor is completed at the finished height,
 - the walls and ceiling are plastered.

In order to eliminate the risk of corrosion:

- ⇒ Assure that water drains sufficiently from the outside area in front of the door seal and frame parts! If necessary, plan an incline for drainage!
- ⇒ Ensure that there is adequate drying and/or ventilation of the hall!
- ⇒ Protect the door from aggressive and corrosive media, such as saltpetre reactions from stone and mortar, acids, alkali, road salt, aggressive varnishes or sealants!
- ⇒ The door must be covered prior to any plastering or paintwork, because splatter from mortar, cement, gypsum or paint can damage the surface.

3.2 Required tools (not included in the scope of delivery)

- Two wooden trusses or other means of support
- 2–3 wood blocks / linings
- Drill
- Drill bit
- Torx T-25
- 4 mm Allen wrench
- 8 mm Allen wrench
- AF 7 socket wrench
- AF 13 socket wrench
- AF 10 spanner
- AF 13 spanner
- Suitable anchors for the specific installation situation: Aerated concrete
- Screwdriver
- Metal saw
- Pliers
- Protective goggles
- Screw clamps
- Ladder or assembly scaffolding
- Spirit level
- Hose spirit level for reference level specification
- Measuring tape
- Work gloves

3.3 Control measurement

NOTE!

⇒ Before beginning with installation, check whether the delivered door is suitable for the installation situation.

3.3 / 1

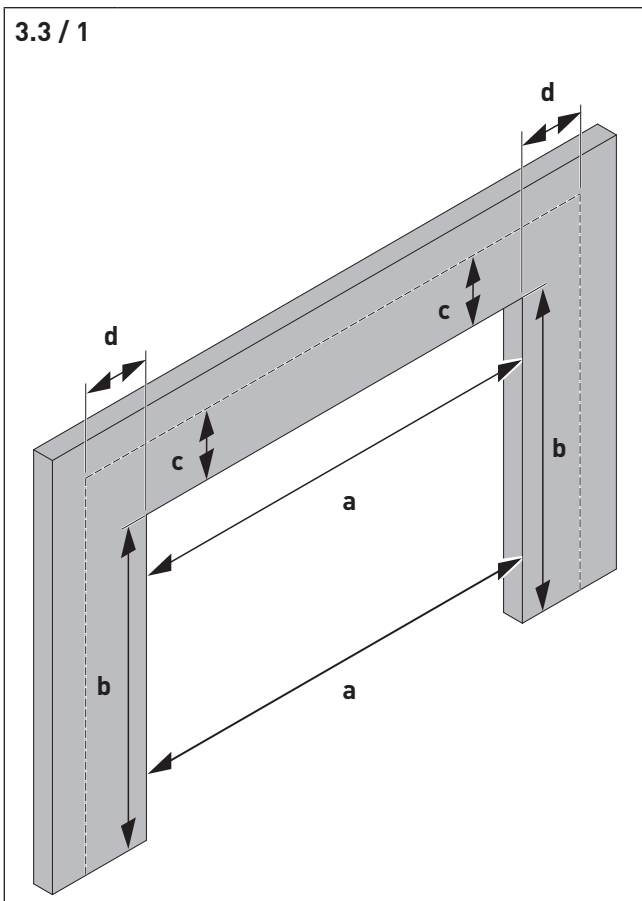

⇒ **Take the following measurements on the inside of the door opening:**

- a** The passage width at the top and bottom of the door opening.
The delivered opening dimension must match the door width opening.
- b** The passage height at the right and left sides of the door opening.
The delivered opening dimension must match the required clearance.

- c** The vertical drop at the right and left sides of the door opening.
 - The vertical drop must be at least 120 mm (for doors with a drive).
 - The vertical drop must be at least 145 mm (for very large doors with a drive and 4-way spring channel).
 - The vertical drop must be at least 240 mm (for manually operated doors with outside handle).
 - The vertical drop must be at least 265 mm (for very large manually operated doors with outside handle).
- d** The lateral space required to the left and right of the door opening must be at least 85 mm.

Functional check

When all 4 requirements are met, you can proceed with installation.
Please refer to the order for the opening dimensions of the door.

3.4 Reference level specification

NOTE!

- Correct installation of the side frame is important; ensure that the door completely covers the opening and is not installed askew.
- The reference level only applies for standard grid heights. With special heights (shortened frame), the height specification of the frame must be transferred to the structure!

3.4 / 1

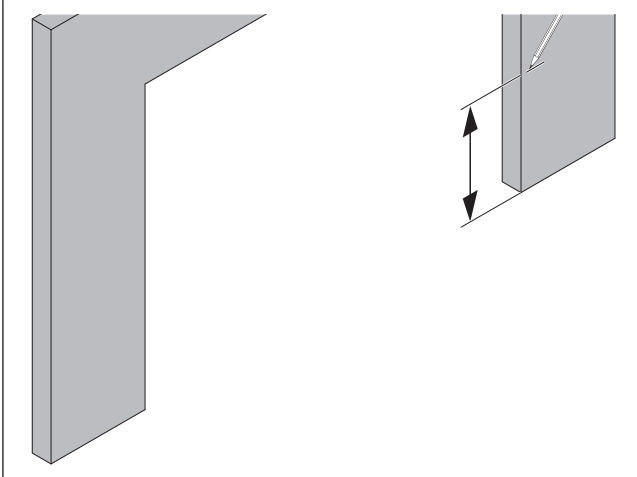

- ⇒ Draw a mark on one of the sides of the opening: **one metre** from the **upper edge of the finished floor** (UFF).

3.4 / 2

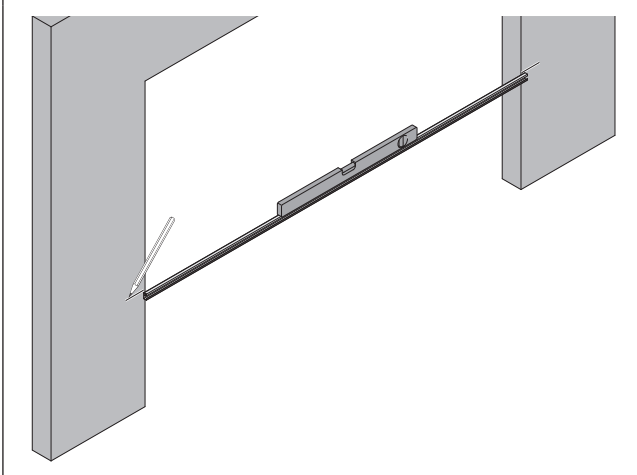

- ⇒ Using the rear cross strut and a water scale, transfer the measurement on the other side (a hose spirit level can also be used for this purpose).
- ⇒ Measure the transferred height. The height must be **at least 1 m**.

If a height of 1 m from the floor is undercut when transferred to the other side, the reference level must be transferred from this side!

3.5 Lintel casing installation

3.5 / 1

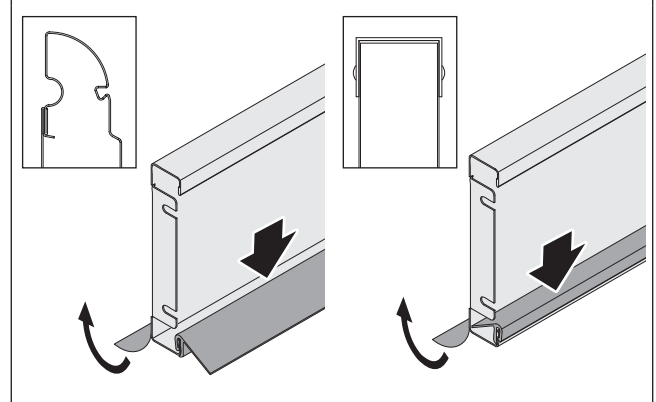

- ⇒ Remove the protective film of the lintel casing.
- ⇒ Fit the headroom seal on the lintel casing.

3.5 / 2

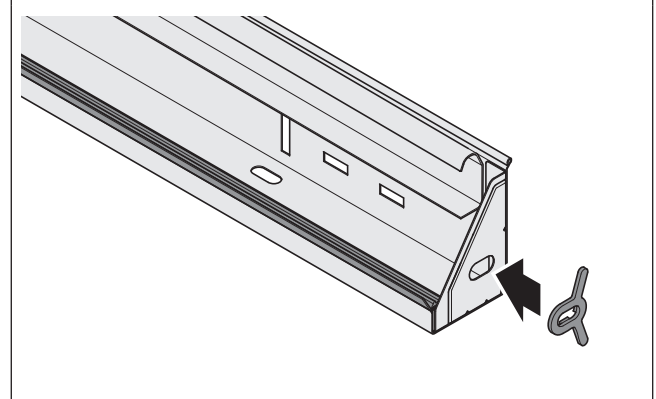

- ⇒ Insert the frame spacer into the gusset plate in the frame from below.

NOTE!

- The elements must not be damaged.
- The surface of the frame must not be scratched.
- The elements must be fastened flushly on the outside.

3.5 / 3

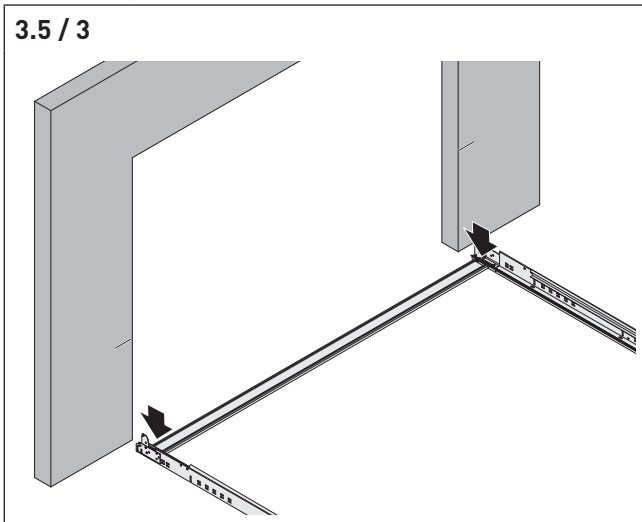

⇒ Connect the vertical frame to the lintel casing.

3.5 / 4

Type 2

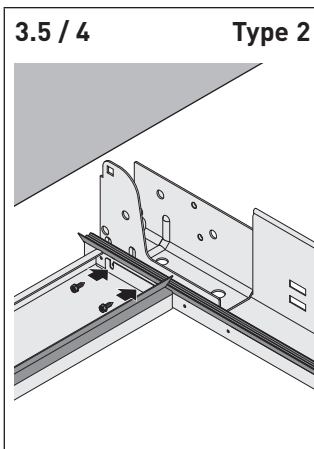

3.5 / 5

Type 2

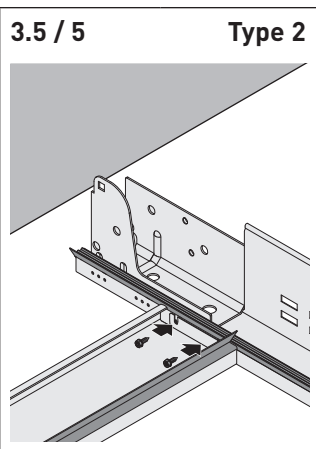

⇒ Fasten the elements on each side with 2 metal screws:

- Lintel variant 120 mm: Fig. "3.5 / 4"
- Lintel variant 240 mm: Fig. "3.5 / 5"

⇒ Tighten the screws.

⇒

3.6 Frame setup

The frame can be installed depending on the installation site situation **in front of the reveal** or **in the reveal**.

- 📄 "3.8 Fastening the frame (installation in front of the reveal)"
- 📄 The supplied supplementary sheet must be observed (installation in the reveal)

The following figures show the situation for installation in front of the reveal.

⚠ WARNING!

- Alignment of the frame must be carried out by two persons.
- The frame must not be warped or canted during alignment.

3.6 / 1

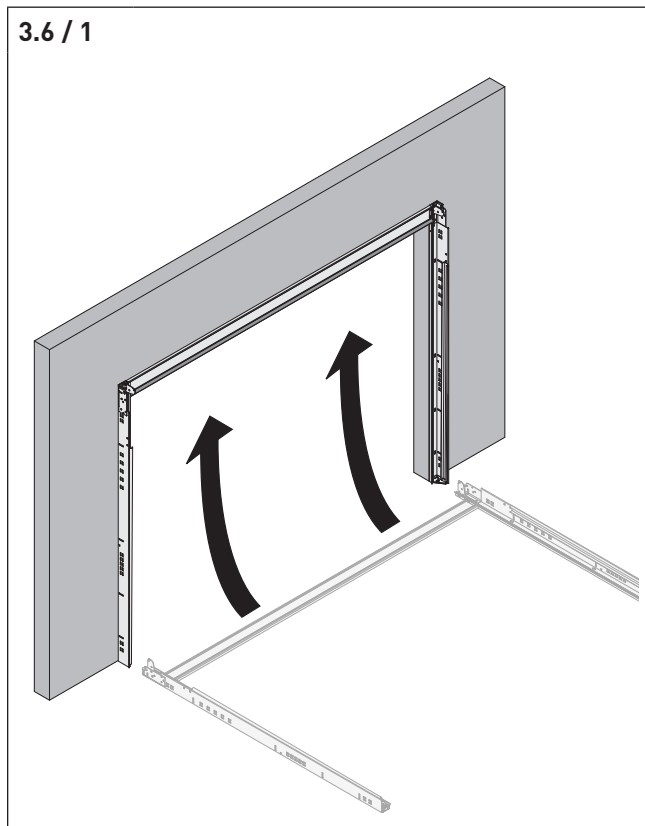

⇒ Position the pre-assembled internal frame in front of the opening.

3.7 Frame alignment and fixing

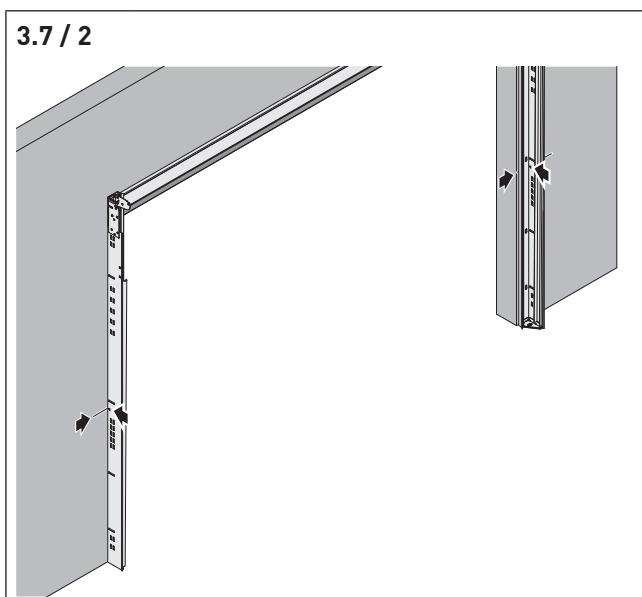
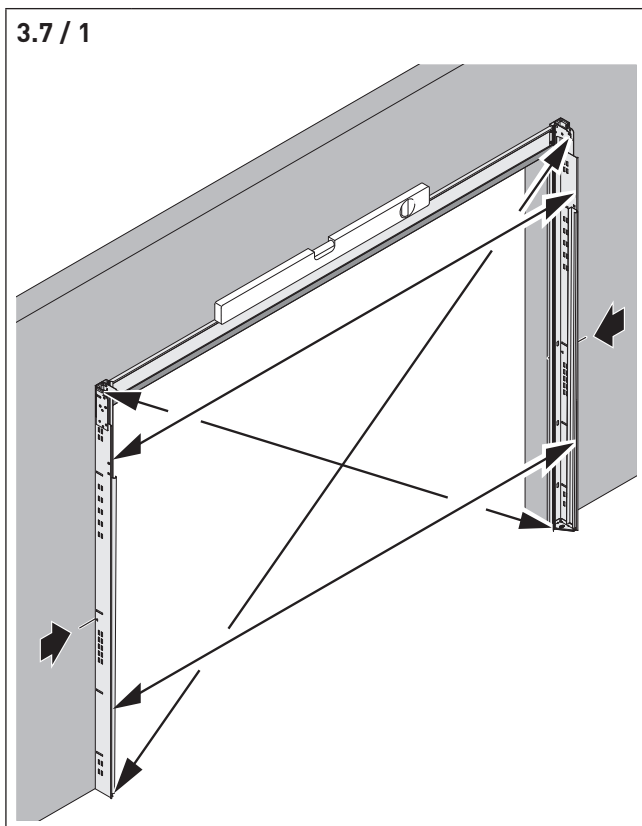

- ⇒ Align the frame centred on the door opening.
- ⇒ Apply the punched mark of the frame on both sides flush with the mark on the masonry.

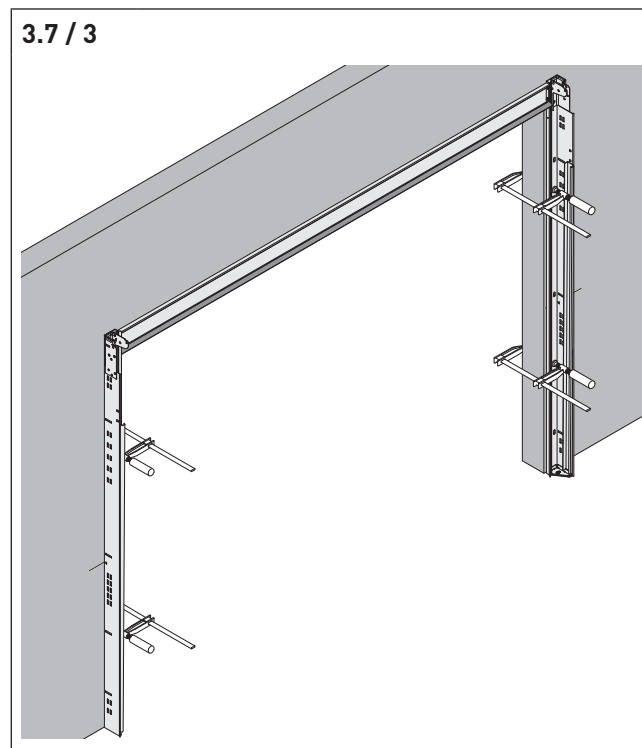

- ⇒ Fix the position with screw clamps.
- ⇒ Measure the distance to the frame above and below (Fig. "3.7 / 1").
The distances must be equal above and below.
Frame clearance measurement = width order measurement
- ⇒ Check the diagonal measurements (Fig. "3.7 / 1").
- ⇒ Check whether the frame is fixed horizontally in the door opening (Fig. "3.7 / 1").

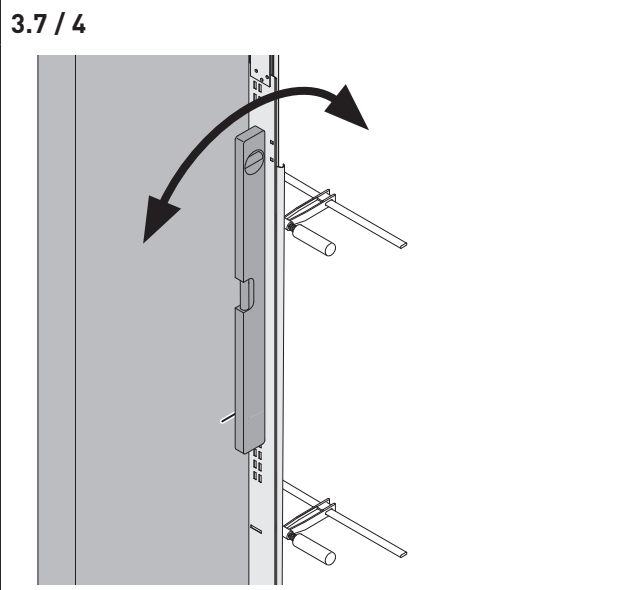

⇒ Check whether the right and left frame are aligned vertically to the door opening.

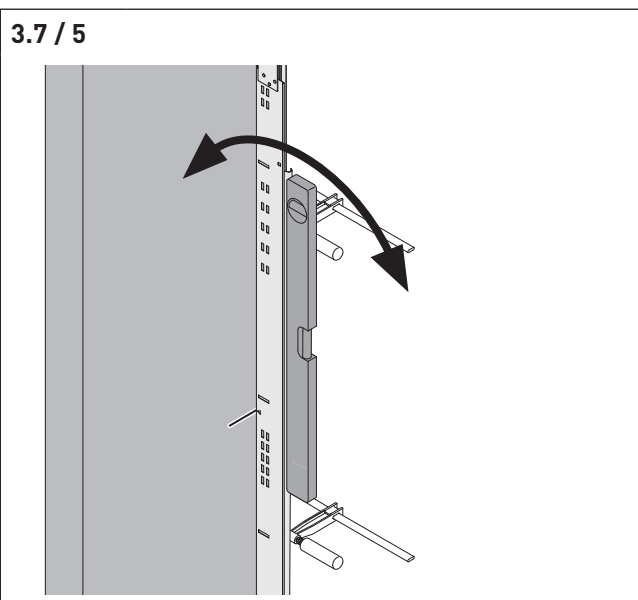

⇒ Check whether the right and left frame are aligned vertically to the masonry. If the frame is not vertical, it must be shimmed.

Functional check

In order to ensure fault-free operation of the door, all indicated adjustments must be made.

3.8 Fastening the frame (installation in front of the reveal)

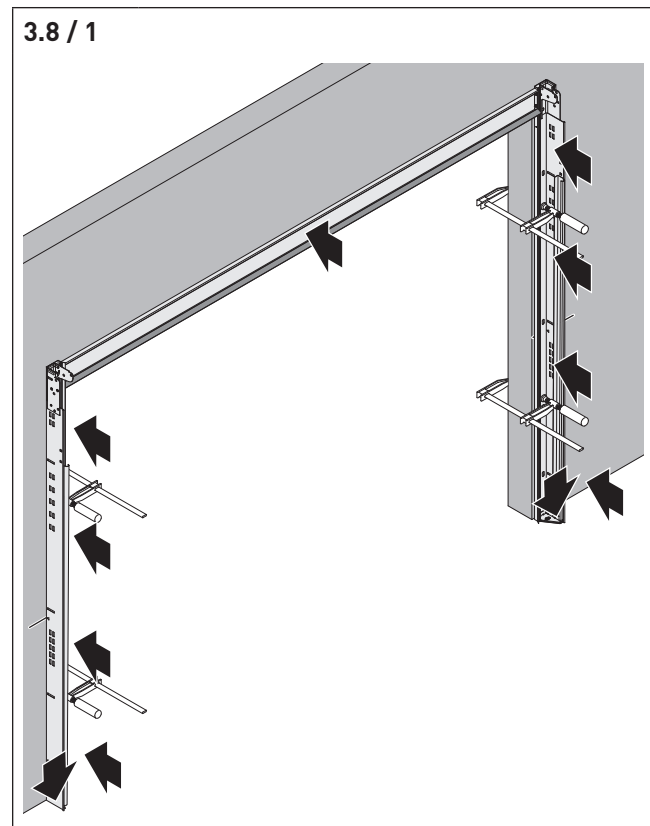

There are **two** possibilities for installing the frame.

Installation variant 1 (installation inside)

⇒ If there is **adequate reveal** available behind the frame, fasten the frame **through the pre-punched holes in the frame** (Fig. "3.8.1 / 1" to "3.8.1 / 4").

Installation variant 2 (installation outside)

⇒ If there is **not adequate reveal** behind the frame, fasten the frame on with the assembly brackets **to the right and left of the frame** (Fig. "3.8.2 / 1" to "3.8.2 / 6").

3.8.1 Installation variant 1 (installation inside)

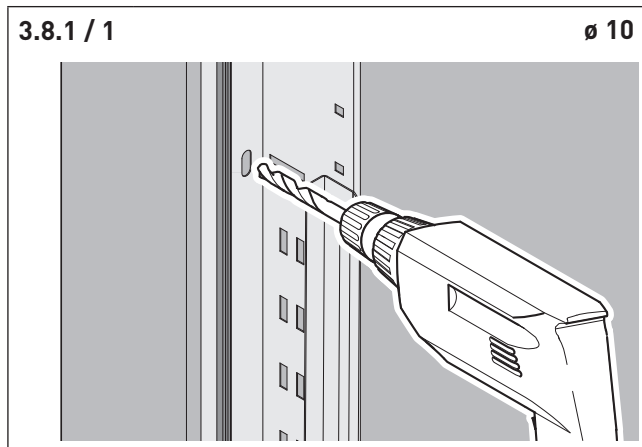

⇒ Drill holes into the frame through the aforementioned holes to a minimum depth of 60 mm in the masonry.

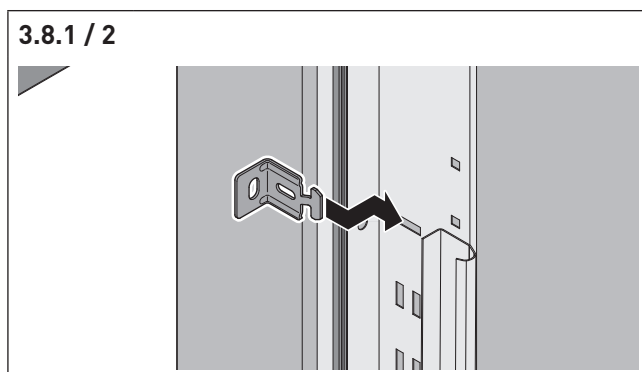

⇒ Use the supplied assembly brackets.

NOTE!

The expanding direction of the anchor must be vertical!

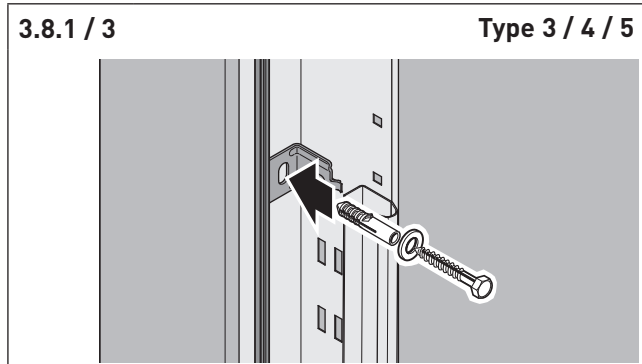

⇒ Screw in the anchors.
 ⇒ Fasten the frame on with the assembly brackets.

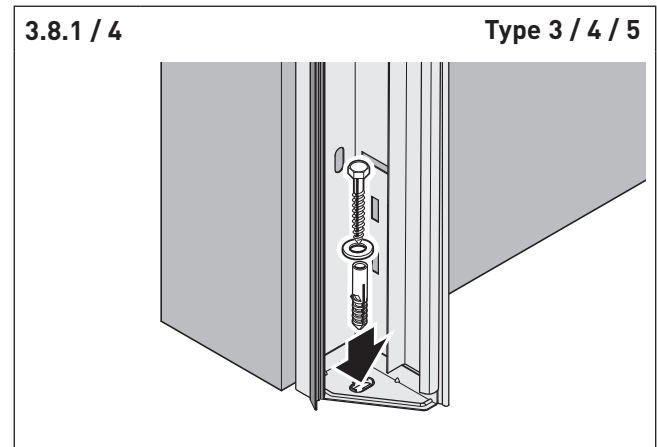

⇒ Fasten the frame to the floor.

3.8.2 Installation variant 2 (installation outside)

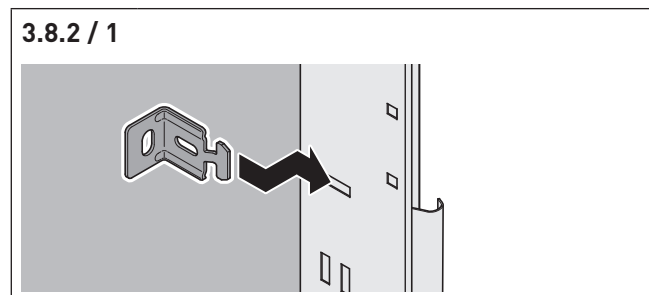

⇒ Hold the assembly brackets next to the frame at the height of the pre-punched holes in the frame.

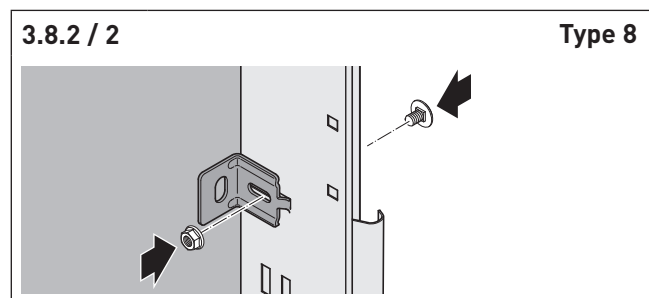

⇒ Fasten the mounted brackets on the sides of the frame with one screw each.

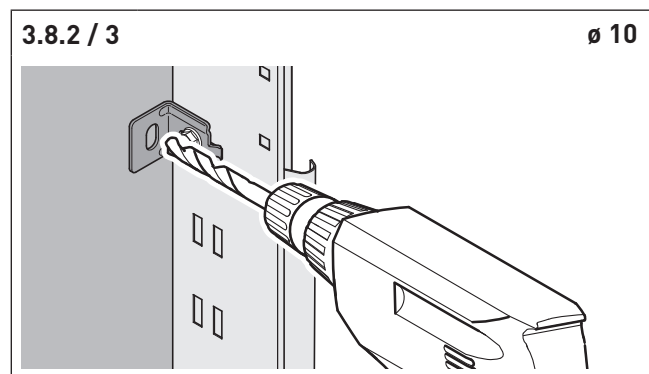

⇒ Drill a hole through the assembly brackets into the masonry next to the frame to a minimum depth of 60 mm.

NOTE!

The expanding direction of the anchor must be vertical!

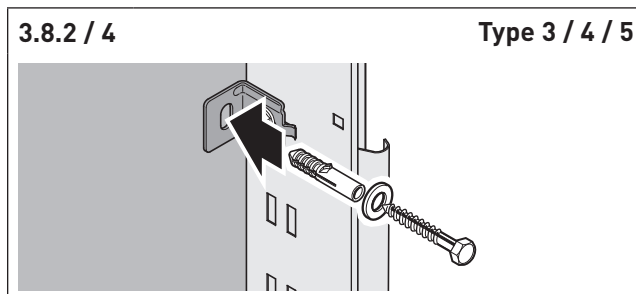

- ⇒ Screw in the anchors.
- ⇒ Position the assembly brackets on the frame and screw the assembly brackets into the masonry.
- ⇒ Fasten the mounted brackets on the sides of the frame with one screw each.

NOTE!

The frame bracket must be fastened to the structure **1x!**

The fastening takes place independently of whether you have mounted the assembly brackets in or next to the frame.

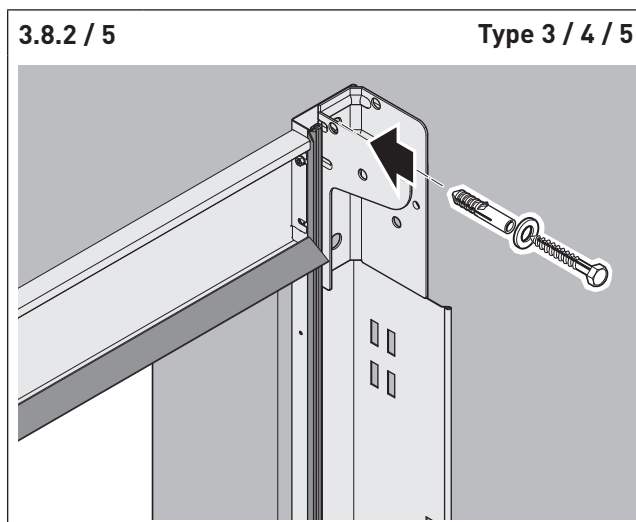

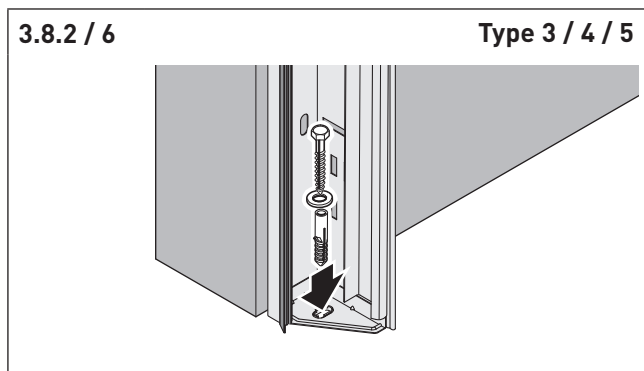

⇒ Fasten the frame to the floor.

3.9 Installing the lintel casing

There are **two** possibilities for installing the lintel casing.

Installation variant 1 (through the lintel casing)

⇒ If there is **adequate reveal** behind the lintel casing:
Fasten directly through the lintel casing
(Fig. "3.9.1 / 1" to "3.9.1 / 2").

Installation variant 2 (with lintel casing holder)

⇒ If there is **not adequate reveal** behind the lintel casing:
Fasten the lintel casing onto the lintel casing holder
(Fig. "3.9.2 / 1").

3.9.1 Installation variant 1 (through the lintel casing)

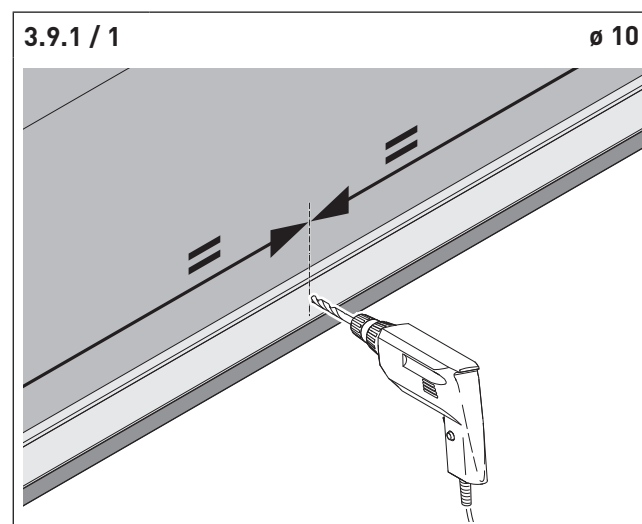

One screw connection in the lintel casing is adequate for a maximum door width of 3 m.

With a door with greater than 3 m, you require two screw connections.

In the process, align the two screw connections over the length of the lintel casing.

⇒ Drill through the centre of the lintel casing to a minimum depth of 60 mm in the masonry.

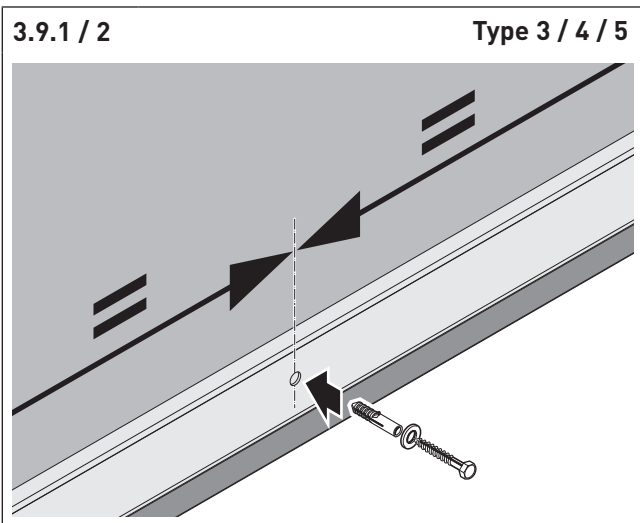

⇒ Fasten the lintel casing into the masonry.

3.9.2 Installation variant 2 (with lintel casing holder)

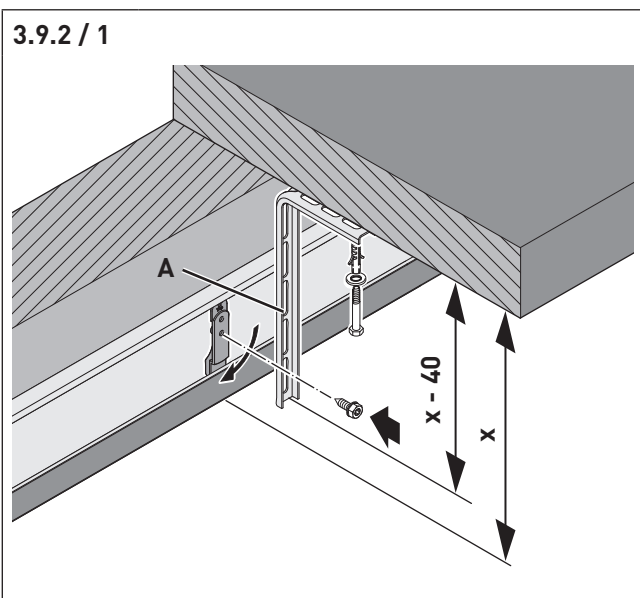

One screw connection on the lintel casing is adequate for a maximum door width of 3 m.

With a door with greater than 3 m, you require two screw connections.

In the process, align the two screw connections over the length of the lintel casing.

⇒ Install the lintel casing onto the lintel casing holder (A).

3.10 Assembly of the guide rails on the frame

3.10.1 Preparation of the upper guide rails

The following illustrations show the installation on right inner side.

They must be implemented inversely on the left inner side.

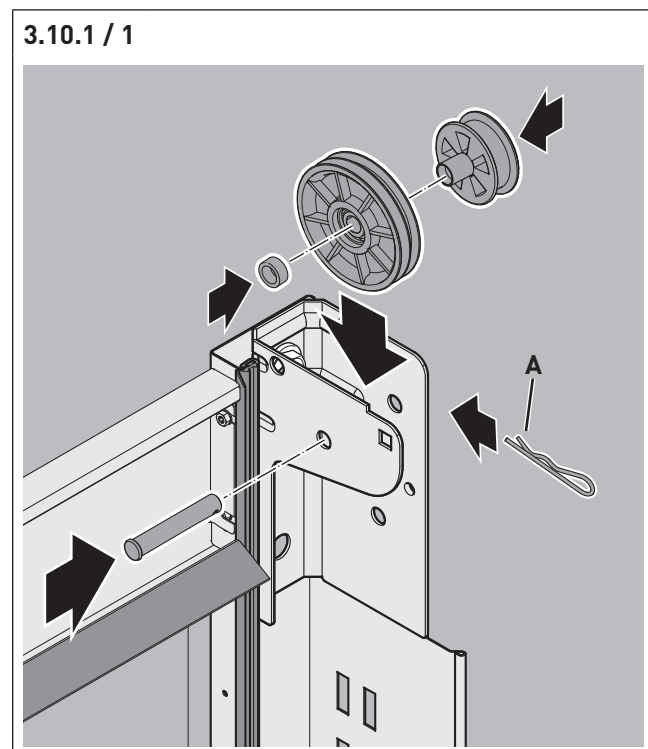

⇒ Insert the rope pulley, the spacer ring and the support pulley together with the right and left bolts into the frame console.

⇒ Secure the bolt with the spring connector (A).

3.10.2 Fastening the upper guide rails

NOTE!

When fastening, the screw must be inserted into the curved rail from inside. The corresponding is positioned on the outside on the curved rail. Otherwise, the screw connection blocks the later door run.

3.10.2 / 1

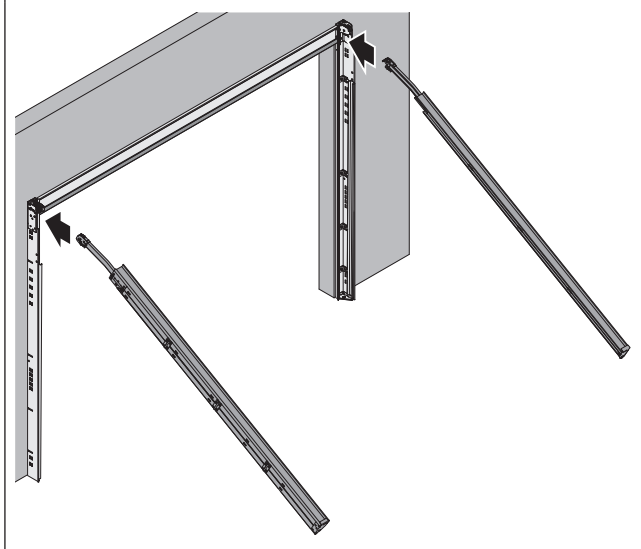

3.10.2 / 2

Type 6

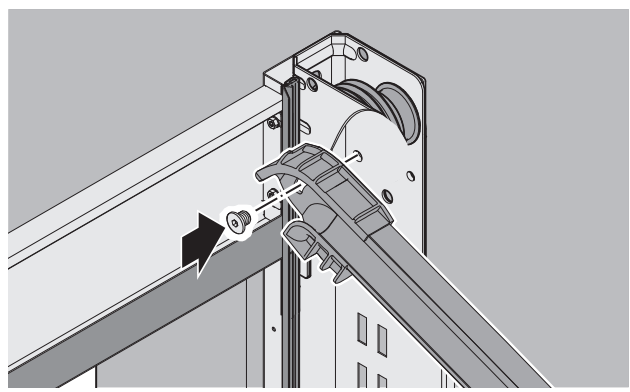

- ⇒ Fasten the left and right plastic arches with one screw each (M8x8 or Torx T25) on the side of the frame consoles.
- ⇒ Only tighten the screw slightly so that the frame can be aligned horizontally.
- ☑ The plastic curved rail must engage in the hole of the bracket. The correct connection and function as a pivoting point can only be guaranteed in this manner.

3.10.3 Fastening the upper cross strut

3.10.3 / 1

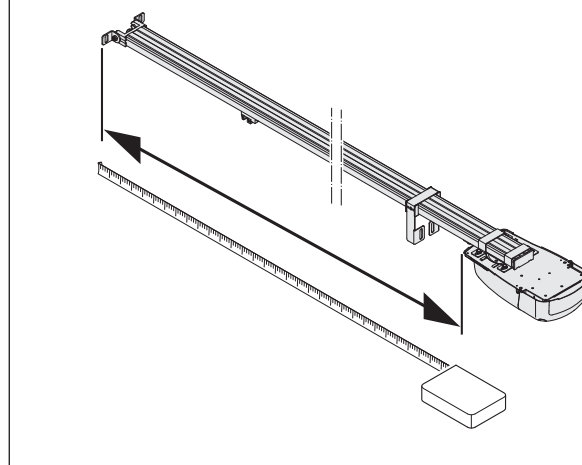

- ⇒ Measure the drive rail of the lintel connector to the drive head.

3.10.3 / 2

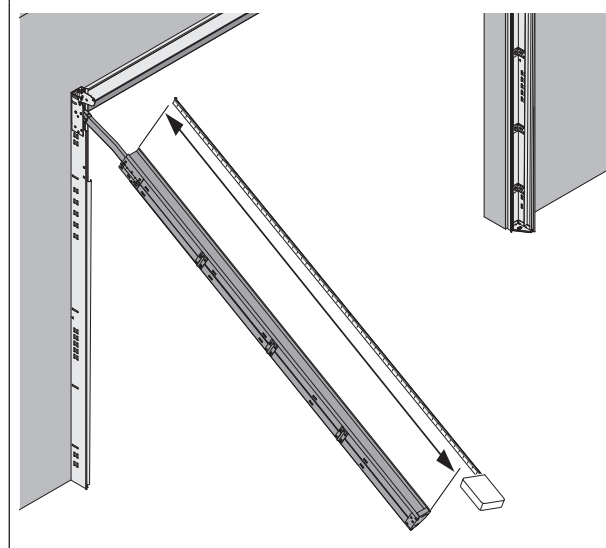

- ⇒ Measure the spring channel.

Drive rail measurement \geq Spring channel measurement + 390 =

Fastening of the cross strut on the rear side.

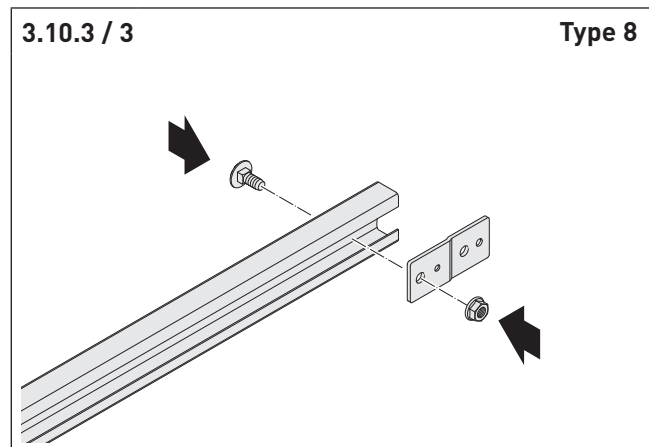

⇒ Fasten the cross strut connecting lugs on the ends of the cross strut on both sides. For this purpose, insert the pin of the connecting lug into the small hole on the cross strut.

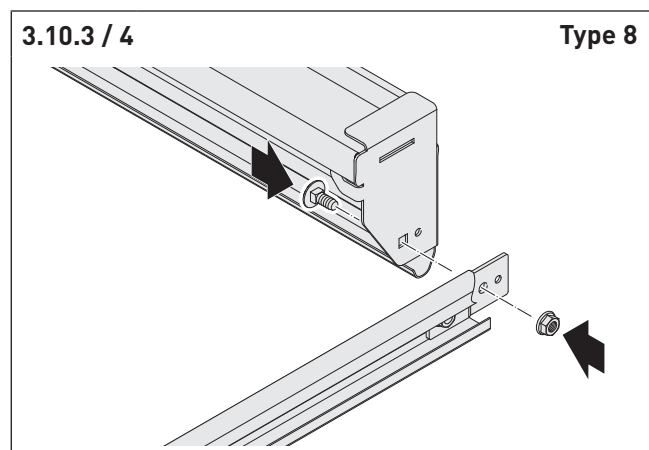

⇒ Fasten the cross strut to the end caps of the spring channel.

Drive rail measurement \leq Spring channel measurement + 390 =

Fastening of the cross strut on the next individual square hole in the lower rail, at which point the distance to the door is shorter than the measurement of the drive rail.

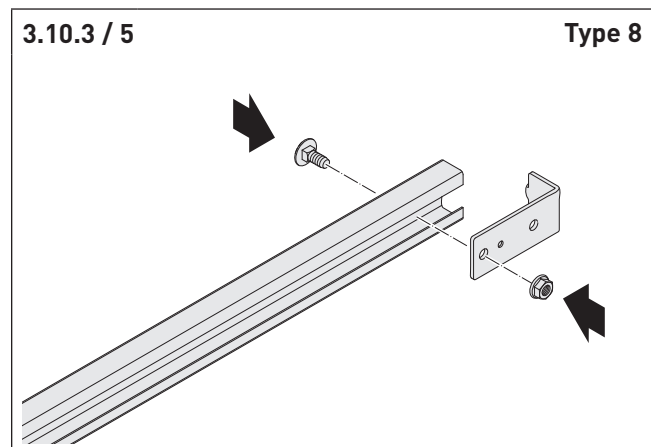

⇒ Install the connecting bracket on both sides of the cross strut.

NOTE!

The cross strut must not be installed further forward; otherwise, the path of travel of the door is blocked.

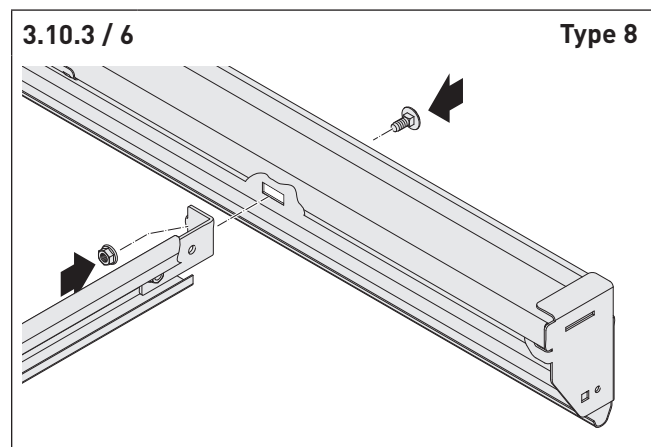

⇒ Fasten the cross strut at the rear-most fastening possibility in the lower guide rail.

3.11 Assembling the double and triple spring package

NOTE!

The two outer spring brackets must be installed outward insofar as possible.

3.11 / 1

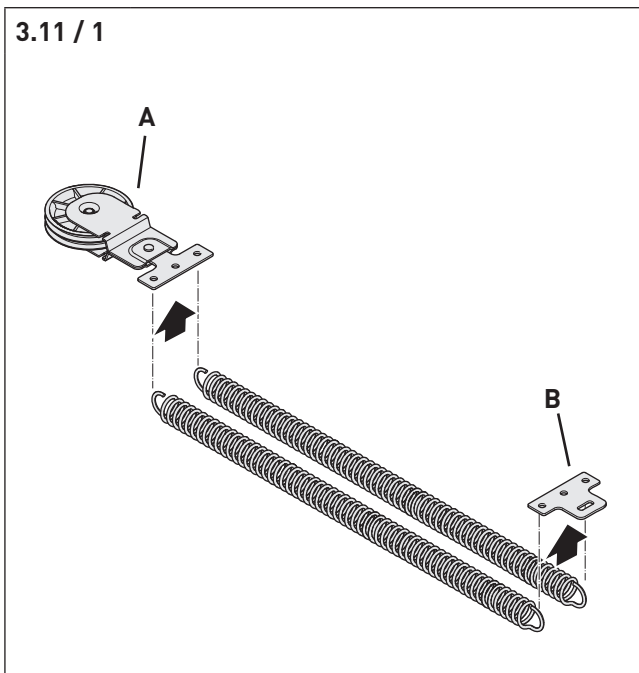

- ⇒ Mount the side roller bracket (A) on the springs.
- ⇒ Mount the side spring bracket (B) on the springs.

3.11 / 2

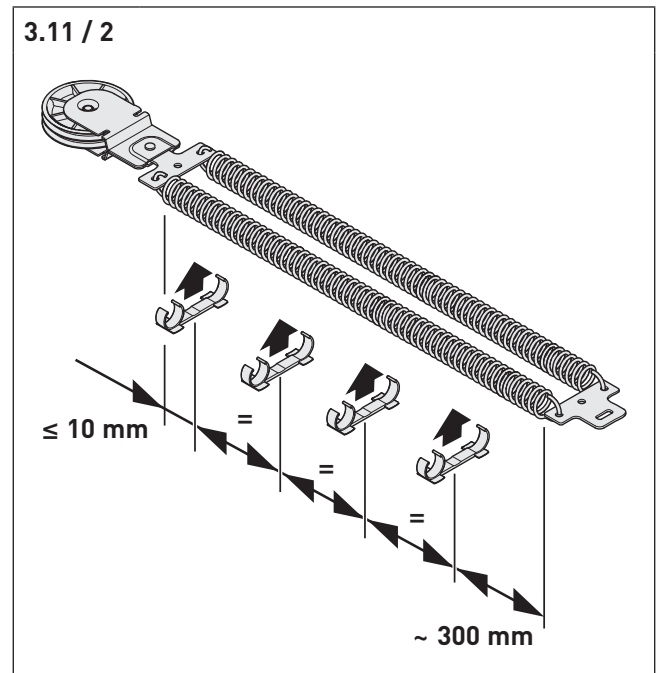

- ⇒ Fit a plastic sliding block onto the springs from below.
- ⇒ Fit a second plastic sliding block onto the other end of the springs from below.
- ⇒ Fit the other plastic sliding blocks from below, spaced evenly on the springs.

3.11 / 3

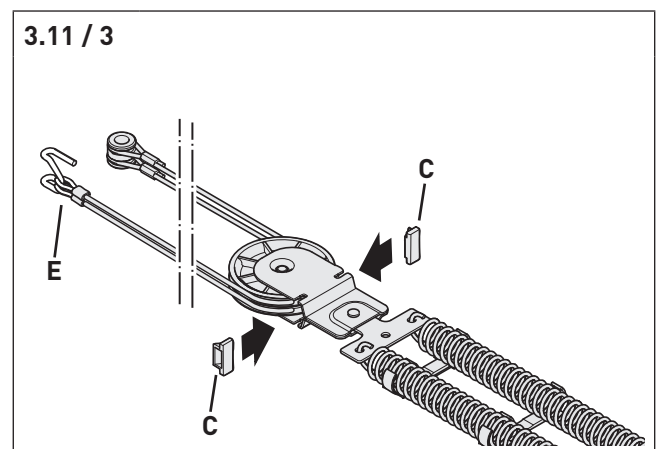

- ⇒ Mount the rope stopper (C).

3.12 Assembling the quadruple spring package

NOTE!

The two outer spring brackets must be installed outward insofar as possible.

3.12 / 1

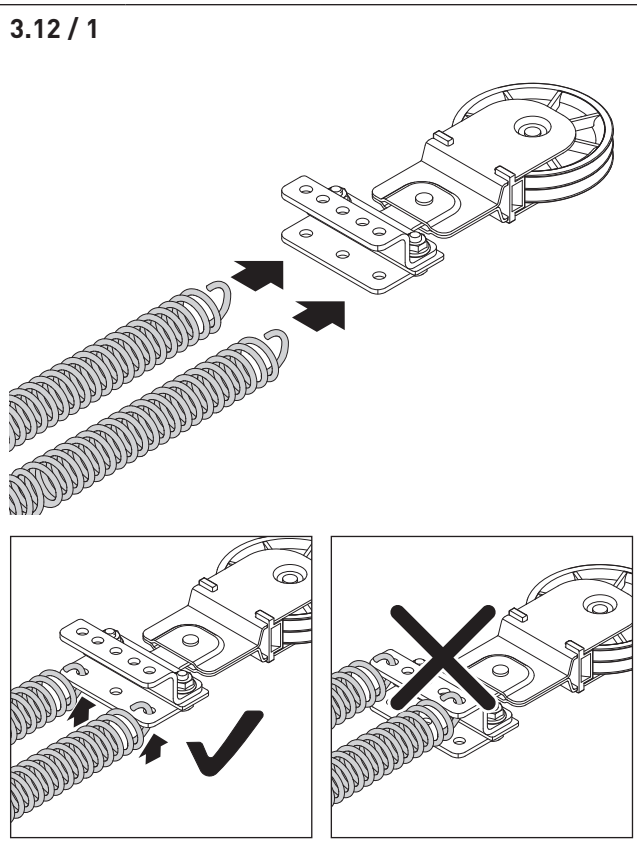

- ⇒ Mount the rope pulley holder onto the springs.
- ⇒ Make sure the springs are correctly hung into the lower mount.

3.12 / 2

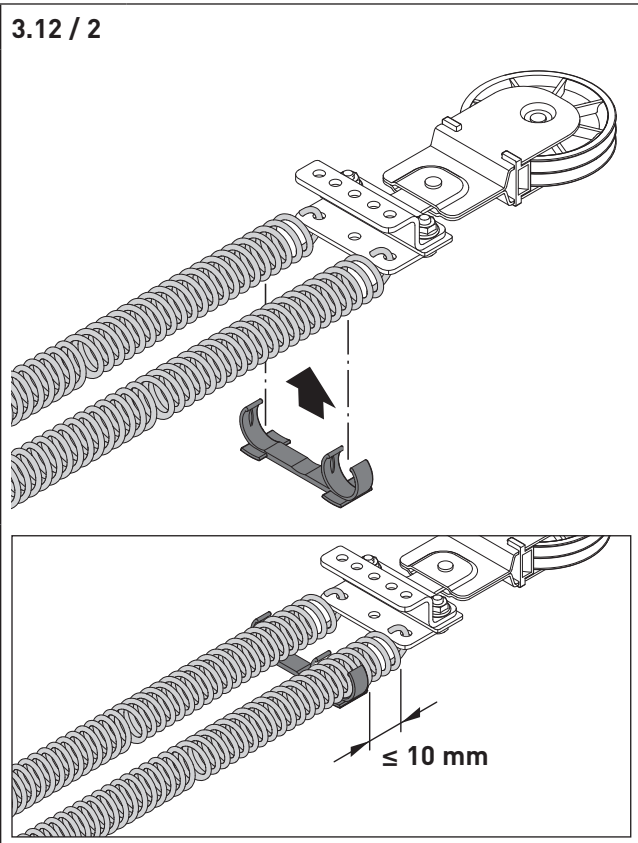

- ⇒ Attach a plastic slide piece onto the springs from below.

3.12 / 3

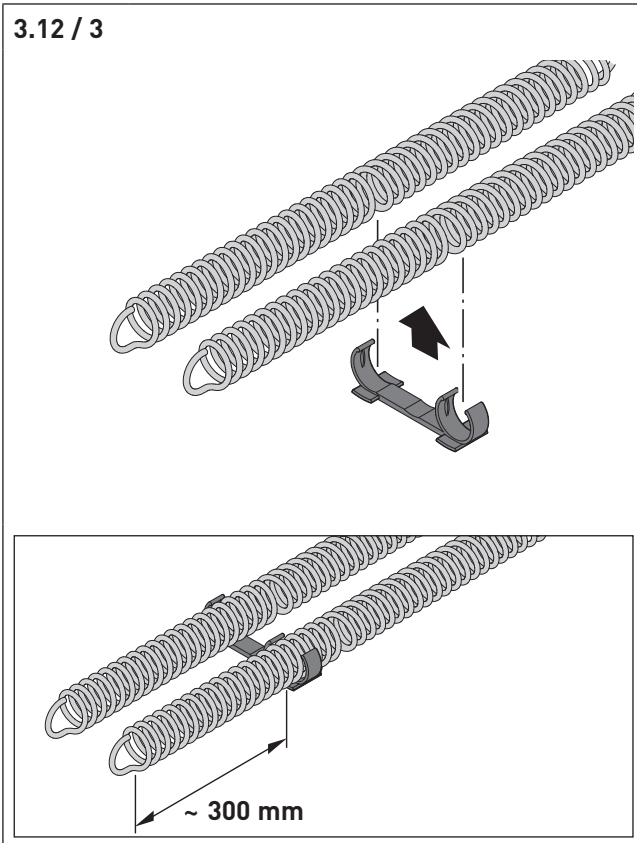

⇒ Attach a second plastic slide piece from below onto the other end of the spring.

3.12 / 4

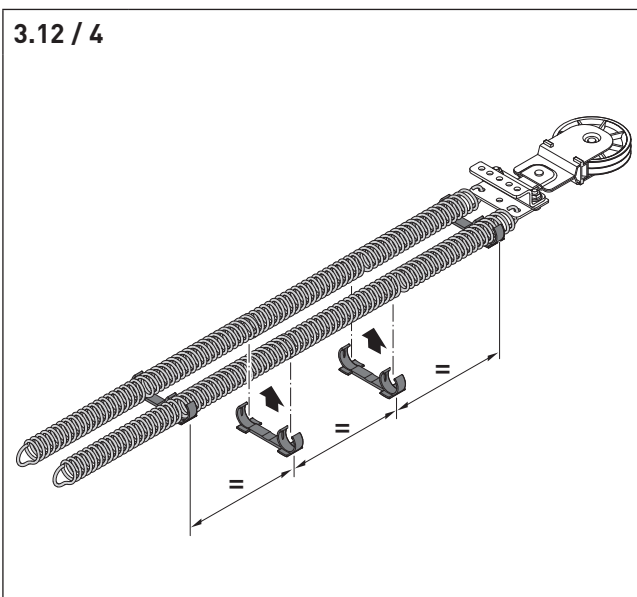

⇒ Attach the other plastic slide pieces onto the springs from below at equal distances.

3.12 / 5

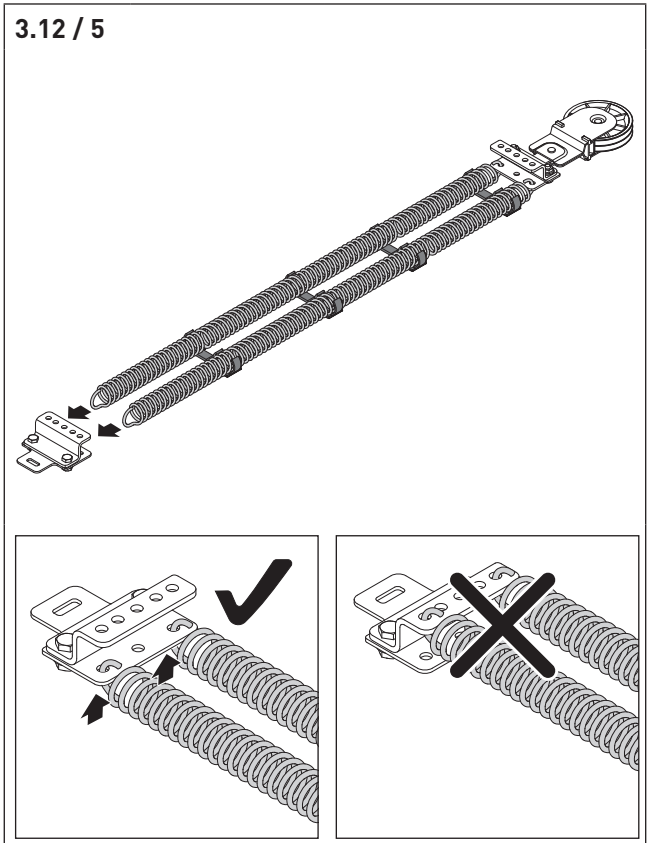

⇒ Mount the spring holder onto the springs.
 ⇒ Make sure the springs are correctly hung into the lower mount.

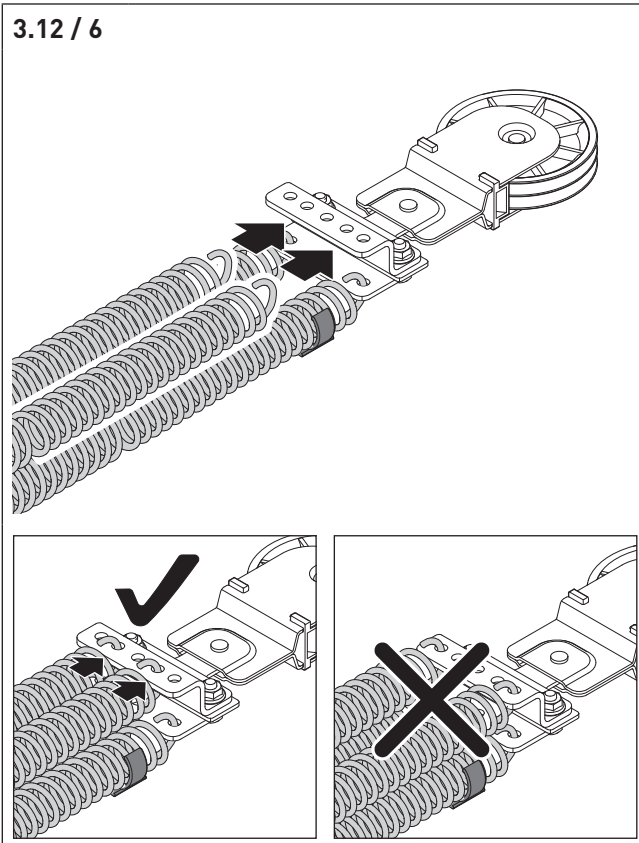

- ⇒ Mount the upper two springs onto the rope pulley.
- ⇒ Make sure the springs are correctly hung into the upper mount.

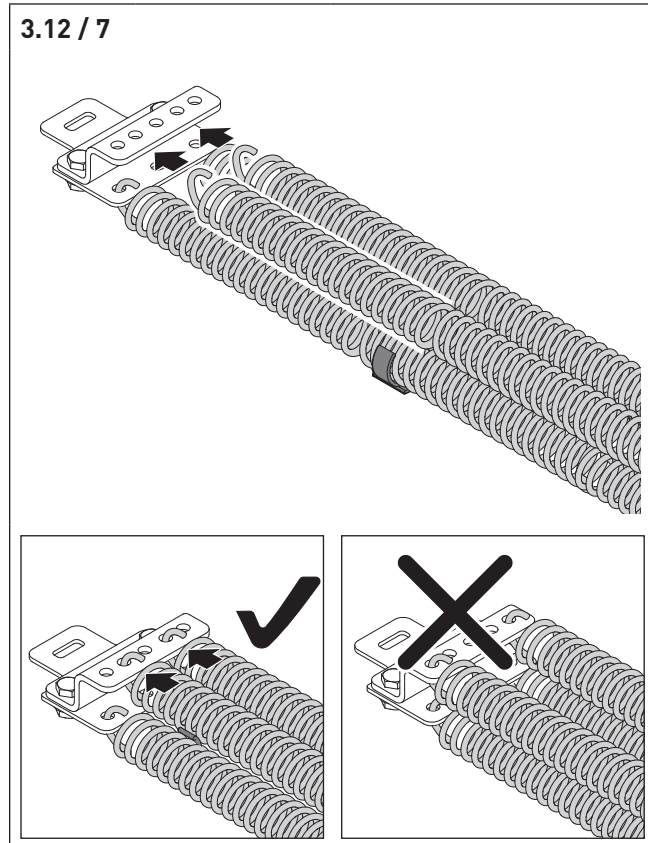

- ⇒ Mount the upper two springs to the spring holder.
- ⇒ Make sure the springs are correctly hung into the upper mount.

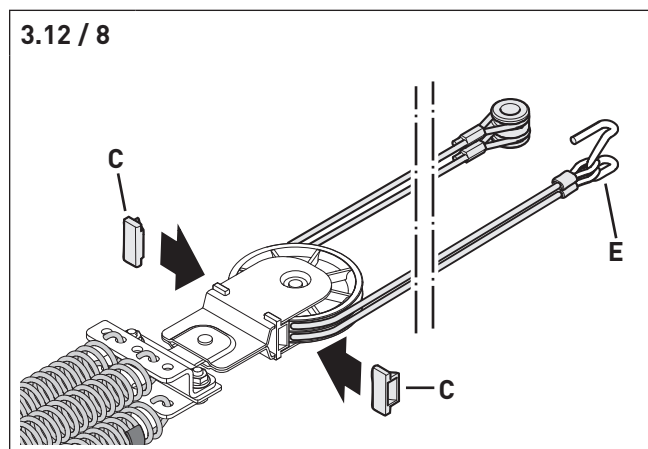

- ⇒ Install the rope stopper (C).

3.13 Installing the spring package into the spring channel

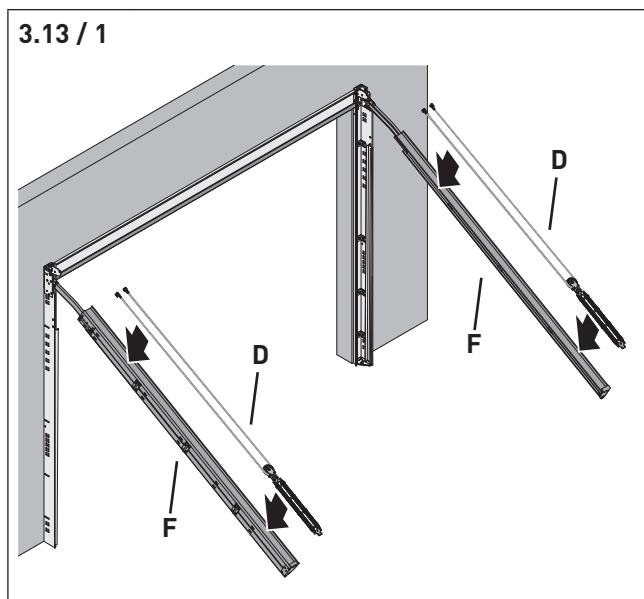

The spring packages (D) are not the same. The right and left spring packages must be assigned to their corresponding gate sides so that the rope bracket (E) points toward the outside of the gate.

- ⇒ Insert the appropriate spring package (D) into the right and left spring channel (F).

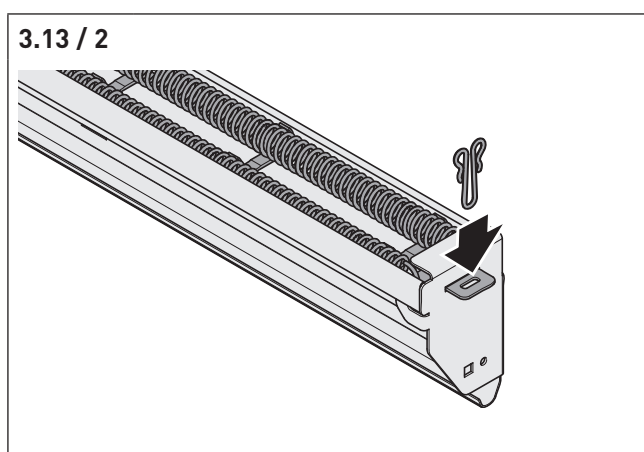

- ⇒ Secure the spring package with the spring plug.

3.14 Assembly of the wire rope

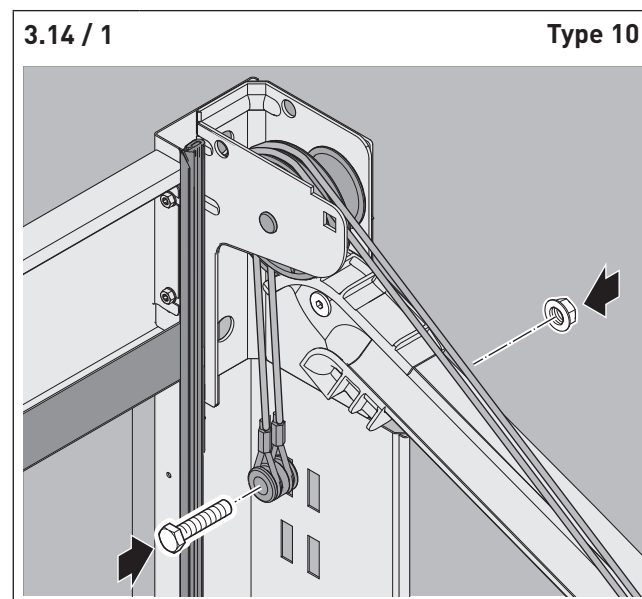

- ⇒ Guide the end of the rope with the rope take-up bushing over the rope pulley.
- ⇒ Pull the rope to one of the first punches, so that the rope is slightly pre-tensed when the horizontal frame is aligned.
- ⇒ Insert the screw through the rope take-up bushing and the punch of the vertical frame.
- ⇒ Secure the screw with the nut.
- ⇒ Make sure the ropes are not twisted.

NOTE!

The cable must run **over** the support roller.
 The cable must not be inserted into the frame bracket next to the curved rail.
 If you do, the action of the resulting forces could damage the frame!

3.14 / 2

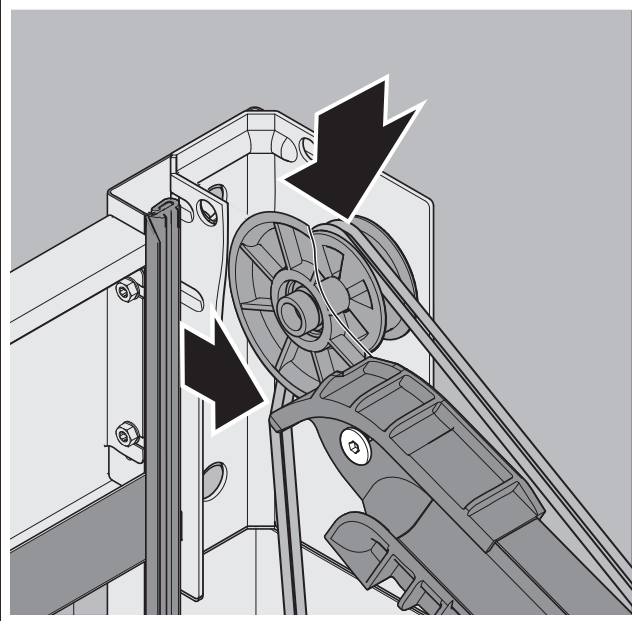

⇒ Route the cable **over** the curved rail and insert the support roller into the frame bracket.

3.14 / 3

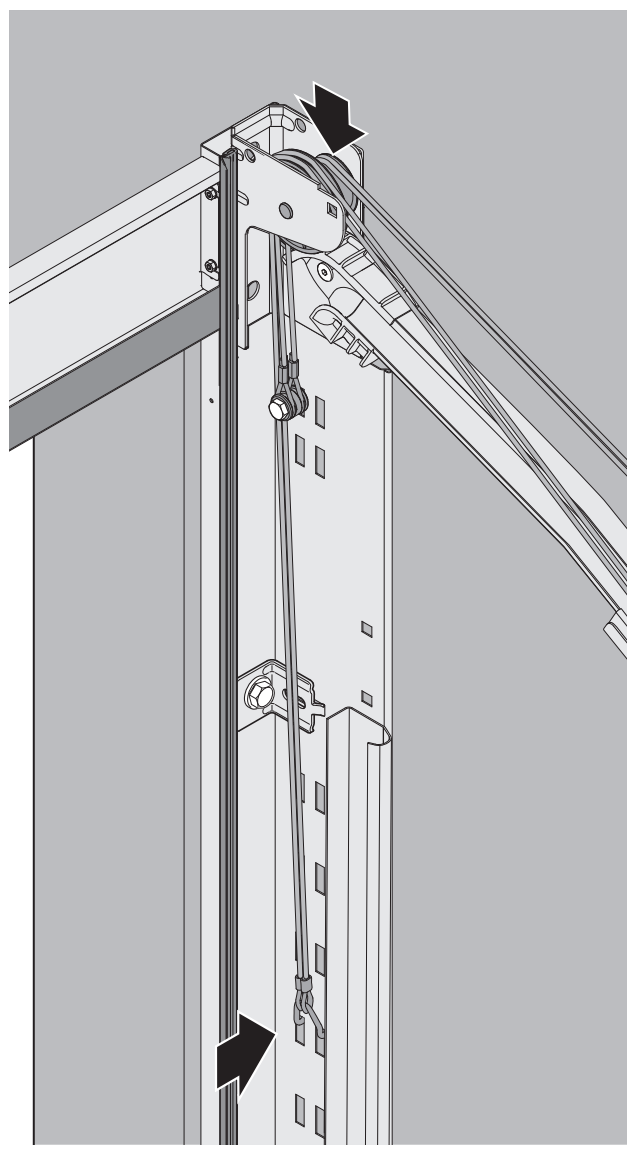

- ⇒ Pull the rope taut.
- ⇒ Tension the rope by another approx. 150 mm.
- ⇒ Hook the rope with the rope bracket into the next punch.
- ☑ The rope end on the left and right side must be hooked into the same punch.

3.14 / 4

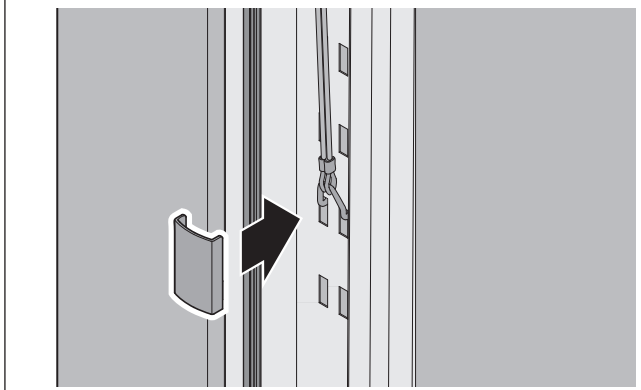

- ⇒ Mount the cover of the rope bracket.
- ⇒ Proceed on the opposite side as described above (Fig. "3.14 / 1" to "3.14 / 4").

3.15 Assembly of the spring channel cover

NOTE!

Prior to covering the spring channel, it must be ensured that

- the ropes are not twisted,
- the ropes run freely,
- the rope ends are mounted,
- the spring channel is free from dust and dirt.

3.15 / 1

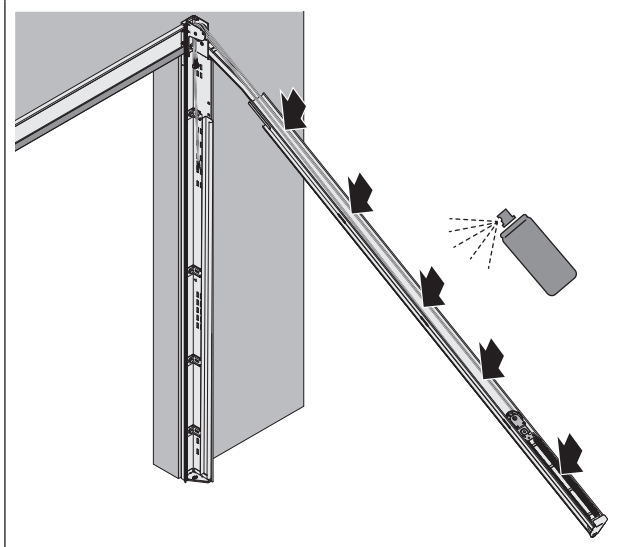

- ⇒ Spray the spring channel with spray grease.

3.15.1 Double and triple spring package

3.15.1 / 1

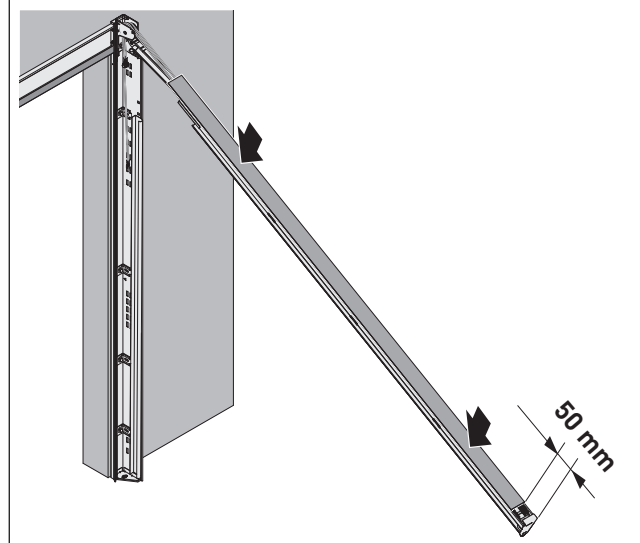

The cover must protrude approx. 50 mm on the door side.

- ⇒ Mount the cover on the spring channel.

3.15.1 / 2

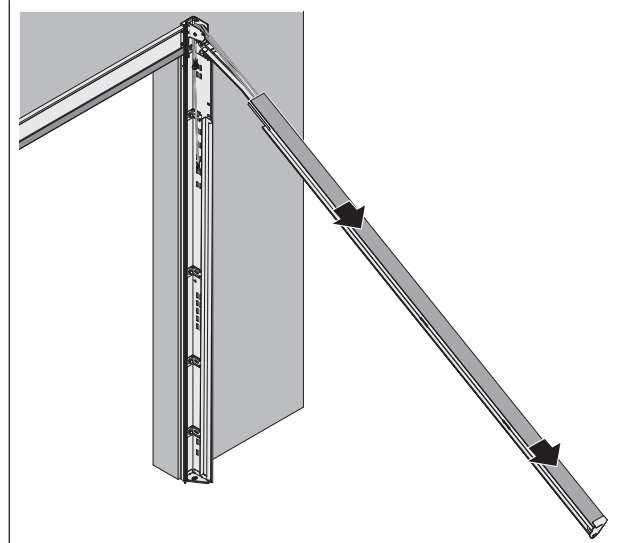

- ⇒ Press the cover on the spring channel until it engages.
The profiling of the cover must engage in the profiling of the spring channel.

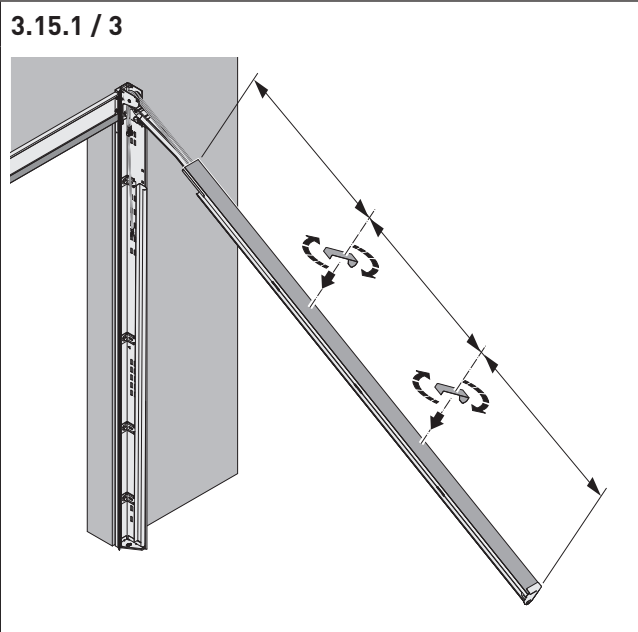

⇒ Secure the cover with the spring channel brackets.

3.15.2 Quadruple spring package

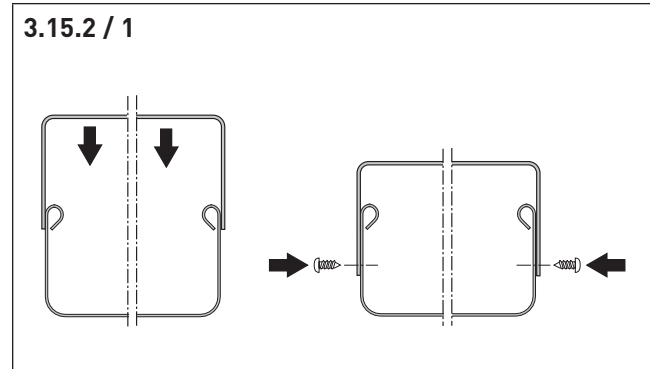

⇒ Screw the cover on the spring channel at the holes provided for this purpose.

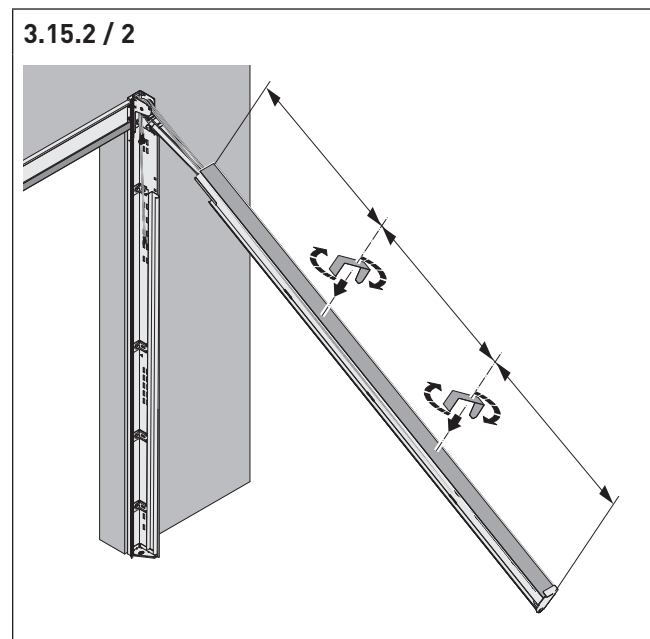

⇒ Secure the cover with the spring channel brackets.

3.16 Assembly of the guide rails on the ceiling

3.16.1 Fastening and aligning the upper guide rails

NOTE!

- The frame packages are not canted when pivoted upwards.
- The side guide rails and cross strut must be exactly horizontal.

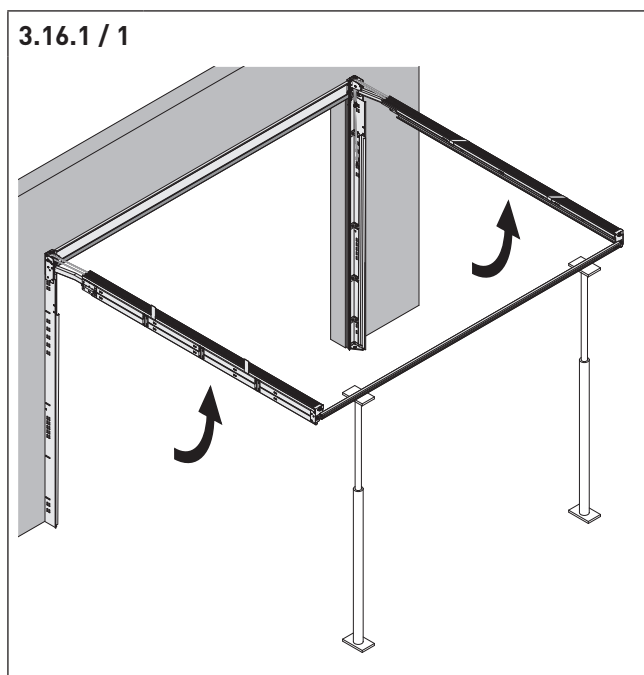

- ⇒ Pivot the fastened frame packages in place and support them.

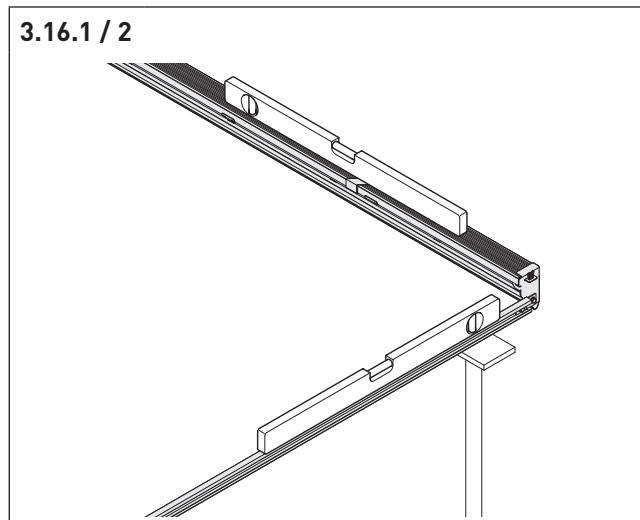

- ⇒ Align the cross strut horizontally.
- ⇒ Align the guide roller horizontally.

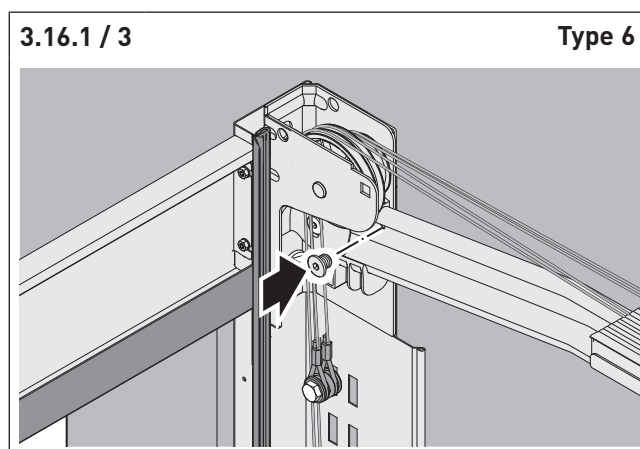

- ⇒ Screw the left and right plastic arcs each with one of the other screws (M8x8 or Torx T25) to the frame.
- ⇒ Tighten the second screw on the plastic curved rail.

3.16.2 Assembly of the lower curved rail

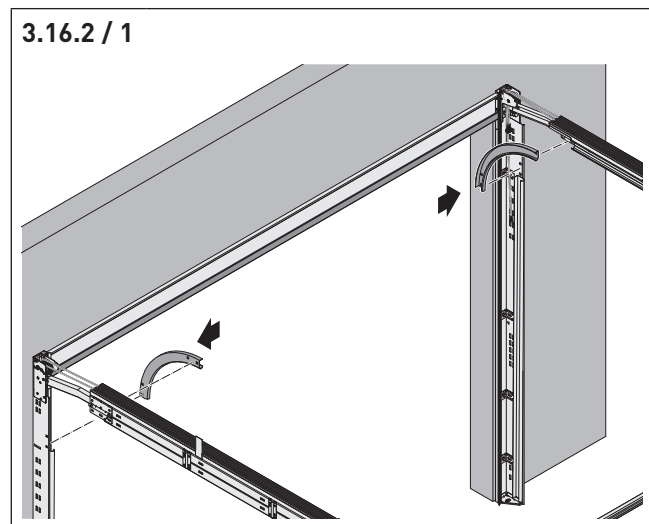

⇒ Adjust the right and left curved rails between the vertical and horizontal rails.

NOTE!

When fastening, the screw must be inserted into the curved rail from inside. The corresponding is positioned on the outside on the curved rail. Otherwise, the screw connection blocks the later door run.

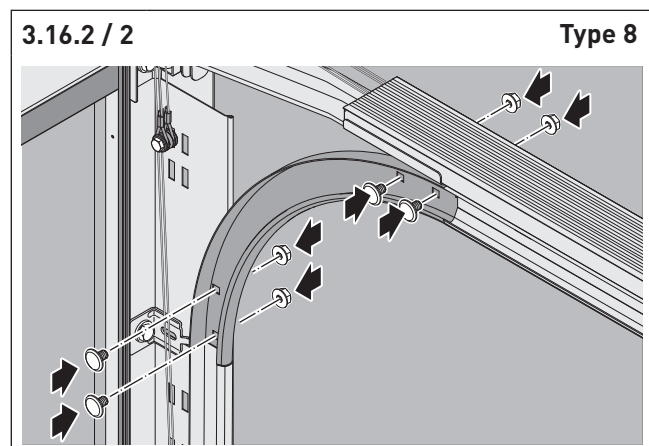

⇒ Fasten the curved rails.
 ⇒ Align the rail end flushly.
 Any protrusions that could impede door operation must be reworked with the pliers.

NOTE!

In order to guarantee correct door travel, the guide rails must be parallel.

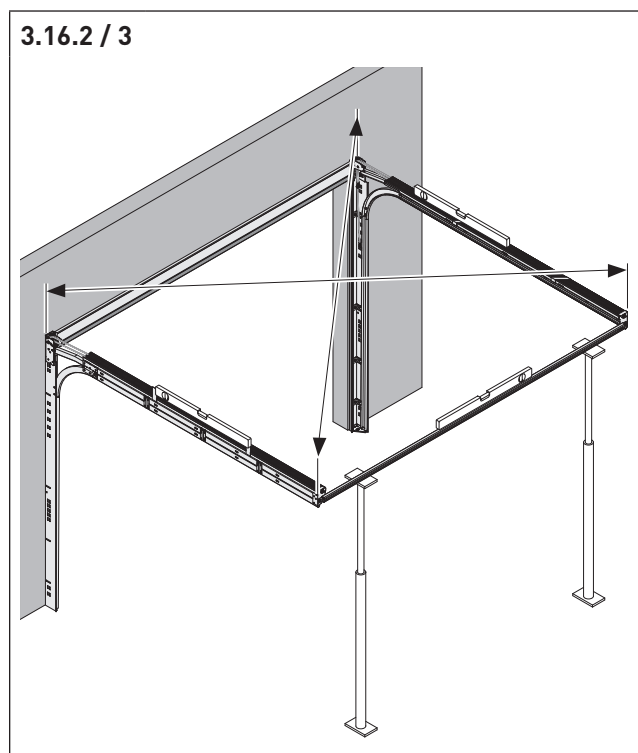

The guide rails are aligned correctly when both diagonals are of equal length. In order to achieve exact measurement results, the same measuring points must be used for each diagonal.

⇒ Measure the diagonals and align the guide rails in parallel.

3.16.3 Assembly of the suspensions on the guide rails

NOTE!

Prior to assembly of the suspension, the door must be aligned as described above (refer to Fig. "3.16.2 / 3").

NOTE!

- The suspensions must be mounted.
- On each side of the frame, two suspensions must be screwed upward.
- It is preferable to use the second and fifth punch patterns of the horizontal guide rails (as seen from the structure outward) to fasten the two suspensions to the ceiling.
- If the **gate width is ≥ 4 m, a third suspension** is needed.
- The third suspension must be fastened in the last punch pattern of the guide rails.

3.16.3 / 1

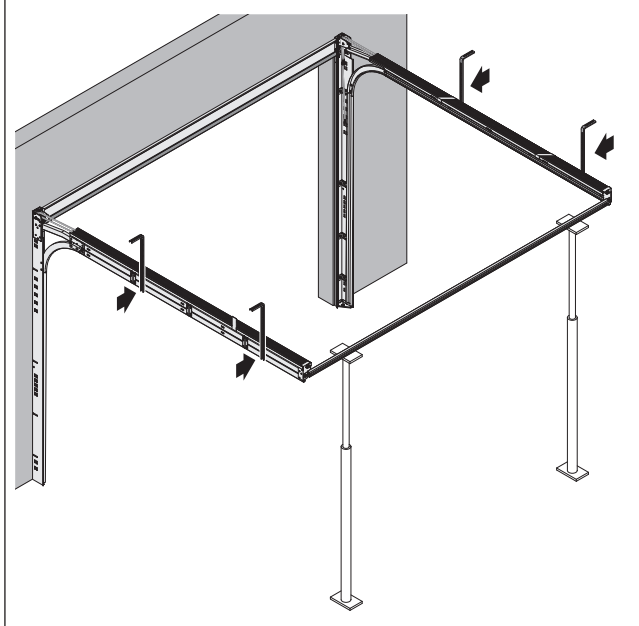

3.16.3 / 2

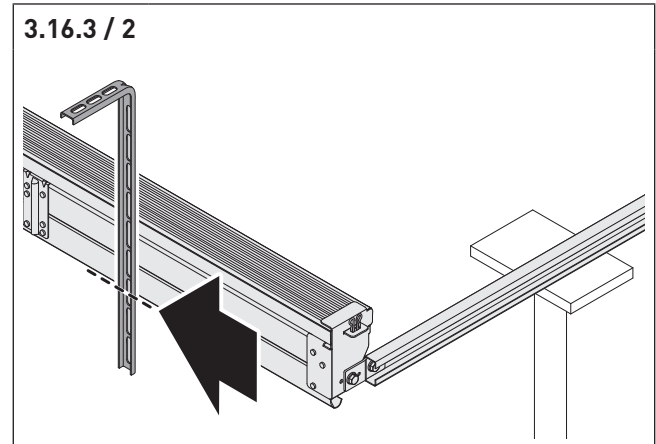

⇒ Attach the suspension in order to define the necessary length.

⇒ Mark any protrusion of the suspension.

In order to assure the greatest stability of the guide rail, the suspension must protrude slightly, however, remain flush with the lower edge of the horizontal frame.

With suspensions that must be rotated inward due to an inadequate lateral stop, the suspension must also be screwed into the wall below the guide rail.

⇒ Cut off any protrusion at the marked point.

NOTE!

Before drilling, it must be ensured that the spring channel is covered.

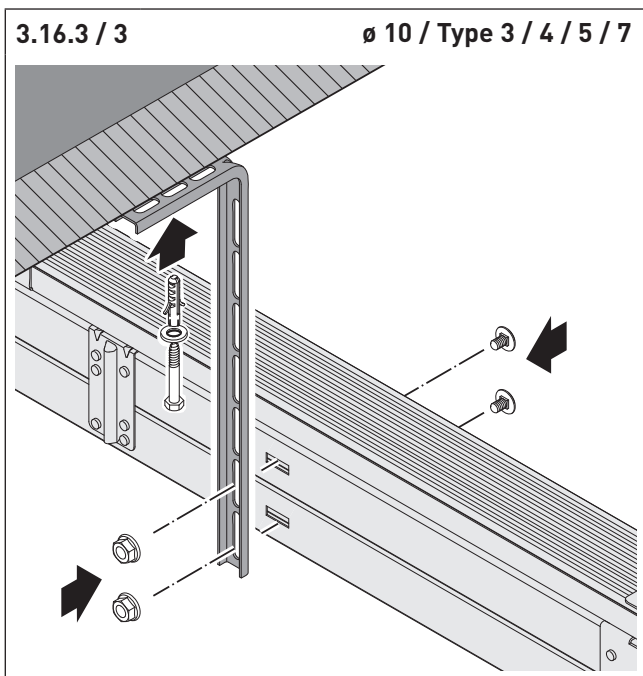

- ⇒ Hold the suspension on the guide rail and mark the drilling point.
- ⇒ Drill to a minimum depth of depth of 60 mm in ceiling.

NOTE!

When fastening, the screws must be inserted into the curved rail from inside.
The corresponding nuts are positioned on the outside on the curved rail.
Otherwise, the screw connection blocks the later door run.

- ⇒ Screw the suspension with two screws on the side of the guide rails.
- ⇒ Insert the anchor in the pre-drilled hole and fasten the suspension on the ceiling.
- ⇒ Assemble all additional suspensions as described (Fig. "3.16.3 / 1" to "3.16.3 / 3").

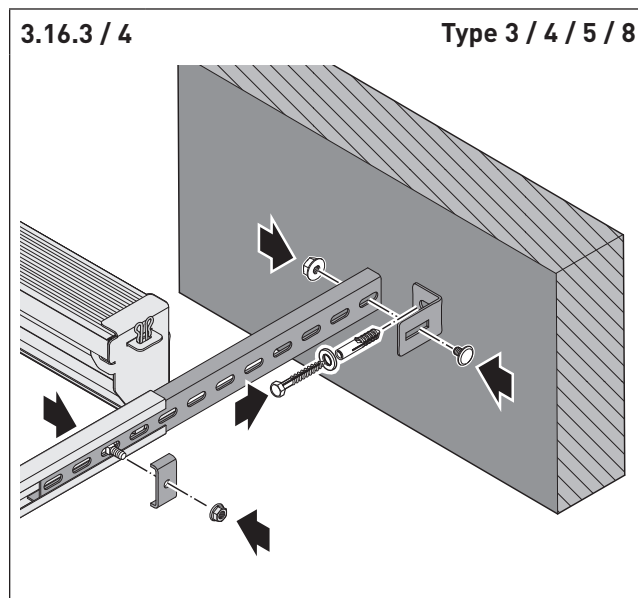

- In order to stabilise the door on the sides, it is necessary to a wall strut.
- The distance of the holes must be as large as possible.
- ⇒ Fasten the mounting bracket to the telescopic strut.
- ⇒ Adjust the distance to the wall with the telescopic function.
- ⇒ Fasten the mounting bracket together with the wall.

3.17 Assembly of the door sections

3.17.1 Preparation of the lower door section

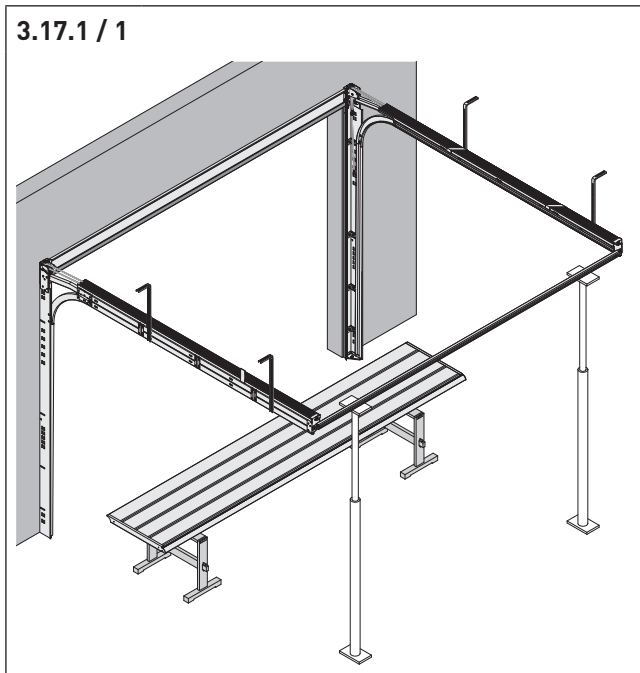

3.17.1 / 1

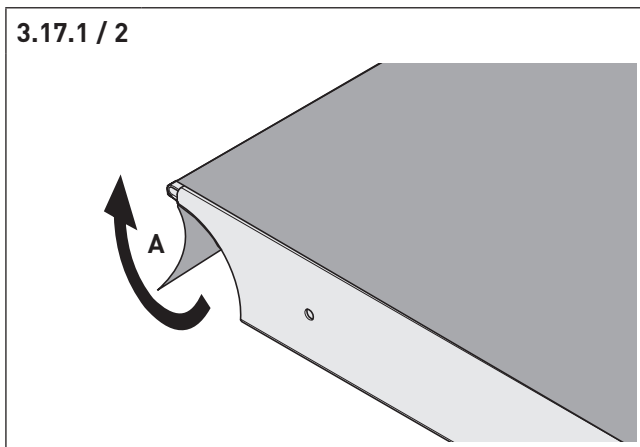

3.17.1 / 2

All sectional door panels must be provided with protective film. These can be in the area of the rounding (A) depending on the panel height.

⇒ Remove the protective film from the rounding area of the panels before mounting them.

Leave the protective film on the outside of the panel until the door assembly is completed.

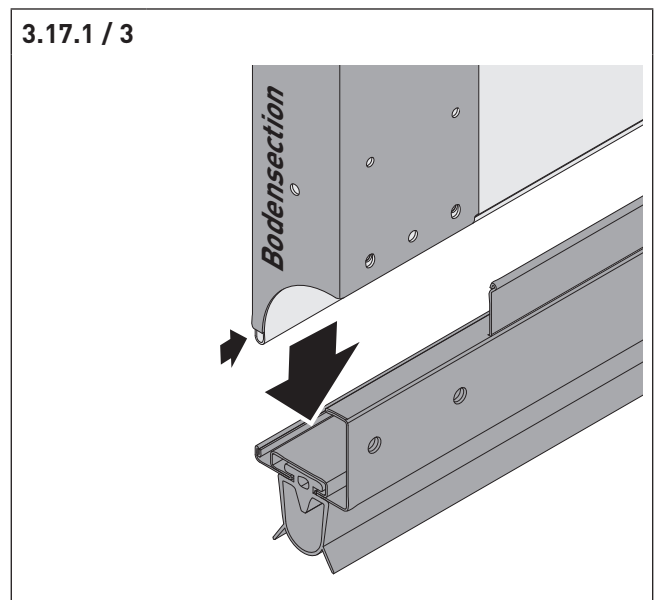

3.17.1 / 3

The lower door section of the side sticker is recognisable by the "bottom section" label and the shortened end caps.

- ⇒ Prepare the lower door section, if necessary, on supports.
- ⇒ Fit the bottom end profile on the lower door section.

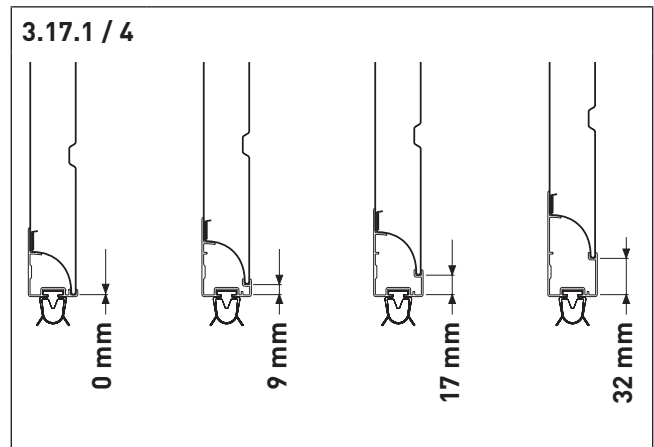

3.17.1 / 4

Four versions of the bottom end profile are available: 0 mm, 9 mm, 17 mm, 32 mm

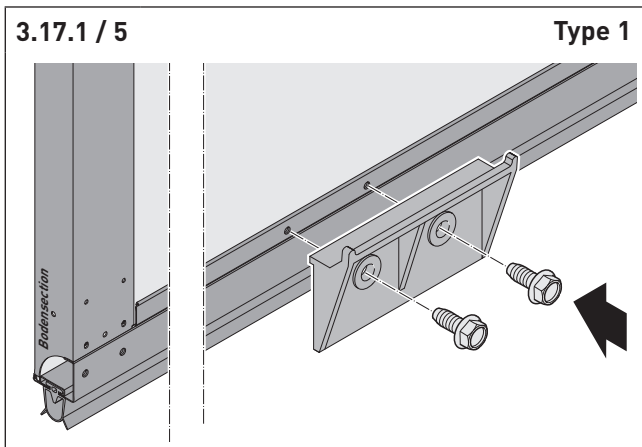

- ⇒ Fasten the bottom end profile in the centre of the bottom section.
- ⇒ Fasten the optional handle on manually operated doors.
- ⇒ Adjust the bottom section in the centre of the door opening.

Double and triple spring system

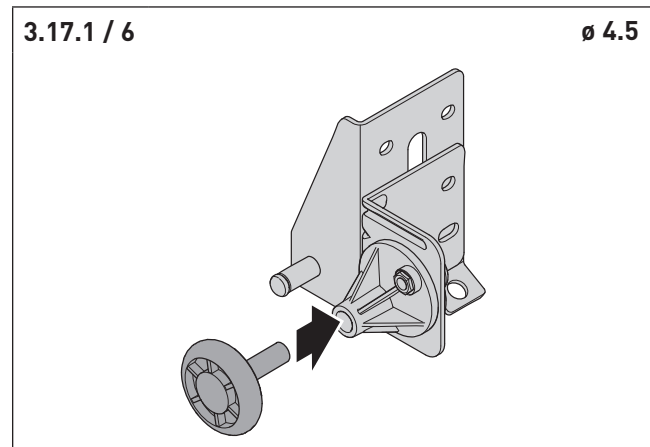

- ⇒ Fit the track roller in the bottom bracket (only double and triple spring system).
- ⇒ Slide the track roller with the bottom bracket into the guide rail (only double and triple spring system).

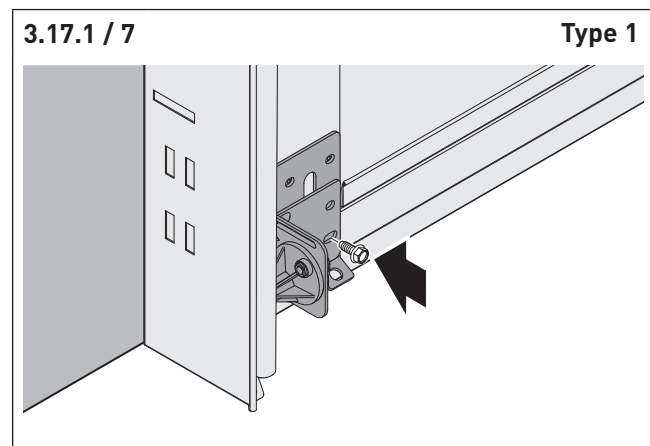

- ⇒ Fasten the lower screw of the bottom bracket together with the lower door section.

Additional holes must be made in the side steel end caps for the screw connection of the bottom bracket with some bottom end profiles.

NOTE!

The door leaf must not be drilled
(max. 25 mm depth)!

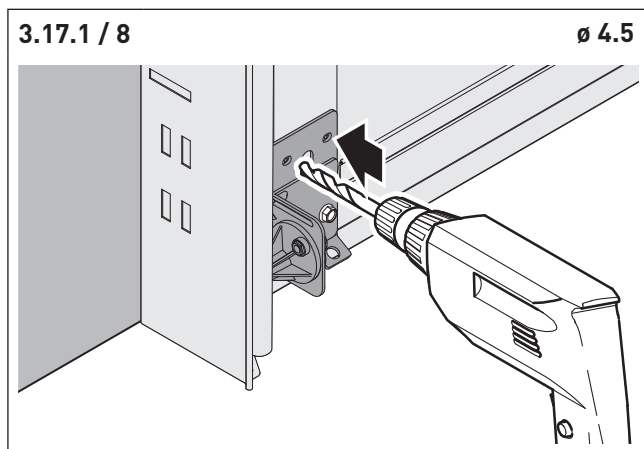

⇒ Drill the missing holes for the screw connection, if necessary.

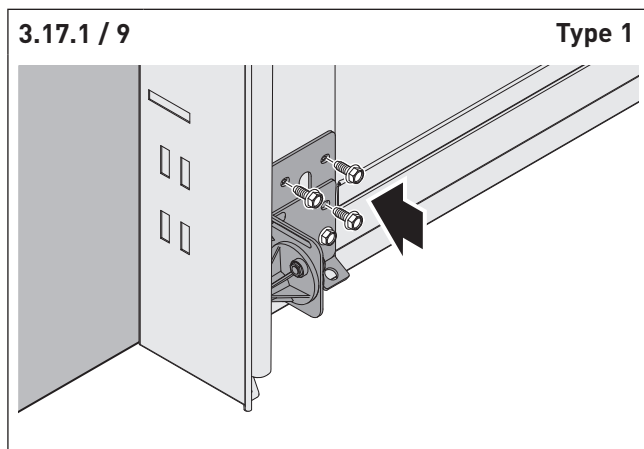

⇒ Fasten the remaining screws of the bottom bracket together with the lower door section.

Quadruple spring system

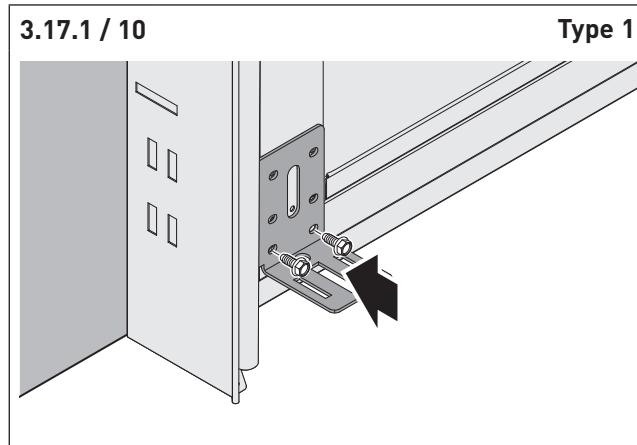

⇒ Fasten the two bottom screws of the bottom bracket together with the lower door section.

Additional holes must be made in the side steel end caps for the screw connection of the bottom bracket with some bottom end profiles.

NOTE!

The door leaf must not be drilled
(max. 25 mm depth)!

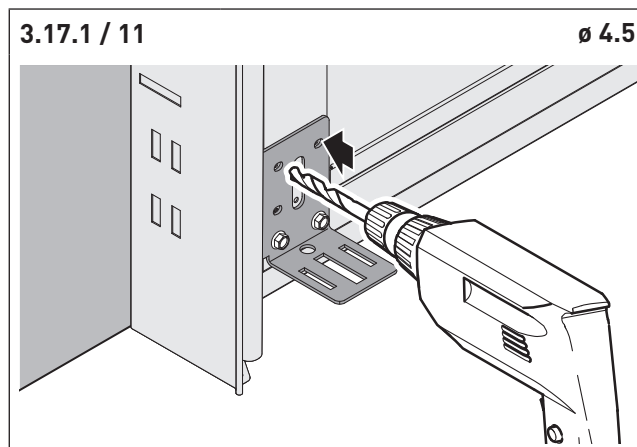

⇒ Drill the missing holes for the screw connection, if necessary.

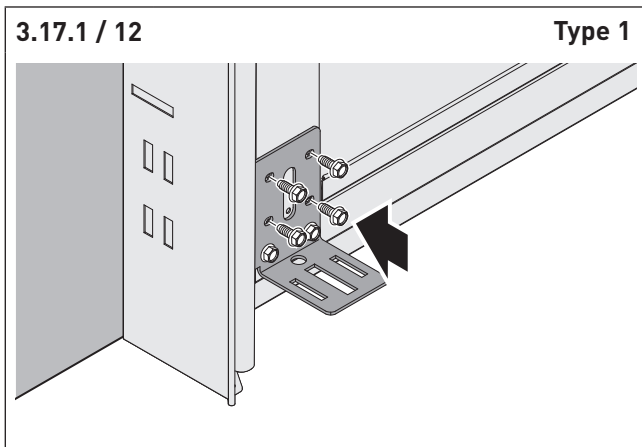

⇒ Fasten the remaining screws of the bottom bracket together with the lower door section.

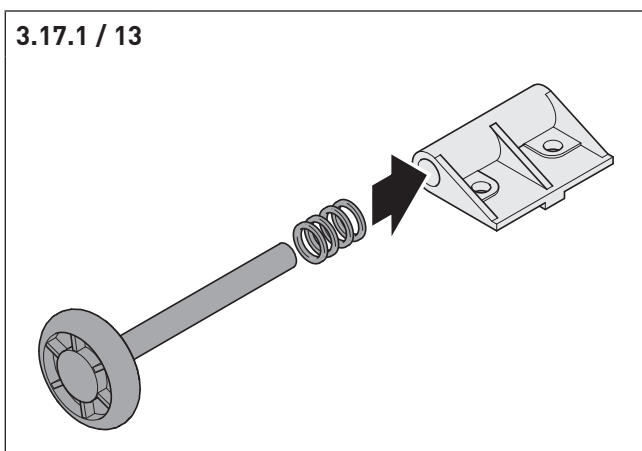

With use of the quadruple spring channel, the door must be aligned centred between the guide rails with the spacer rings (max. 8 pieces).

⇒ Insert the track roller in the roller bracket.

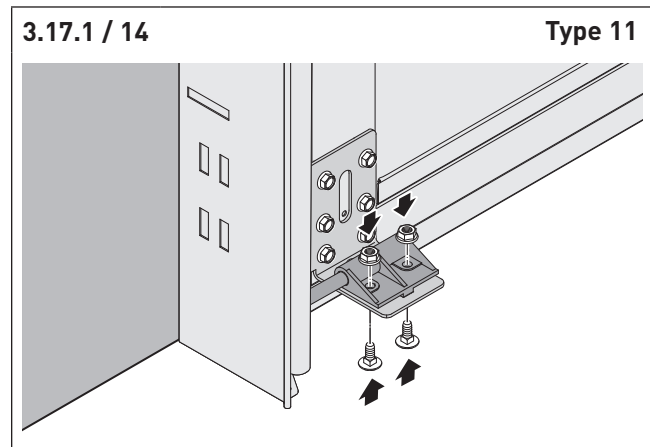

- ⇒ Slide the track roller into the guide rail.
- ⇒ Select the number of spacers so that there is a distance of 2 - 3 mm on both door sides between the track roller and the roller bracket.
- ⇒ Screw the roller bracket onto the bottom bracket.
- ⇒ Perform the steps to mount the bottom bracket on both sides of the bottom section.

All spring systems

NOTE!

In order to relieve the floor end profile, the lower section must be shimmed.

Do not trap the sealing lips on the frame seal between the panel and the frame.

3.17.1 / 15

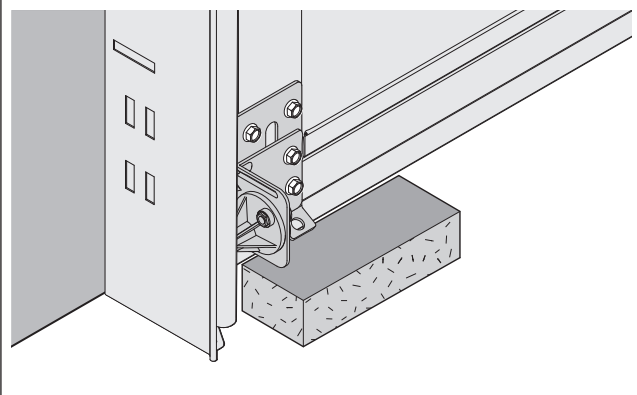

3.17.1 / 16

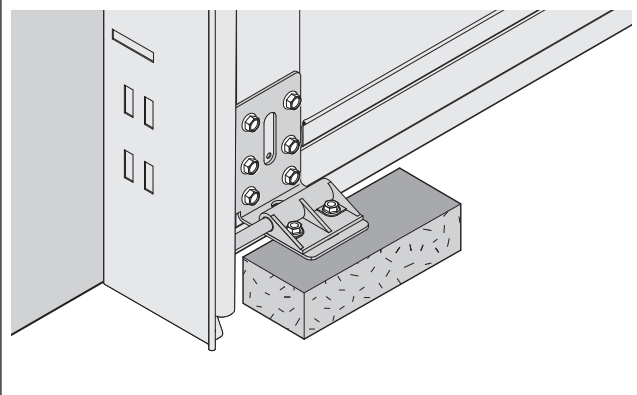

- ⇒ Place wooden blocks under the bottom bracket on both sides:
 - Double and triple spring system (Fig. "3.17.1 / 15")
 - Quadruple spring system (Fig. "3.17.1 / 16")
 - The wooden blocks must be high enough to ensure that the door end profile is not pressed in.
 - The door leaf must be horizontal and at the OFF height after being propped.
 - Gates with a width ≥ 3500 mm must additionally be supported in the middle.
- ⇒ Adjust the track rollers.

3.17.2 Assembly of additional door sections

3.17.2 / 1

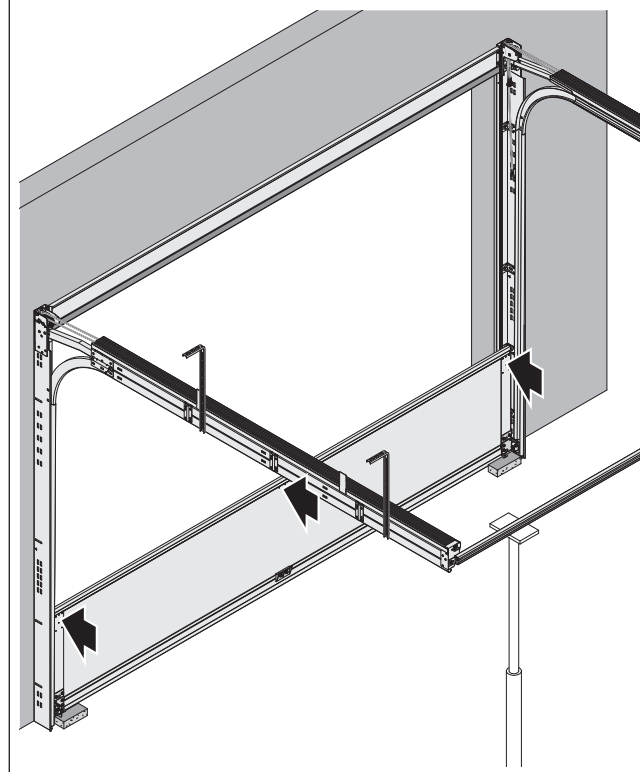

3.17.2 / 2

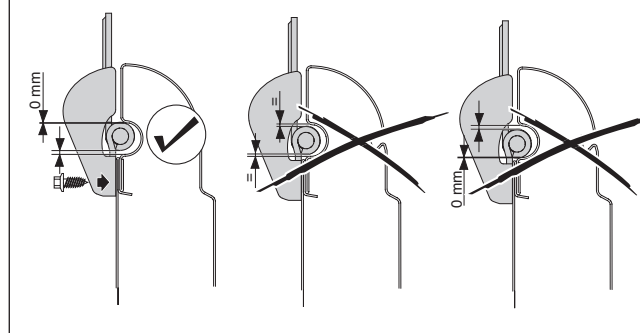

All central and lateral hinges must be screwed on in such a way that the hinge strikes the upper bead edge.

Double and triple spring system

NOTE!

The door leaf must not be drilled
(max. 25 mm depth)!

3.17.2 / 3

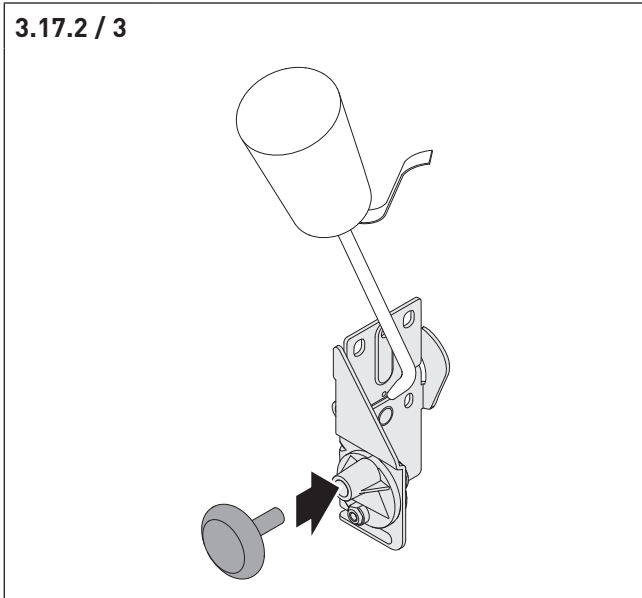

- ⇒ Oil the side hinge.
- ⇒ Insert the track roller in the roller brackets.

3.17.2 / 4

ø 4.5 / Type 1

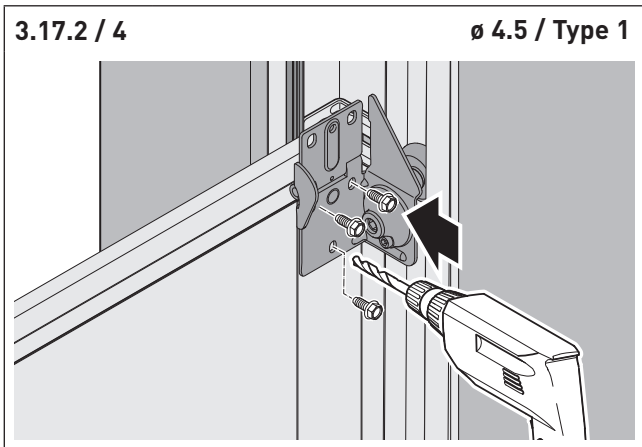

- ⇒ Slide the track rollers with the track roller bracket into the guide rail.
- ⇒ Screw the track roller brackets on the pre-drilled holes on the lower section.
- ⇒ Drill the hole for the lower screw connection.
- ⇒ Fasten the track roller bracket on the lower screw connections.
- ⇒ Adjust the track rollers.

Quadruple spring system

3.17.2 / 5

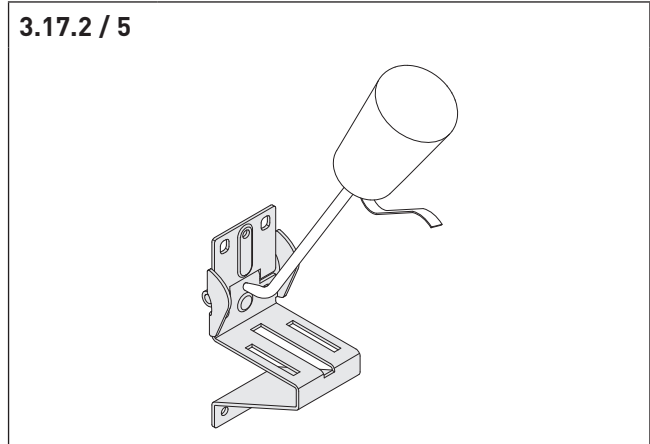

- ⇒ Oil the side hinge.

3.17.2 / 6

Type 1

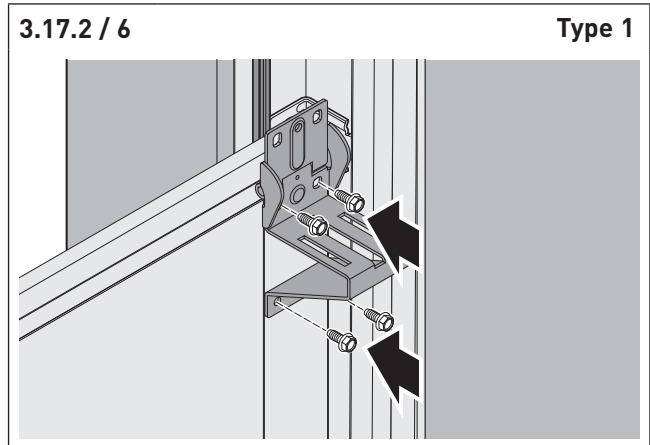

- ⇒ Fasten the side hinges on the drilled holes on the lower sections.

3.17.2 / 7

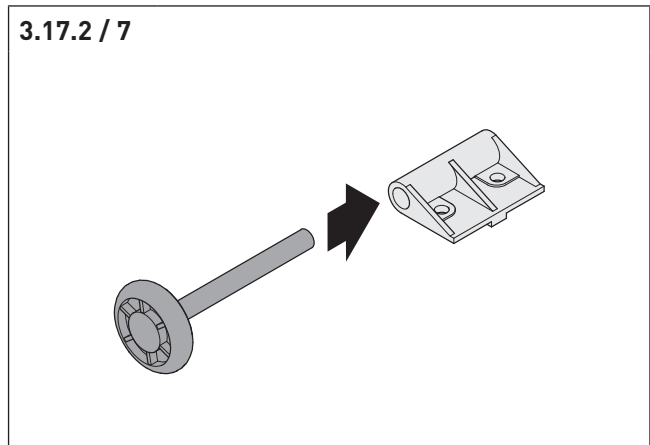

- ⇒ Insert the track roller in the roller brackets.

3.17.2 / 8

Type 11

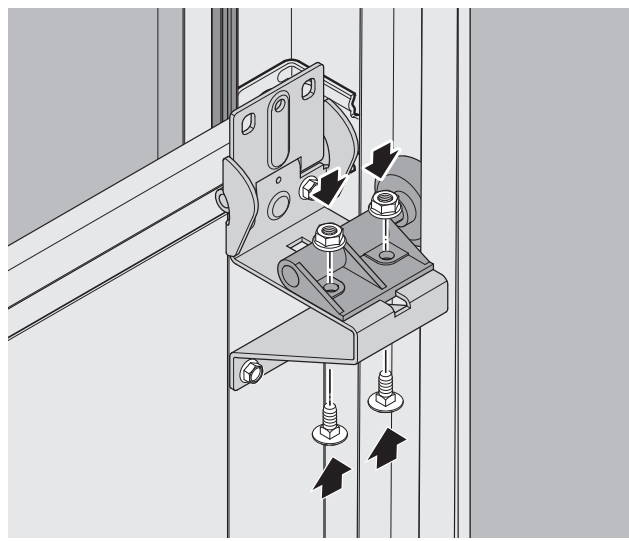

- ⇒ Slide the track roller into the guide rail.
- ⇒ Fasten the roller bracket together with the side hinge.
- ⇒ Adjust the track rollers.

All spring systems

3.17.2 / 9

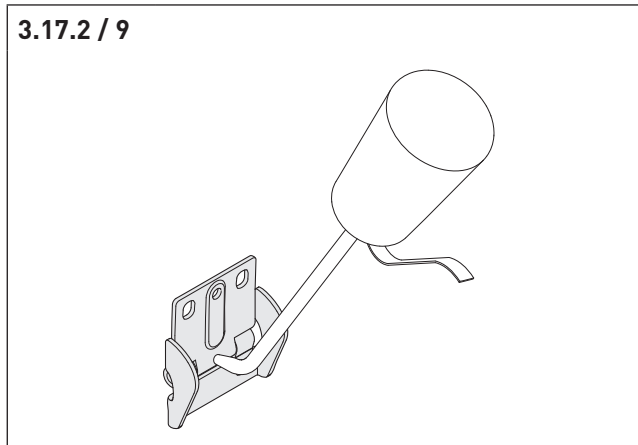

- ⇒ Oil the centre hinges.

3.17.2 / 10

Type 1

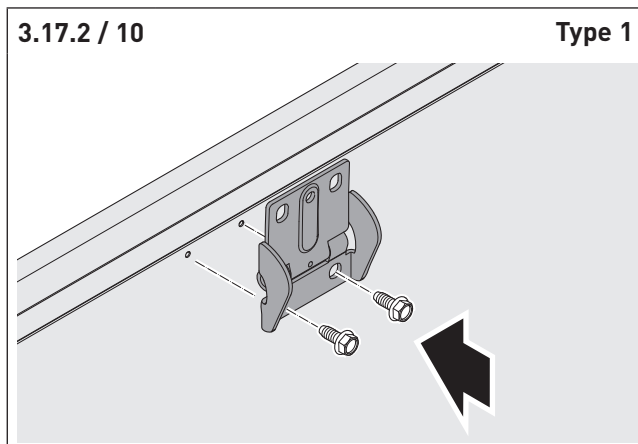

- ⇒ Screw the centre hinges on the lower section.
- ⇒ Observe the position of the hinge.
- 📄 "3.17.2 / 2"

⚠ WARNING!

The sections can be tilted into the room as long as they are not fastened to the previous section and the track roller brackets are not mounted.

3.17.2 / 11

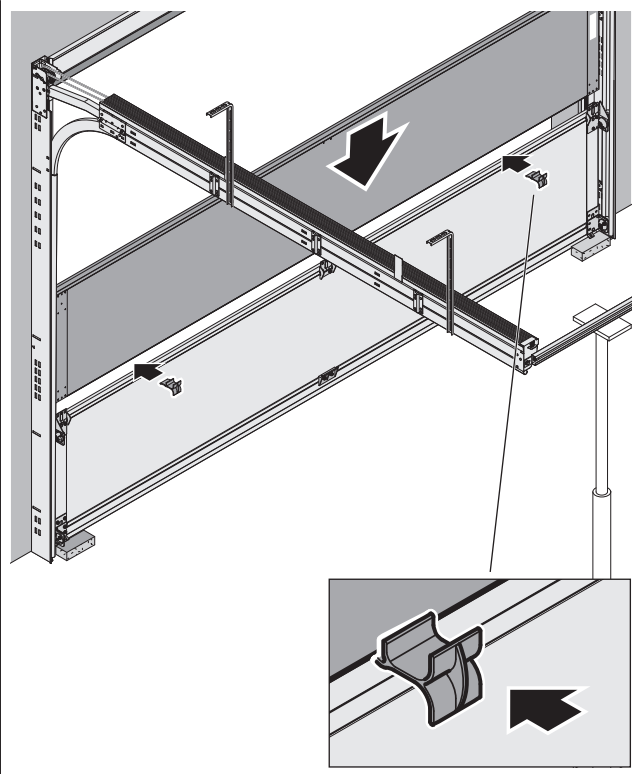

- ⇒ Screw the sections that you place in the opening.
- ⇒ Position the section with the type plate on the bottom section.
- ⇒ Insert the red spacers uniformly between the sections (at least 3 per panel).

The spacers must be removed after the sections are fastened. The spacers must be inserted between the sections before each additional screw connection.

Manually operated doors:

- ⇒ Now mount the handle group.
- The installation instructions are provided in the handle group package.

Double and triple spring system

3.17.2 / 12

Type 1

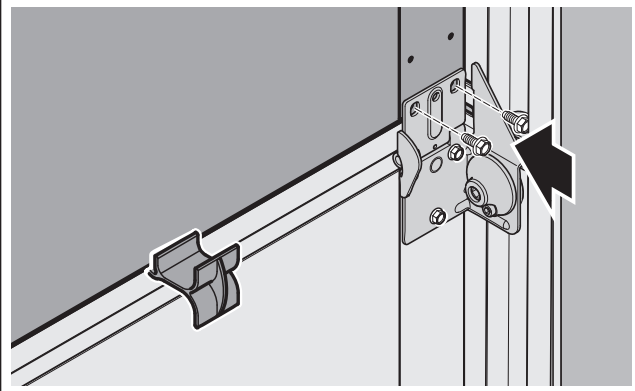

- ⇒ Screw the track roller bracket on the upper section.

Quadruple spring system

3.17.2 / 13

Type 1

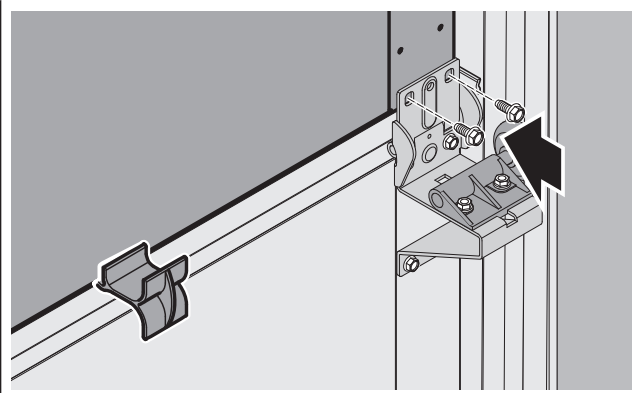

- ⇒ Screw the track roller bracket on the upper section.

All spring systems

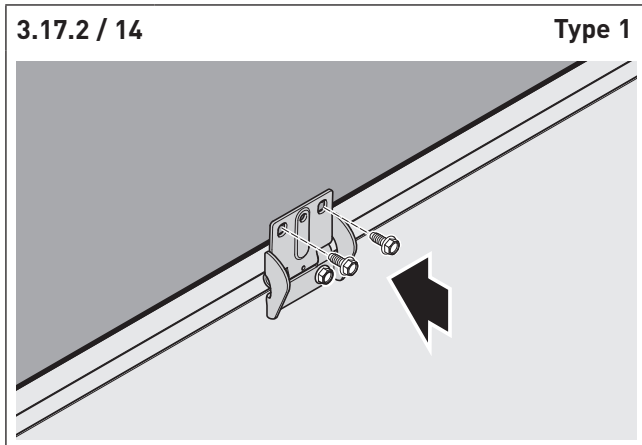

⇒ Screw the centre hinges on the upper section.

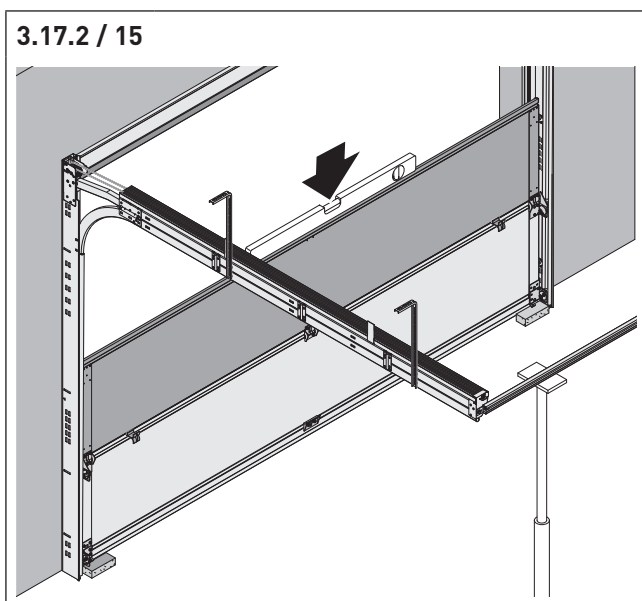

⇒ Check whether the door is aligned horizontally. You can adjust the height with wooden shims in order to align the door horizontally (refer to Fig. "3.17.1 / 14" and "3.17.1 / 16").

⇒ Mount all other sections up to the top (top section sticker), as described before (Fig. "3.17.2 / 1" to "3.17.2 / 15").

📄 Assembly of the upper section is described below.

3.17.3 Upper section (top section) assembly

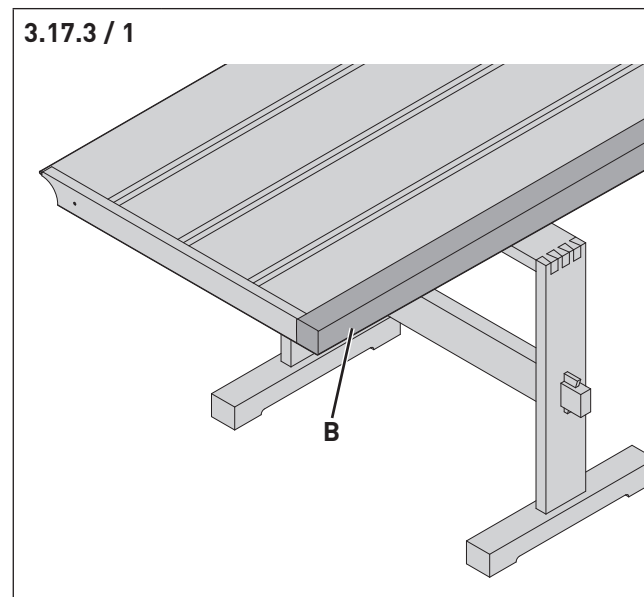

In special cases, the top section is completed with an aluminium profile (B).

For gates with a V70 reinforcement profile:

⇒ Now mount the V70 reinforcement profile on the top section.

📄 The assembly manual for this comes packaged with the V70 reinforcement profile.

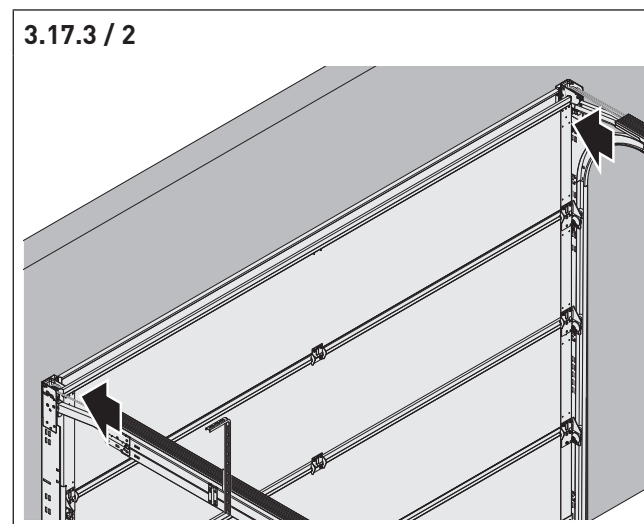

⇒ Position the top section of the previous section and fasten it as described above (refer to Fig. "3.17.2 / 3" to "3.17.2 / 13").

NOTE!

The holding brackets for the top roller holders must be connected flush with the outside of the upper door section.

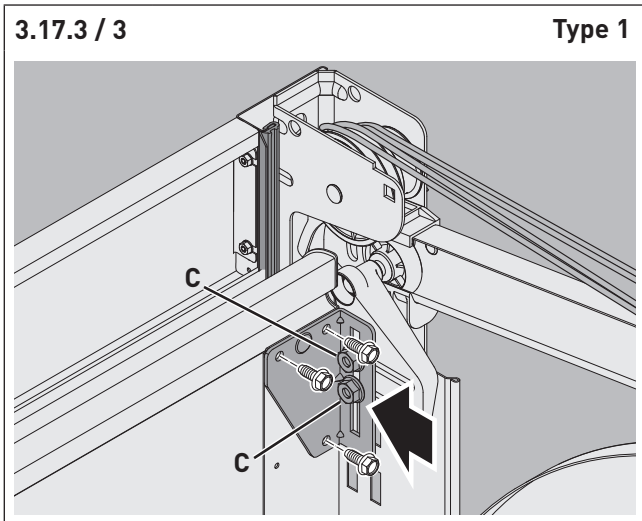

- ⇒ Loosen the screws [C].
- ⇒ Insert the roller of the top roller holder into the black plastic curved rail.
- ⇒ Screw the left and right holding brackets for the top roller holder onto the upper door section.

Lintel variant 240 mm

For the special case of the 240 mm lintel variant, the lower hole pattern must be used for installing the holding bracket (long) of the top roller holder.

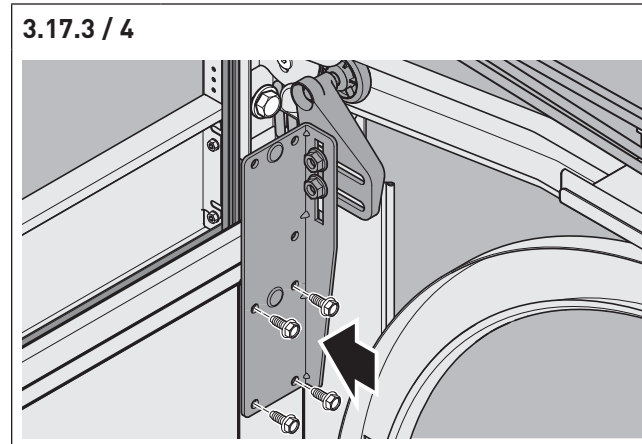

Track roller alignment

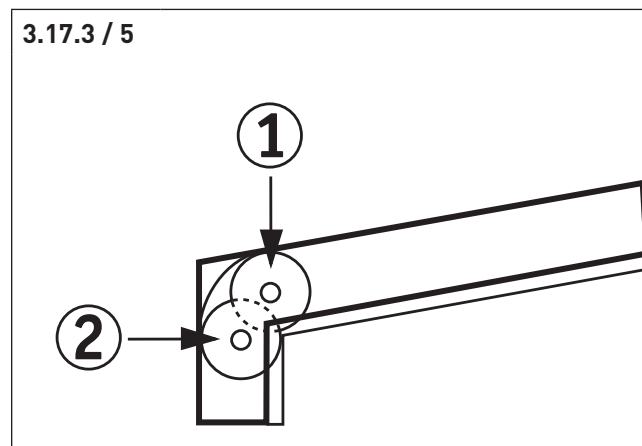

⇒ Align the track roller in the upper curved rail as follows:

Position 1

Roller at TOP in the curved rail:

- For doors **with** drive and without special brackets

Position 2

The roller barely engages behind the vertical curved rail section:

- For doors **without** drive (manual operation)
- For **all** doors with the 240 mm lintel variant

3.17.3 / 6

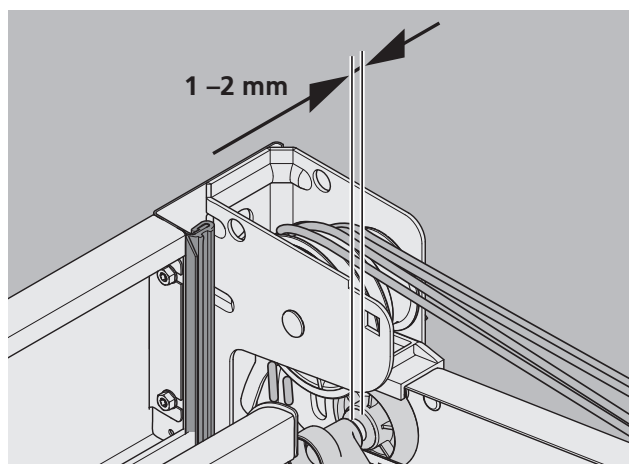

- ⇒ Make sure that the distance between the roller and the top roller holder is 1 mm to 2 mm during the entire door movement.

3.17.3 / 7

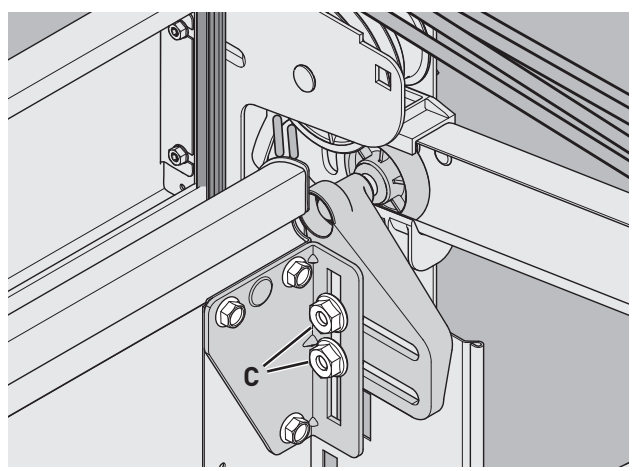

- ⇒ When you have adjusted the correct position for door, tighten the screws (C).

NOTE!

- The roller holder and the top roller holder must be aligned only while the door is closed.
- The securing screws must not be overtightened.
- **Do not** trap the sealing lips on the frame seal between the panel and the frame.

- ⇒ Align all roller brackets so that the rollers are in the track rail radius.

Double and triple spring system

3.17.3 / 8

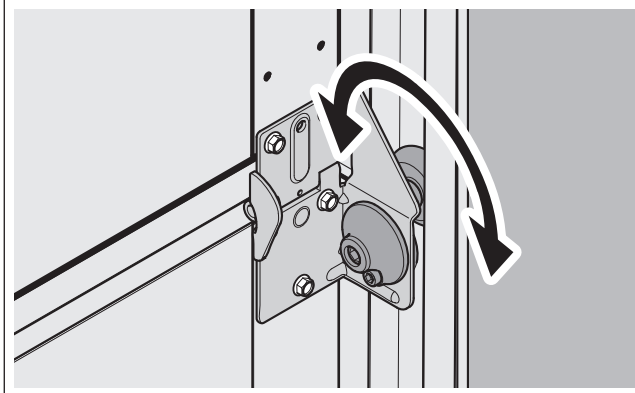

- ⇒ Pivot the track roller until it is correctly adjusted - Centre mount, 8 mm Allen wrench.
- ⇒ Re-tighten the fastening screw.

Quadruple spring system

3.17.3 / 9

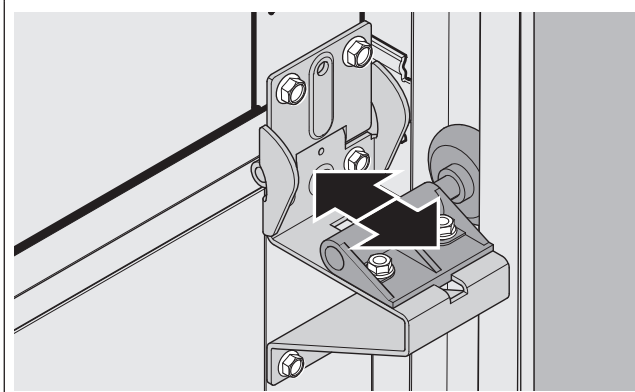

- ⇒ Shift the plastic roller bracket until the track roller is adjusted correctly.
- ⇒ Re-tighten the M6 nuts.

3.18 Assembly of the wire rope on the door leaf

NOTE!

The door is still not under spring tension.
The force that is necessary to open the door is supported by spring tension.

3.18 / 1

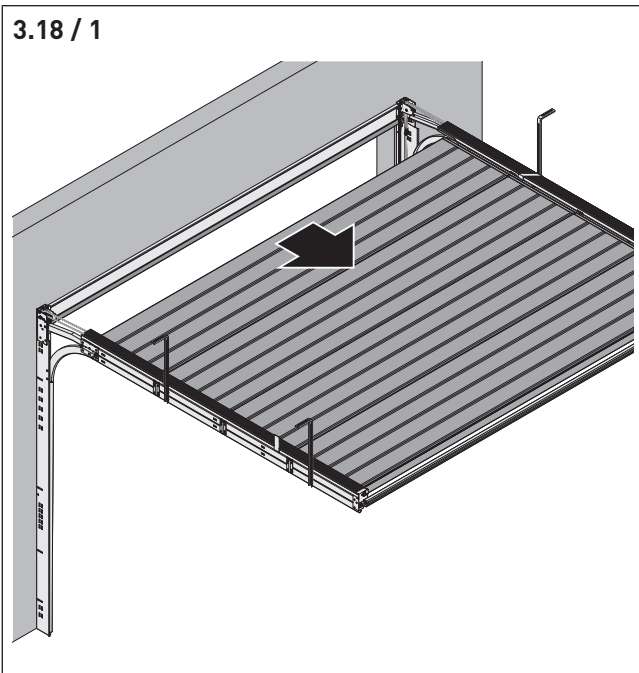

⇒ Open the door carefully to the limit position.

3.18 / 2

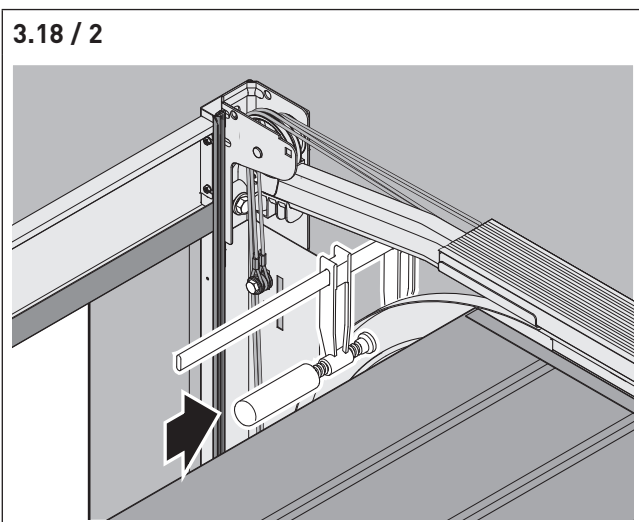

⇒ Secure the open door in the guide rail on the right and left with the screw clamps.

NOTE!

The bolts of the floor bracket must be freely accessible.

3.18 / 3

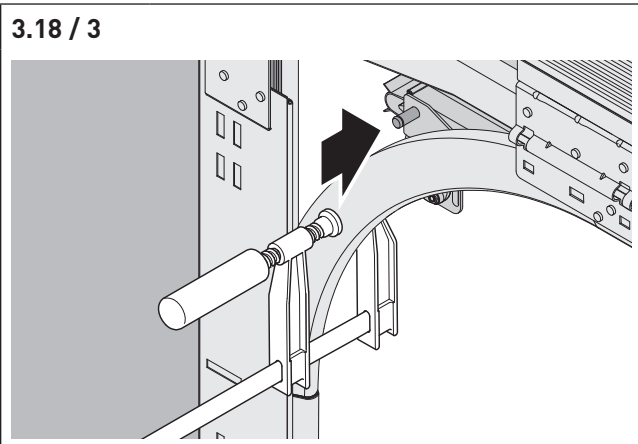

⚠ WARNING!

The rope is under tension from the spring.

3.18 / 4

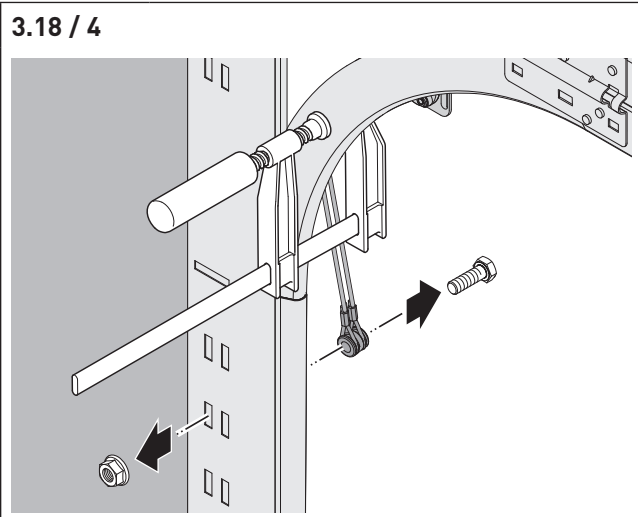

- ⇒ Fasten the rope firmly.
- ⇒ Do not leave the rope loose as long as it is secured.
- ⇒ Remove the screw from mounting bracket/frame.
- ⇒ Plug the rope take-up bushing onto the side mounting bolt of the floor console.

3.18 / 5

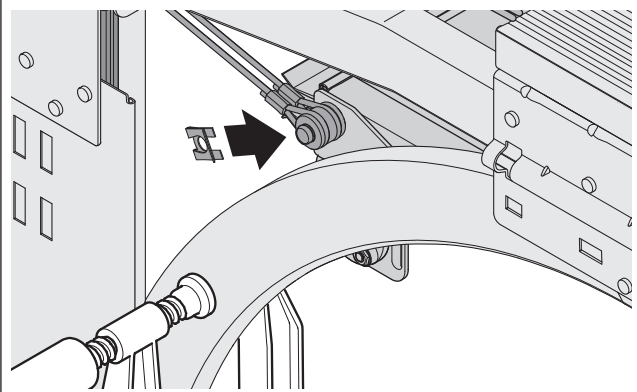

⇒ Secure the rope take-up bushing with the SL clip. The steps must be carried out inversely on the other side of the door.

! WARNING!

Make sure that the rope take-up bushing is secured before you remove the screw clamps.

- ⇒ Now you can remove the screw clamps (refer to Fig. "3.18 / 2").
- ⇒ Now you can remove wooden supports (refer to Fig. "3.17.1 / 15" and Fig. "3.17.1 / 16").

3.19 Spring tension adjustment

3.19 / 1

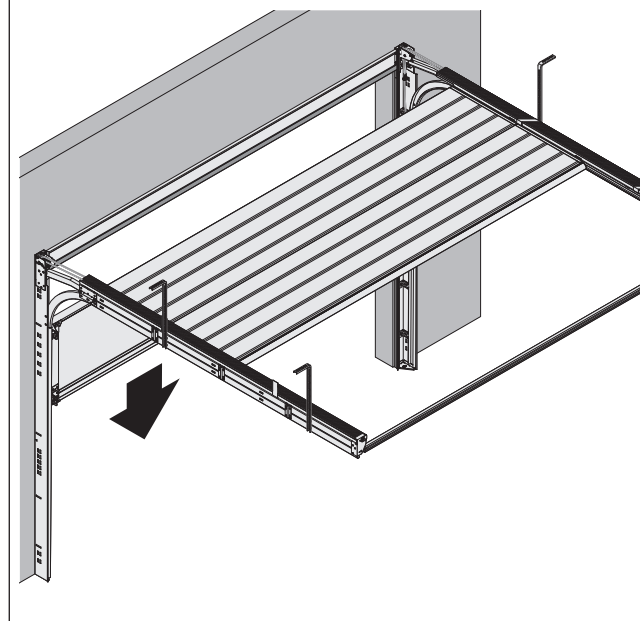

⇒ Close the door and check the spring tension.

NOTE!

- The spring tension must only be changed when the door is open.
- Both sides must always have the same tensions.
- The voltage must be adjusted to ensure easy raising and lowering.
- The rope must have adequate pre-tension at each door position.
- The rope must always be tensioned!

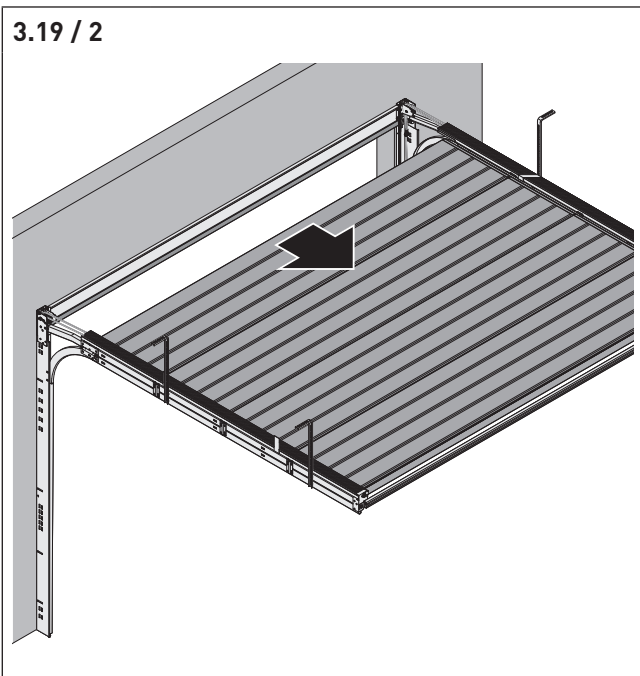

⇒ Open the door.

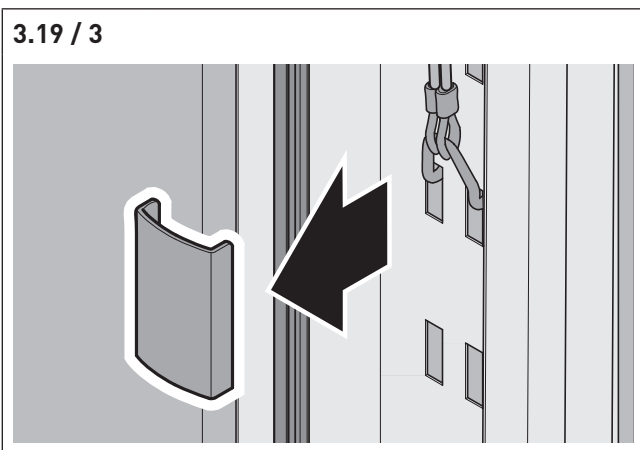

⇒ Remove the cover of the rope bracket.

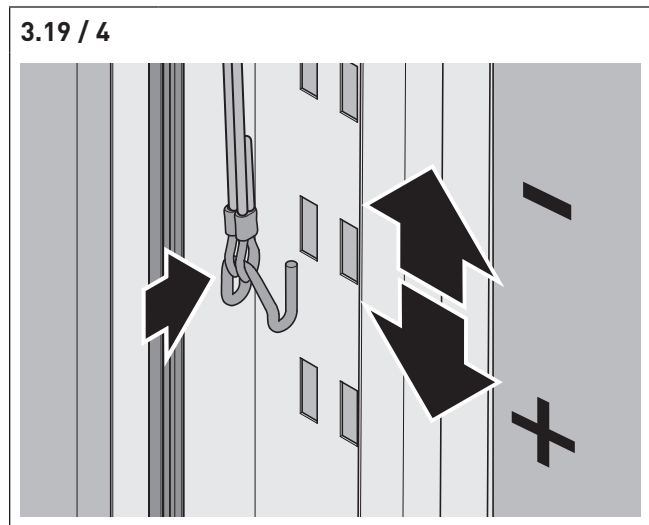

⇒ Adjust the correct spring tension by attaching the rope bracket in another hole.

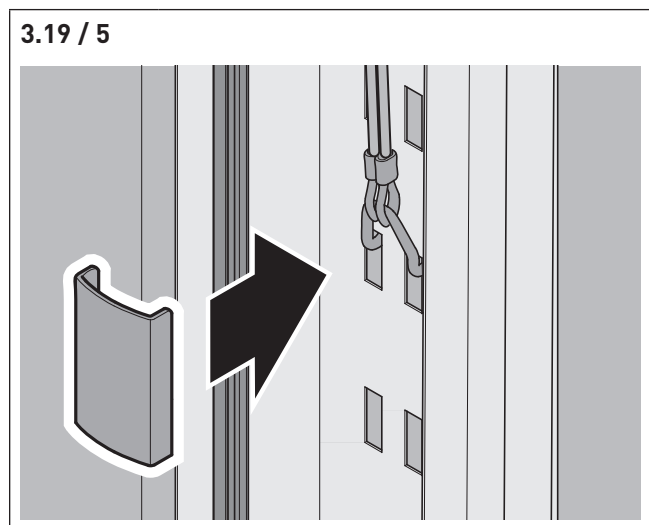

⇒ Mount the cover of the rope bracket.

3.20 Door carrier assembly

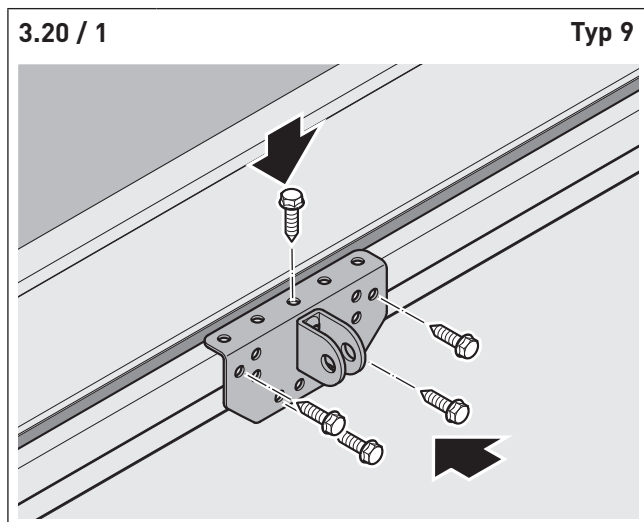

⇒ Mount the door carrier in the centre of the upper door section.

The door carrier should be fastened even if a drive is not mounted currently. The door carrier is specially designed for this sectional door and should also be used for retrofit drive assembly.

3.21 Pull rope assembly (optional accessory)

⚠ WARNING!

In order to avoid personal injury, the pull rope must not be used in combination with a drive!

With a retrofit drive, any existing rope must be removed!

With door heights of 2250 mm or higher

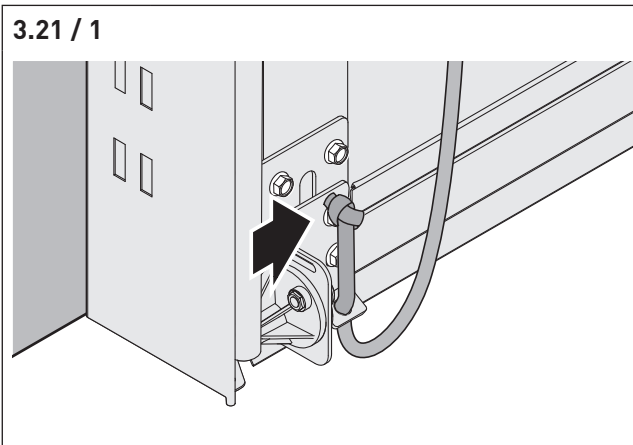

⇒ Insert the pull rope through the lug of the bottom bracket from below and tie the rope end.

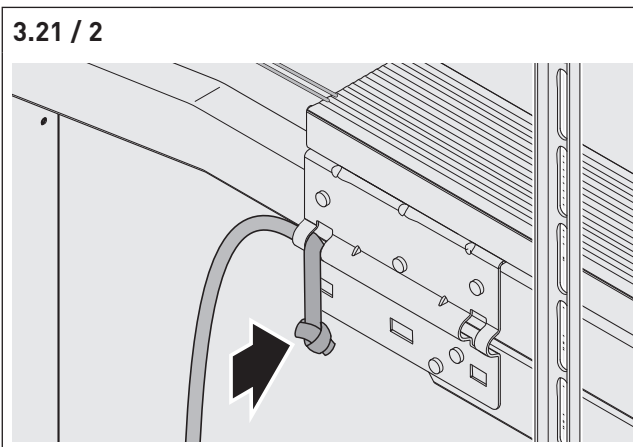

⇒ Insert the pull rope through the mount on the vertical frame from the front.
 ⇒ Pull the rope to the necessary length and tie the rope end.

4. Commissioning

4.1 Safety instructions for commissioning

WARNING!

To prevent damage and personal injury, make sure the door is secured:

- Have all installation steps been completed?
- Are the side guide rails fixed adequately?
- Are the springs tensioned as described on both sides?
- Are the door sections fastened at all intended positions and has the 2 mm gap between sections been observed?

4.2 Testing the door operation

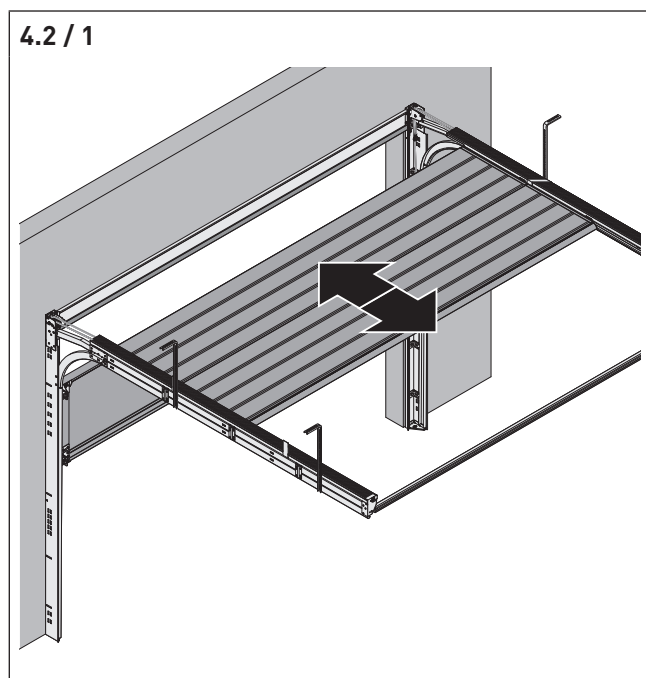

⇒ Open and close the door manually.

A successful test run must fulfil the following conditions:

1. The door must move easily.

- ⇒ If the door cannot be moved easily, check:
- Are the side frames aligned correctly (refer to section 3.7)?
 - Have the ropes twisted (refer to section 3.14)?
 - Are the side guide rails aligned horizontally (refer to section 3.16.1)?
 - Is the door leaf centred in the door opening (refer to section 3.17.2)?
 - Is the door leaf in a horizontal position when closed (refer to section 3.17.2)?

2. The door moves to the “Door open” and “Door closed” end positions.

- ⇒ If the door is not move to the end position “Door open”, check:
- Is there an obstacle blocking the path of the door? Check the guide rails, in particular.
 - Does the rope run correct on the deflection pulleys on both sides (refer to section 3.14)?
 - Is the spring tension correct (refer to section 3.19)?
 - The spring tension may be too low or too high.

3. The door remains in the catch between the end positions.

- ⇒ If the door does not remain in the catch, check:
- If the door moves forward, you must reduce spring tension (refer to section 3.19).
 - If the door closes further, you must increase spring tension (refer to section 3.19).

4.3 Remove protective film

NOTE!

The protective film on the outside of the sections must be removed, because it permanently adheres to the sections in heavy solar radiation!

- ⇒ Remove the protective film on the outside of the sections.

5. Operation

5.1 Safety instructions for operation

WARNING!

In order to avoid personal injury due to uncontrolled door movements:

- ⇒ Only open or close the door when the door opening is clear of obstruction.
- ⇒ Do not operate the door under heavy winds in order to ensure that control over the door is maintained.

5.2 Manually operated doors

- ⇒ Only operate the door with the controls provided for this purpose.
- ⇒ Move the door at a constant speed until the limit positions are reached.
- ⇒ When closing the door, ensure that the latch bolt engages.
The door is automatically locked in the CLOSED limit position.

Operation from outside - opening the door

- ⇒ Unlock the handle with the key.
- ⇒ Turn the handle clockwise, then lift the door a few centimetres.
The door is unlocked.
- ⇒ Slide the door to the OPEN limit position. The handle does not have to be turned in the process.

Operation from outside - closing the door

- ⇒ Move the door to the CLOSED limit position.
The lock engages automatically when the door is closed.

Operation from inside - opening the door

- ⇒ Unlock the handle with the securing lever on the lock.
- ⇒ Turn the handle clockwise, then lift the door a few centimetres.
The door is unlocked.
- ⇒ Slide the door to the OPEN limit position. The handle does not have to be turned in the process.

Operation from inside - closing the door

- ⇒ Move the door to the CLOSED limit position.
The lock engages automatically when the door is closed.

5.3 Power-operated doors

WARNING!

In order to avoid personal injury due to uncontrolled door movements:

- ⇒ that the control unit and handheld transmitter are not used by children or unauthorised persons.
- ⇒ Ensure that the handheld transmitter is not inadvertently actuated (e. g. in the pocket of your trousers).

-  Refer to the documentation for the drive system for information about the operation of the door drive.

6. Cleaning

Clean glass surfaces

NOTE!

In order to avoid damaging glass surfaces, glass cleaner must not be used (due to aggressive ingredients). Never use abrasive cleaners, scrapers, razor blades or scrapers, etc.

1. Flush with flowing water.
2. Clean with warm water, a small amount of mild plastic cleanser and clean, soft, lint-free rags.

7. Service

Maintenance

WARNING!

A damaged door can cause severe or deadly injuries. If there are signs of damage, fractures, or tears, the door must be immediately shut down and repaired by a qualified expert in accordance with EN 12635.

7.1 Maintenance work by the owner

Maintenance at least every 12 months

- ⇒ Check the rollers.
- ⇒ Oil the hinges and track rollers.
- ⇒ Check the adjustments of the rollers.
- ⇒ Check the seating and fastening of all screws.
- ⇒ Visually inspect all components for cracks and damage.

7.2 Maintenance work by qualified, trained specialist personnel (in accordance with EN 12635)

Maintenance at least every 6 months

- ⇒ Inspect the steel ropes for damage, fractures, and tears.

Maintenance at least every 12 months

- ⇒ Re-tighten the springs as necessary.
- ⇒ Check the springs.

8. Disassembly and disposal

8.1 Disassembly

WARNING!

Life-threatening danger due to electric shock in door systems with a drive system!

- ⇒ Prior to disassembly, disconnect the drive system and control unit from the power supply.
- ⇒ Ensure that the power supply is disconnected during disassembly.

WARNING!

Severe injury possible due to falling parts!

- ⇒ Secure the door system to prevent falling prior to disassembly.
- ⇒ Observe all applicable occupational safety regulations.

Disassembly must be carried out by qualified, trained personnel in the reverse order of the assembly described in this manual.

8.2 Disposal

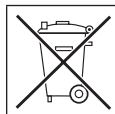

The door system must not be disposed of with the household waste!

- ⇒ Dispose of used equipment of the drive system in a collection centre for electronic scrap or with your specialist dealer.
- ⇒ Dispose of the door system with the local waste disposal in accordance with locally applicable waste disposal regulations.

9. Annex

9.1 Warranty

Wear parts have a limited service life due to the frequency of use and are not covered by the normal warranty!

The following apply as wear parts:

- Springs
- Ropes
- Track rollers
- Seals
- Rope pulleys
- Drive system
- Locks / lock
- Bowden cables
- Hinges

Warranty for function and security can only be recognised if:

- safety and warning notices are observed,
- installation is carried out correctly and in the sequence of the manual,
- only original Teckentrup parts and accessories are used,
- no additional objects are fastened on the door,
- the components of the scope of delivery are not modified or converted,
- regular maintenance of the door is carried out,
- the owner is aware of all relevant operating instructions (door, drive system and safety equipment).

Disregard of these installation and operating instructions voids the warranty.

Any questions? We would be glad to help! Contact your Teckentrup consultant.

Contact information:

Teckentrup GmbH & Co. KG

Industriestraße 50 • 33415 Verl

T: +49 (0) 5246 504 - 0 • F: +49 (0) 5246 504 - 230

info@teckentrup.biz • www.teckentrup.biz

TECKENTRUP
DOOR SOLUTIONS

WWW.TECKENTRUP.BIZ

0112022 (EN) 207730