



Operating / Assembly Instructions and Installation Data

for

“ ew-RP-GUP, dw 50-GUP “

Updated: 06.2008

Teckentrup GmbH & Co. KG
Industriestrasse 50
33415 Verl-Sürenheide
Phone: 00 49 (0)5246 / 504-0
Fax: 00 49 (0)5246 / 504-230

Teckentrup GmbH & Co. KG
Postfach 3113
33326 Gütersloh
Internet: www.teckentrup.biz
E-mail: info@teckentrup.biz

1. Contents

1.	Contents	2
2.	General Information.....	4
2.1	Types of walls.....	4
2.2	Maintenance/Inspections/Repairs	4
2.3	Operation / Utilization	5
3.	Warranty	6
4.	Outside Doors	7
5.	Assembly	8
5.1	Preparation	8
6.	Assembly Process.....	9
7.	Finger Pinch Protection Profile (Rubber Accident Protection Profile (GUP)).....	12
8.	Installation Versions (Wall Connections).....	13
8.1	Corner installation	13
8.2	Installation in front of the soffit version 1 (standard, dimension X = 60)	14
8.3	Installation in front of the soffit version 2 (dimension X > 60)	15
8.4	Corner installation with angular frame.....	16
8.5	Installation in the soffit.....	17
9.	Headroom Designs	18
9.1	Corner installation, 90 °opening	18
9.2	Corner installation, 180 °opening, single rail.....	18
9.3	Corner installation, 180 °opening, double rail	19
9.4	Installation in front of the soffit, 90 °opening	19
9.5	Installation in front of the soffit, 180 °opening, single rail.....	20
9.6	Installation in front of the soffit, 180 °opening, double rail	20
9.7	Installation in the soffit.....	21
10.	Bottom Door Leaf	22
10.1	Floor recess installation.....	22
11.	Drive and Protective Mechanisms / Fire Brigade Unlocking.....	23
12.	Leaf Hold-Open Devices	23
13.	Door Hold-Open Devices	23
14.	Glazing Elements.....	24
14.1	Aluminium clamping profile	24
14.2	Rubber clamping profile	24
14.3	Steel glass strip	24
15.	Wicket Doors	25
15.1	Wicket door without threshold and folding door with lower bracket	25

15.2	Wicket door without threshold and folding door without lower bracket	25
15.3	Wicket door with threshold and folding door with lower bracket	26
15.4	Wicket door with threshold and folding door without lower bracket	26
16.	Sectioned Access Door Panels	27
17.	General Safety Instructions for Assembly	28

2. General Information

- These assembly instructions provide an overview of the current development status.
- We have taken great care to ensure the high quality of these instructions. We shall not accept responsibility or liability for any printing errors or omissions.
- The instructions are subject to technical changes.
- In order to guarantee correct functioning and safe operation of the door only use original parts as accessories, e.g. fittings, door latches, locks, locking mechanisms. Spare parts and accessories can be purchased from your authorized dealer and Teckentrup GmbH & Co. KG.

Important:

- For safety reasons, only use the wall plugs or bolts recommended by the door manufacturer when mounting with plugs.
- The following wall plugs are recommended:
 - for masonry Fischer FUR,
 - for concrete Fischer FAZ or FH-S,
 - for autoclaved aerated concrete, etc. possible fixing options on request.Mounting types not specified in these installation instructions require prior release by Teckentrup GmbH & Co. KG.
- **These instructions have been created for authorized technicians in accordance with EN 12635 requirements. Door assembly should only be carried out by technicians who fulfil these requirements.**
- Welding at the suspension should only be carried out by qualified welders (DIN EN 287-1, Qualification test of welders, Fusion welding).

2.1 Types of walls

The static stability of the frame and runner rail installation has to be designed for the weight of the door! Static inspection/Documentation has to be provided by the customer!

The folding sliding door can be mounted to the following walls:

- **Masonry** in accordance with DIN 1053-1, min. masonry compressive strength class 12, min. masonry mortar group IIa, **wall thickness ≥ 240 mm** or
- **Concrete** in accordance with DIN 1045, min. masonry strength class B15, **wall thickness ≥ 140 mm.**
- **Autoclaved aerated concrete blocks and high precision units** – in accordance with DIN 4165, min. masonry strength class 4
- **Steel constructions** with static documentation

2.2 Maintenance/Inspections/Repairs

The owner or a person authorized by him/her has to visually inspect functionality of the door system regularly and to check for any external damages in accordance with the section entitled "Maintenance". Repair work should only be carried out by specialist technicians or Teckentrup GmbH & Co. KG. Immediately ensure that an unsafe door cannot be operated until it has been correctly repaired by a specialist or the door manufacturer. Always observe the relevant regulations for the maintenance and inspection of power operated doors in accordance with EN 12635 and create a maintenance protocol. Record all the inspections carried out. Only use original parts to replace defective ones. Please contact Teckentrup GmbH & Co. KG

Maintenance

Teckentrup steel folding sliding doors are characterized amongst other things by their maintenance-friendly design. However, to guarantee correct functioning of the steel folding sliding door, professional maintenance must be carried out by a specialist technician at least once a year.

The owner or a person authorized by him/her has to visually inspect the functionality of the door system once a week and to check for any external damages in accordance with the following points.

General status

- Visual inspection of the door leaf, guide rails, seals, glazing.
- Inspection of the attachment of guide rails, lateral and upper frame elements and hinges; if necessary, retighten attachments, clean guide rails and lubricate with a resin-free lubricant.
- Inspection of the correct positioning of hinges, including hinge bolts; if necessary, retighten fixing screws and lubricate hinge bolts.

Make sure that the following components are functioning and connected properly:

- Secure rod bolts
- Door hold open device (wall hold open device, lock bar, etc.)
- Leaf hold open device
- Guide roller
- Locks and fittings

Have a specialist carry out inspections as soon as any problems are detected (e.g. sluggishness, unusual noises, damages, etc.)

2.3 Operation / Utilization

- The ready-for-use door must satisfy the requirements of **EN 12604**.
- Before opening the closed door ensure that no wind load can cause any sudden and uncontrolled door movements.
- Never place any objects within the movement range of the door.
- Ensure that nobody can be trapped or injured between objects or the wall and the opening and closing door.
- The secure rod bolts should always be completely locked when the door is closed.
- Secure the open leaves, the open door via the leaf or wall and/or floor fixing devices.
- Never step between the folding door leaves.
- Remove any unauthorized persons from the opening and closing zone.



3. Warranty

Warranty with regard to functioning and safety can only be guaranteed if

- the safety and warning notices are adhered to,
- assembly has been carried out correctly in accordance with the instructions,
- only original Teckentrup accessories are used,
- no additional objects are attached to the door,
- the supplied parts have not been adjusted or adapted,
- regular maintenance of the door and its accessories is carried out,
- there is no damage caused by improper use or external influences.
- Warranty does not cover glazing elements not installed by the manufacturer.
(see point 14)

4. Outside Doors

- Check whether the intended type of mounting is correct for the planned application. For outside doors, the door should preferably be mounted on the inside and open inwards.
- Doors mounted on the outside have to be equipped with a rain cover above the roller track.
- Outside doors should not swing open onto public thoroughfares.
- Ensure sufficient drainage in the area in front of the door. If necessary, plan a sloping surface or a drain gutter in front of the door. Avoid a build up of water underneath the door.
- Make sure that the building is dry and sufficiently ventilated.
- It is essential to immediately paint a top coat on outside doors after assembly if the door has been coated with a 2K HS primer filler. The door can be painted with standard top coat paint. If the door has been factory coated with an environmentally friendly powder primer, the surface must be lightly sanded and thoroughly cleaned before being painted. A solvent-containing 2K polyurethane varnish can be used for single-layer painting. When using synthetic resin varnishes, a solvent-containing epoxy undercoat must be applied in advance. **A top coat must be painted on a powder primer within 3 months.**
- Weld mounting surfaces at the C-shaped profile wall frames must be painted after welding (touch-up paint is included in the accessories)

Caution!

The application of top coats containing alkyd resin on galvanized substrates can lead to a later loss of adhesion of the overall coating on outside surfaces which are exposed to harsh weather conditions. In these cases, it is recommended to use 2K acrylic or 2K polyester paints.

5. Assembly

5.1 Preparation

- Ensure that the wall is plumb and level prior to assembly.
- Carry out plastering and painting work after assembling the door.
- Precisely even out any unevenness, etc. on the wall with pressure-resistant steel discs.
- The folding door has to be mounted to the adjacent constructional elements tightly enough to ensure that the static loads of the closed and open door as well as the dynamic load of the opening and closing door are permanently borne. These forces should not affect the stability of the adjacent wall.
- Ensure that the door is covered before plastering or painting work is carried out, since spots of mortar, cement, plaster or paint can damage the door surface.
- Make sure that the door does not come into contact with corrosive and caustic agents such as saltpetre reactions from bricks or mortar, acids, alkalis, road salt, chlorine, corrosive paints or sealing compounds.
- Always observe and adhere to local regulations if the door is installed in potentially explosive areas. The company commissioned with installing the door has to be informed of these regulations by the owner. Earthing measures should only be carried out by qualified electricians.
- Before you start make sure there are no electric cables or water or gas pipes behind the wall at the attachment points.



6. Assembly Process

- 6.1 Check the completeness and correctness of the delivery including the individual parts and accessories.

- 6.2 Compare the wall opening dimensions (width, height, diagonal) with the dimensions on the installation dimension drawing.

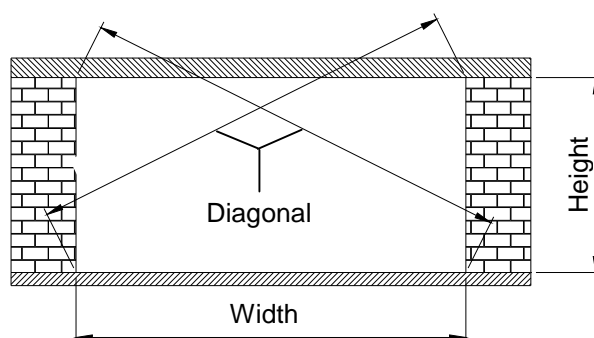

- 6.3 Prior clarification is required if any deviations regarding the points 6.1 and/or 6.2 are detected.

- 6.4 Refer to the installation plan on the installation diagram supplied with the door for details of the attachment point arrangement when mounting with wall plugs.

- 6.5 Screw the C-shaped profile side parts to the upper part of the frame and align them. For larger door dimensions, align and fix the frame parts individually.

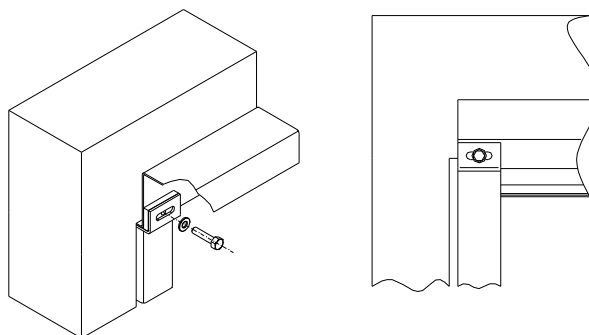

- 6.6 Horizontally align the upper part of the frame and subsequently weld it to the attachment points or the available steel construction. Use a spirit level with alignment bar or a tube level for this task. A tube level is required for larger door widths.

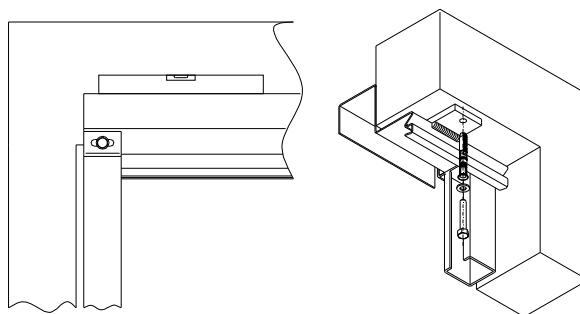

- 6.7 Align a part of the frame at a right angle to the upper frame and weld it to the attachment points or the available steel construction.

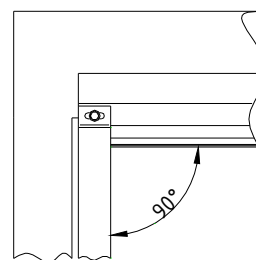

- 6.8 Lubricate the connecting steel bolts and the ball bearings.

- 6.9 Mount the leaves in accordance with their markings.

- 6.10 Check the size of the gaps between the leaves. Especially with larger doors it is possible that the inner leaves drop slightly, resulting in leaf impacts which are not parallel to each other.

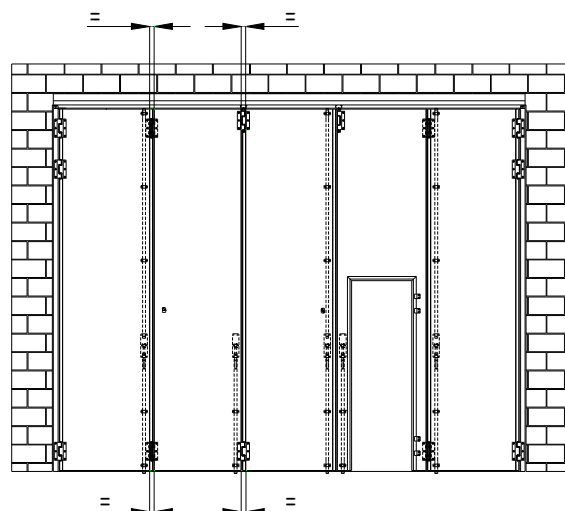

The respective leaf must be re-adjusted at the hinge part.

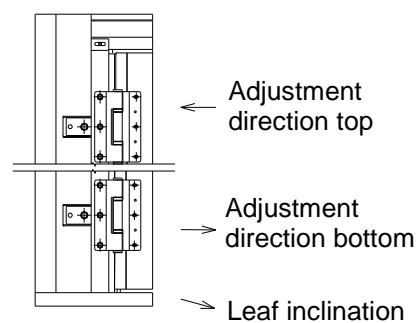

Once the leaf impacts are parallel, the hinge parts are pinned to the leaf.

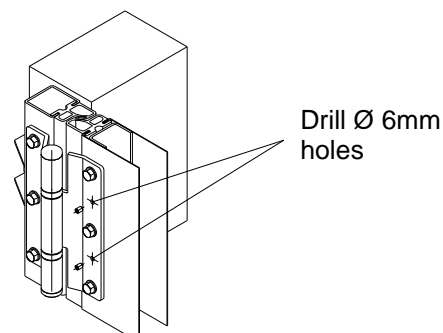

6.11 **Caution!**

Always ensure that the door leaves are secure and cannot fall down if the frame side parts have not yet been fully fitted!



- 6.12 The guide rollers of the door leaf are designed to guide the door and not to bear loads. To set the guide roller, loosen the counternuts about 5 turns. Slowly open and close the door several times and monitor the distance between the upper counternut and the bracket. Subsequently tighten the counternuts at the highest point to prevent damages to the guide roller or runner rail.

- 6.13 The distance between the mounted leaves and the finished floor should be ~10 mm or ~15 mm.
(see point 10)

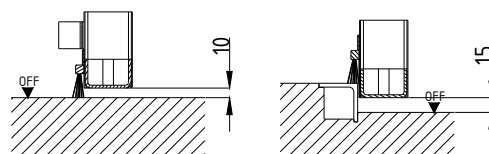

- 6.14 After a respective function test (operate all leaves once) the second part of the frame is aligned and welded to the attachment points or the steel construction. After unscrewing the fastening screw to the upper frame (header) the side parts can be laterally moved prior to welding.

- 6.15 The attachment points have to be bent outwards and set in concrete for doors with a lower bracket.

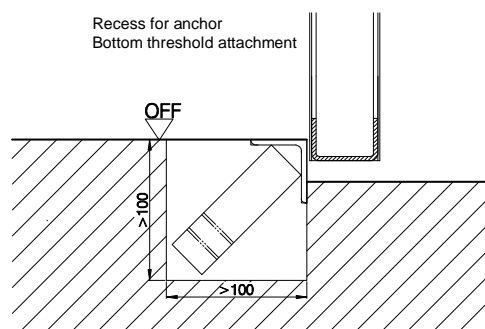

- 6.16 Attach the fittings and the fixing devices (if not carried out by the manufacturer!).
- 6.17 Clean the installation welding points correctly and treat the weld seams with zinc dust paint, touch up the primer on primed parts.
- 6.18 Clean the running surfaces of the guide rails and paint with a resin-free oil.
- 6.19 Connecting joints (frame/wall) must be sealed using a permanently elastic sealing compound.

7. Finger Pinch Protection Profile (Rubber Accident Protection Profile (GUP))

The finger pinch protection profiles at the vertical leaf edges are elastic enough to fulfil all current safety standards.

They guarantee accident-free operation.

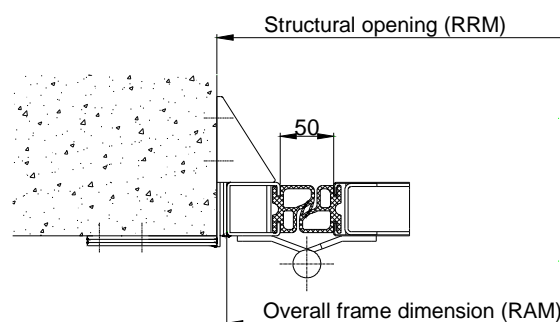

Caution!

The finger pinch protection profile on doors with an even connection (e.g. 0:2; 2:2; 4:2) has to be reduced at the top to such a degree that the outer leaf edges equipped with a one-sided leaf guide roller (approx. 25 mm) as to ensure that the profile does not hit the upper frame when opening and closing the door.

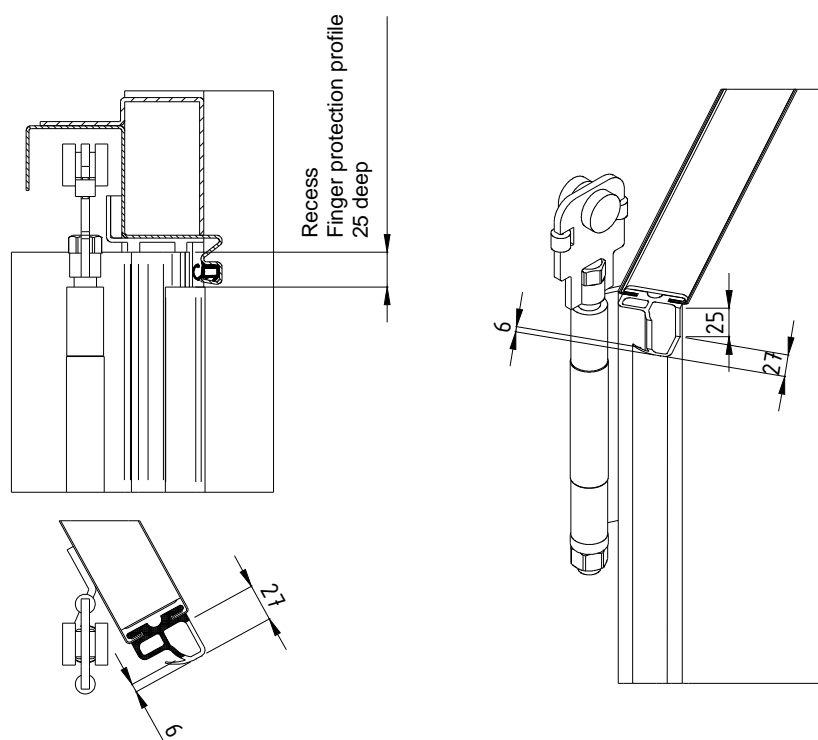

8. Installation Versions (Wall Connections)

8.1 Corner installation

Installation aid bracket

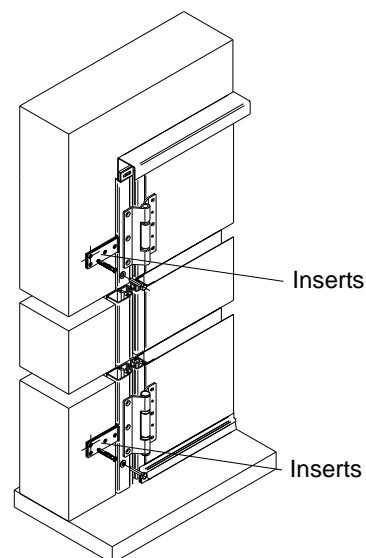
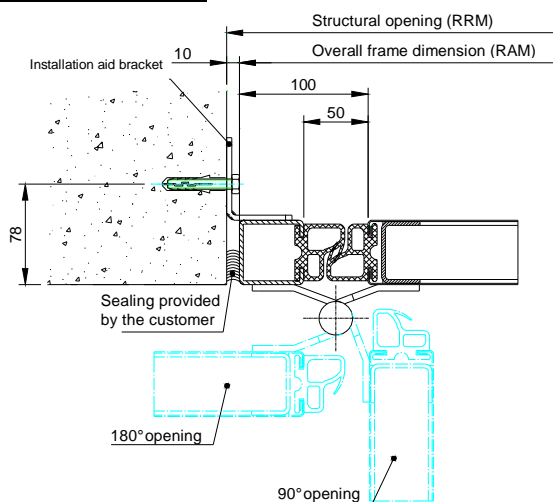

Fixing shoe

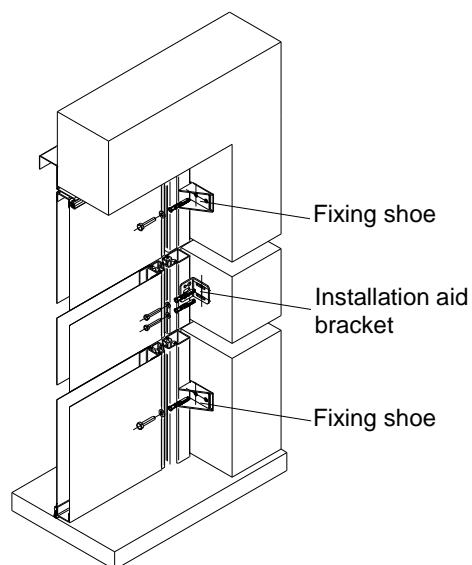
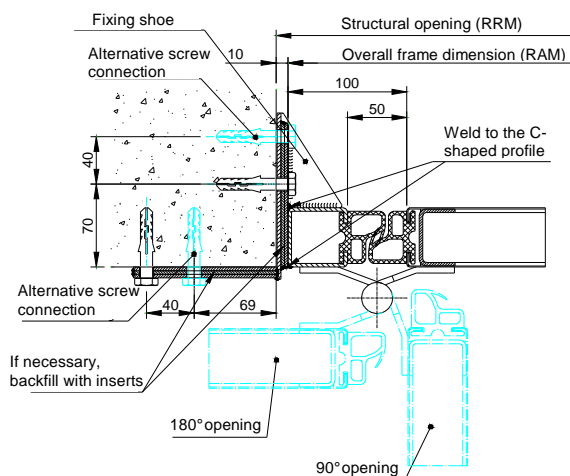

8.2 Installation in front of the soffit version 1 (standard, dimension X = 60)

Installation aid bracket

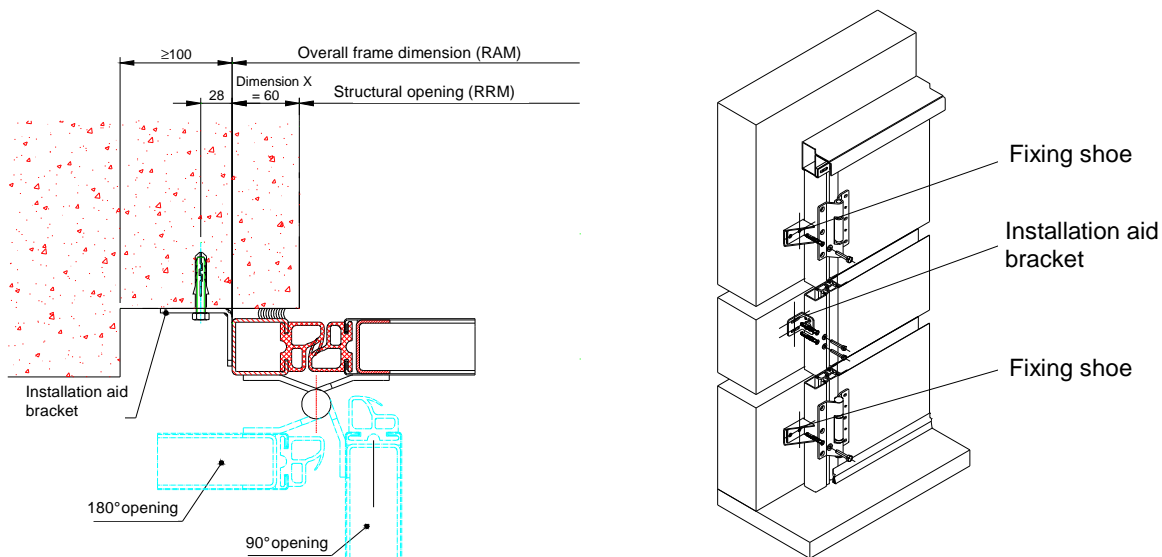

Fixing shoe

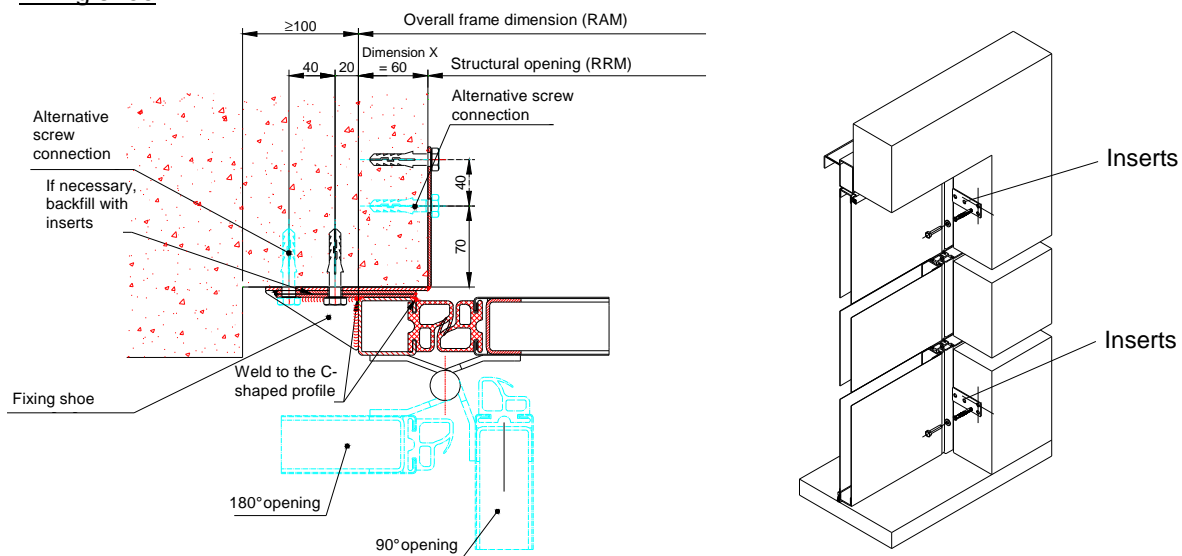

8.3 Installation in front of the soffit version 2 (dimension X > 60)

Installation aid bracket

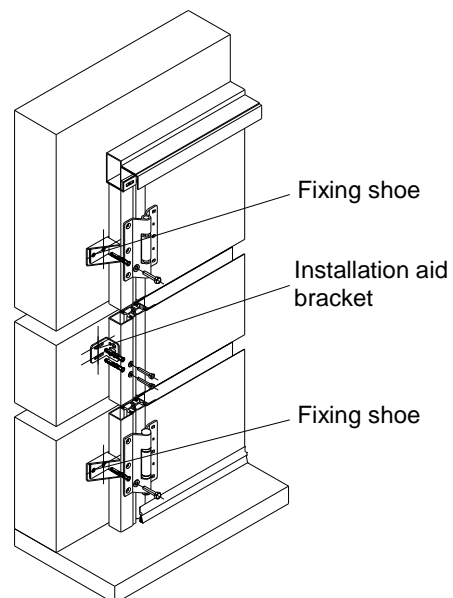
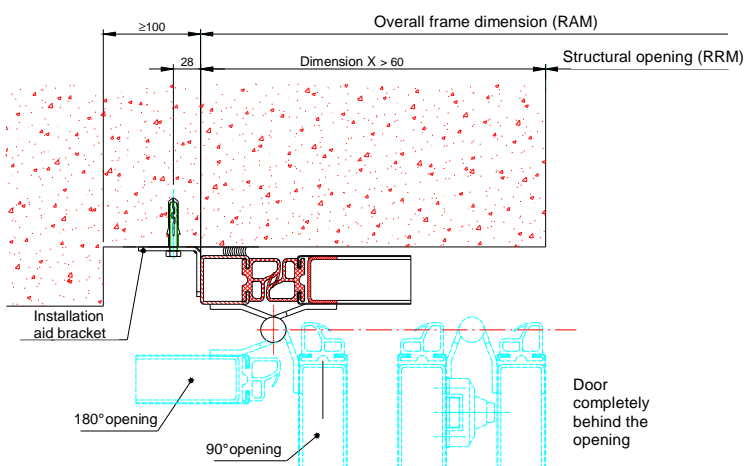

Fixing shoe

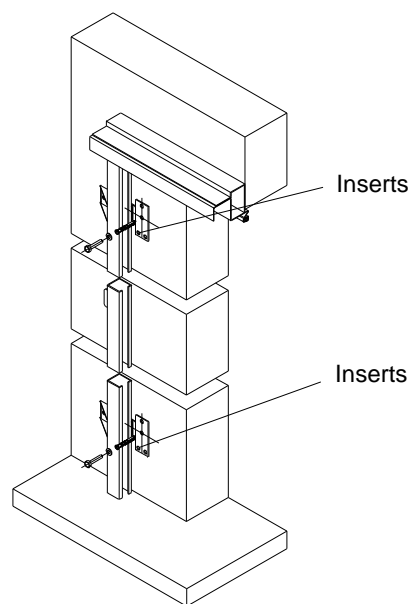
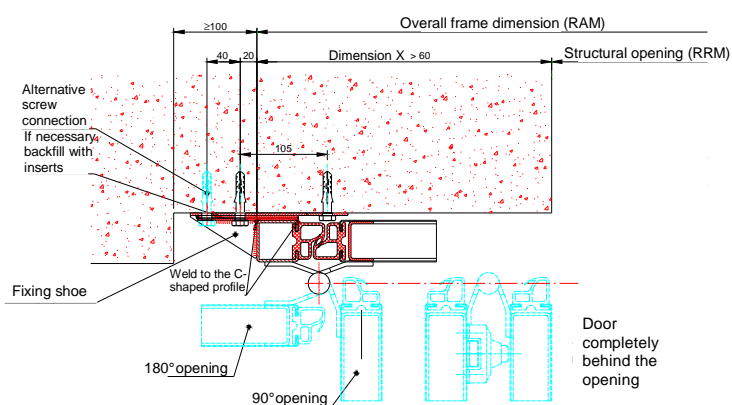

8.4 Corner installation with angular frame

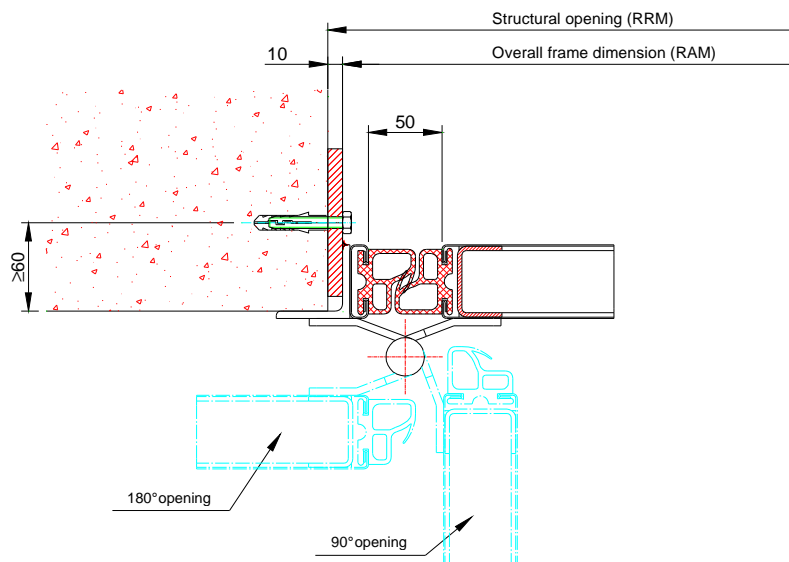

Caution!

When using the corner installation with angular frame, the angular frame must be plumb and not twisted otherwise the rubber profile will not close and seal correctly!

8.5 Installation in the soffit

Installation aid bracket

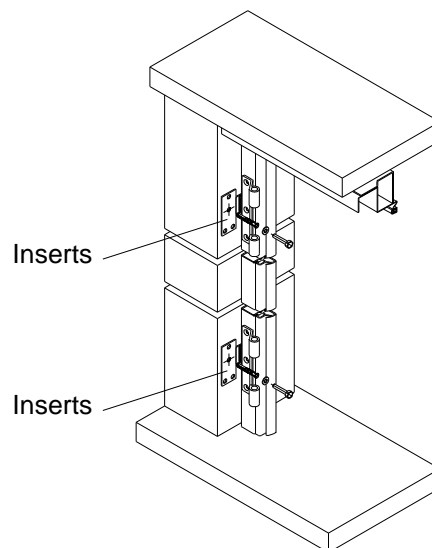
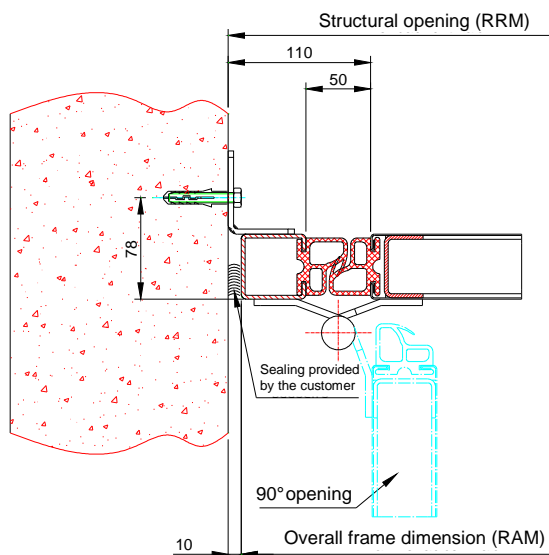

Fixing shoe

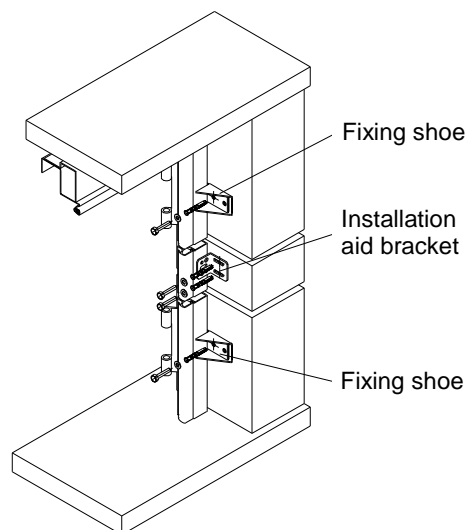
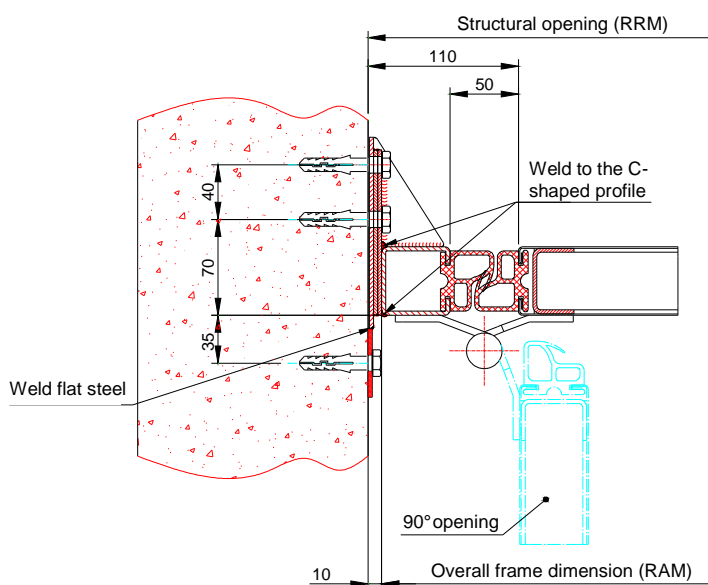

9. Headroom Designs

Note:

Please be extremely carefully when drilling the headroom and the soffit edges not to damage the headroom and the wall.

9.1 Corner installation, 90° opening

(outward opening shown)

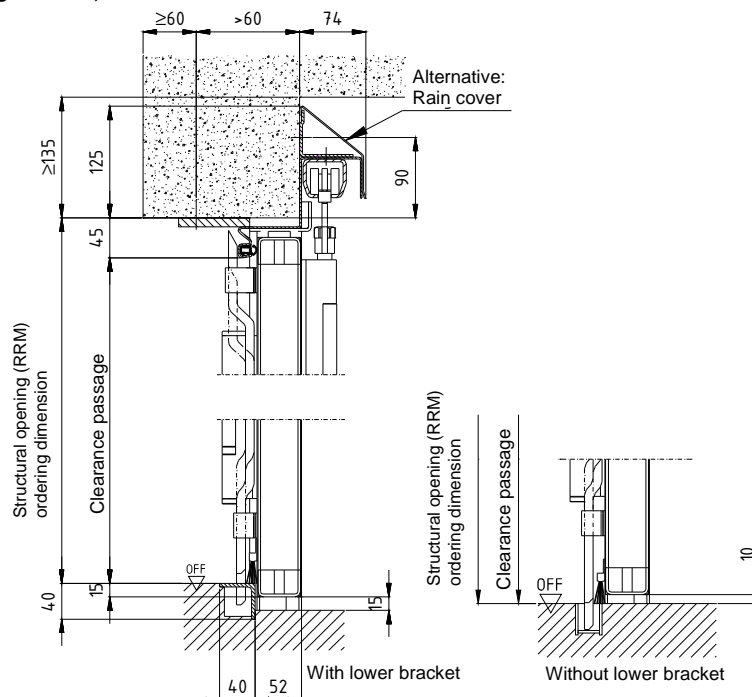

9.2 Corner installation, 180° opening, single rail

(outward opening shown)

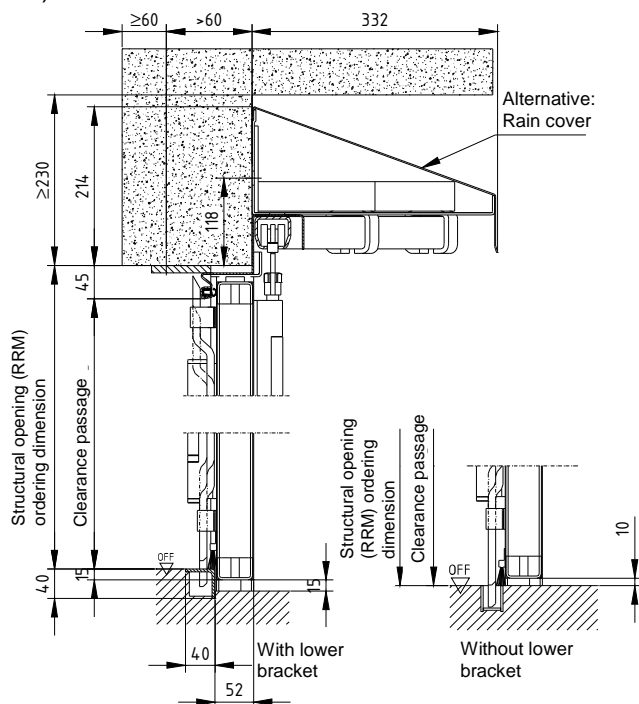

9.3 Corner installation, 180° opening, double rail

(outward opening shown)

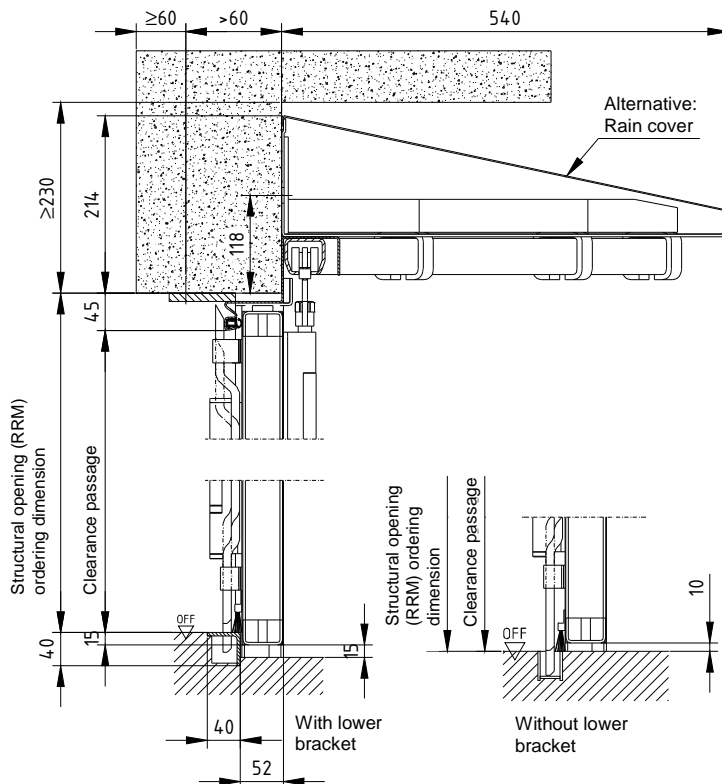

9.4 Installation in front of the soffit, 90° opening

(outward opening shown)

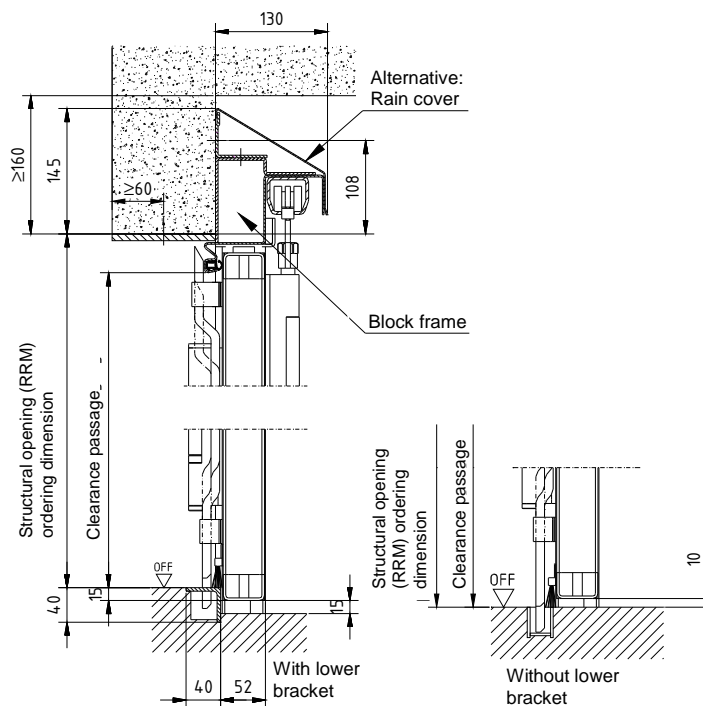

9.5 Installation in front of the soffit, 180° opening, single rail (outward opening shown)

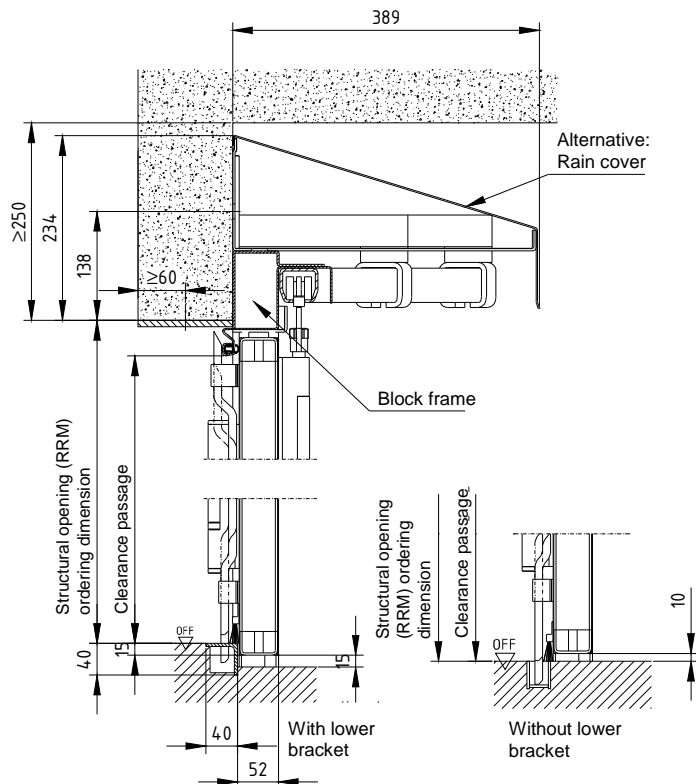

9.6 Installation in front of the soffit, 180° opening, double rail (outward opening shown)

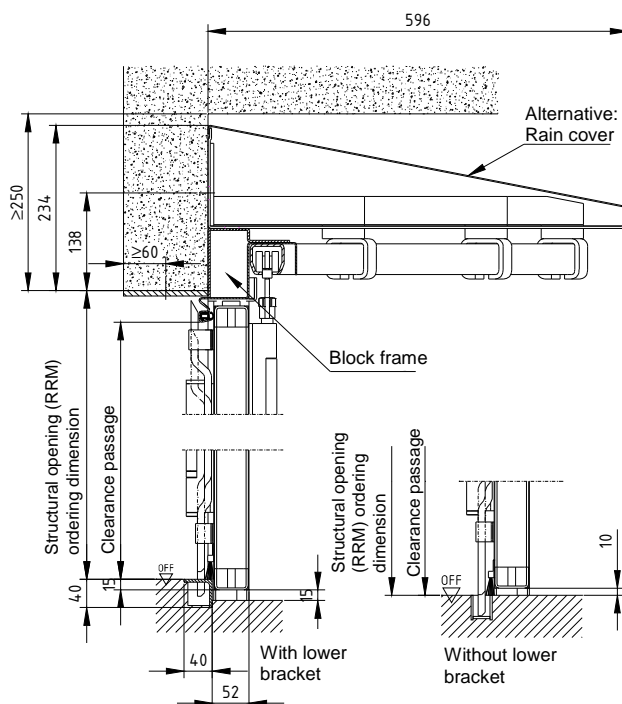

9.7 Installation in the soffit (outward opening shown)

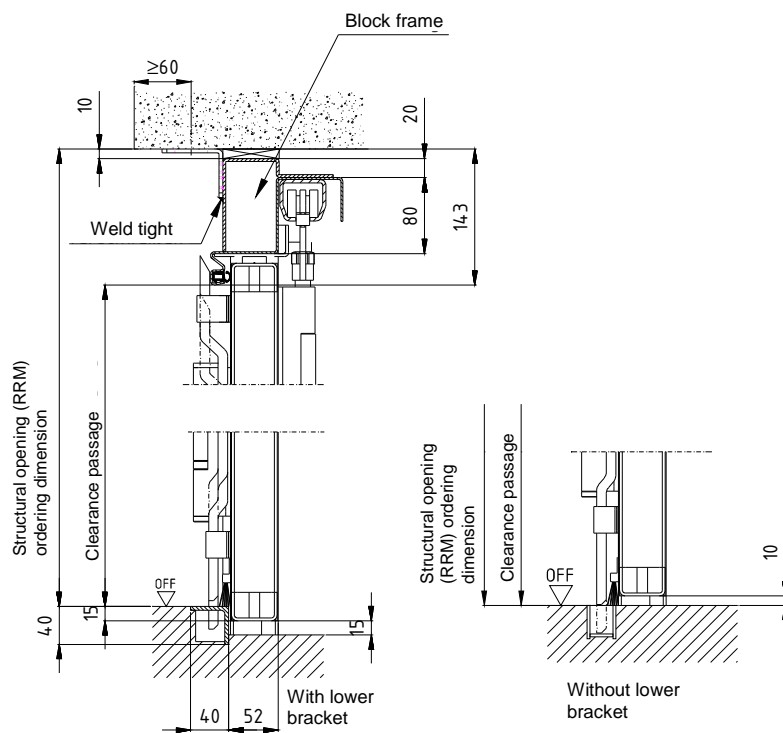

10. Bottom Door Leaf

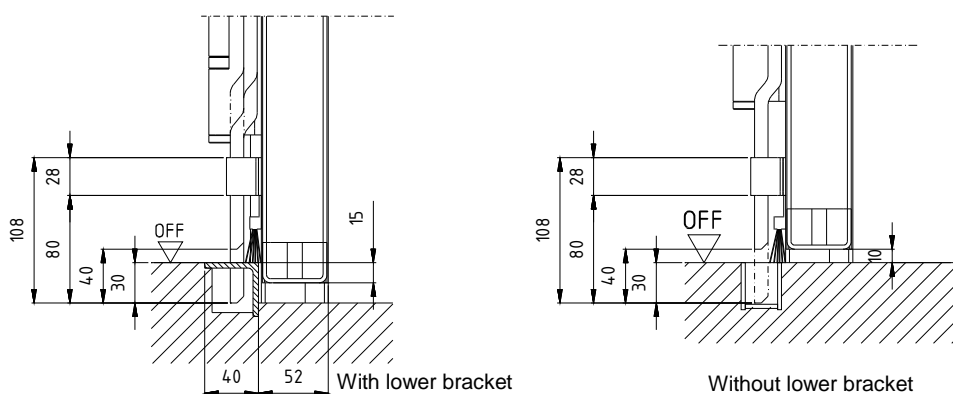

10.1 Floor recess installation

The floor anchors welded to the angular profile have to bent and cast with mortar in the prepared floor recesses.

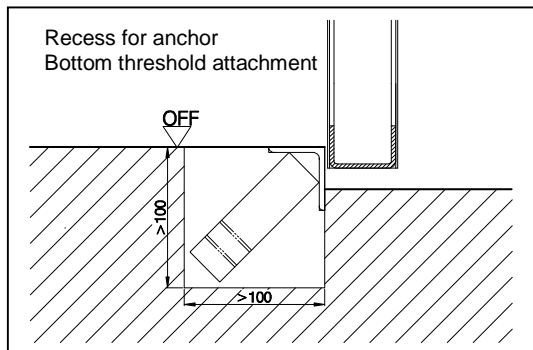

11. Drive and Protective Mechanisms / Fire Brigade Unlocking

Folding doors with 2:2, 0:2 or 2:0 connection can be equipped with an electric drive including a corresponding control and additional safety edge devices. Other types of connection and drive are only permissible after prior release by Teckentrup GmbH & Co. KG.

Fire brigade folding doors must have a 2:2 connection. Please see the separate installation and operating instructions for respective installation details and connection plans.

A door with drive must fulfil the requirements of DIN EN 12453.

The fire brigade folding door must fulfil the requirements of DIN 14092-2.

12. Leaf Hold-Open Devices

The leaves of the majority of the connection variants are equipped with leaf hold-open devices by the manufacturer. These hold open the individual leaf or the double leaves when the door is open. Check correct functioning after door assembly.

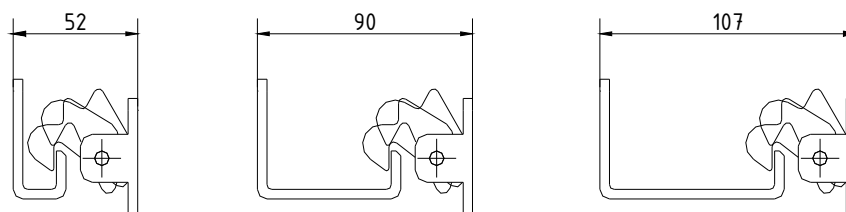

13. Door Hold-Open Devices

Doors which open 180° and 90° are equipped with a wall hold-open and a floor hold-open device respectively by the manufacturer. The door can be supplied with drop bolts on request. Adjustment/Installation occurs individually depending on the model.

Important:

Ensure that the folding door is not opened beyond 90° / 180°, otherwise the guide rail or the guide roller may be destroyed.

The door hold-open device must be fitted immediately after assembly.

14. Glazing Elements

Various glass and glazing variants are can be supplied.

The glazing elements are fixed in a rubber frame by the manufacturer. The glazing elements can - if not installed by the manufacturer - also be fixed in aluminium profiles by the customer.

- The manufacturer shall assume no liability for injuries or damage to persons or property caused by non shatter-proof glass or incorrect installation by third parties.
- The manufacturer only installs shatter-proof glass which complies with the requirements of DIN EN 12600.
- Please note that any glass which has to be replaced must have the same performance properties in accordance with DIN EN 12600 as regards impact resistance, etc. as the glazing elements installed by the manufacturer.
- Please contact Teckentrup GmbH & Co. KG for more information about permissible and manufacturer installed glazing elements.
- Glazing work should only be carried out by qualified personnel. The retrofitting of door leaves with transparent (glass) panels is strictly forbidden.



14.1 Aluminium clamping profile

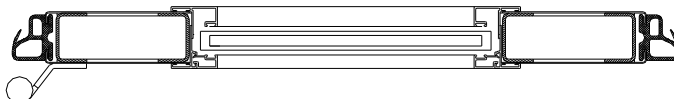

14.2 Rubber clamping profile

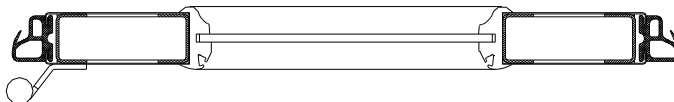

14.3 Steel glass strip

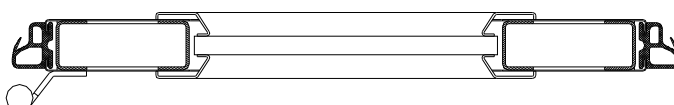

15. Wicket Doors

15.1 Wicket door without threshold and folding door with lower bracket

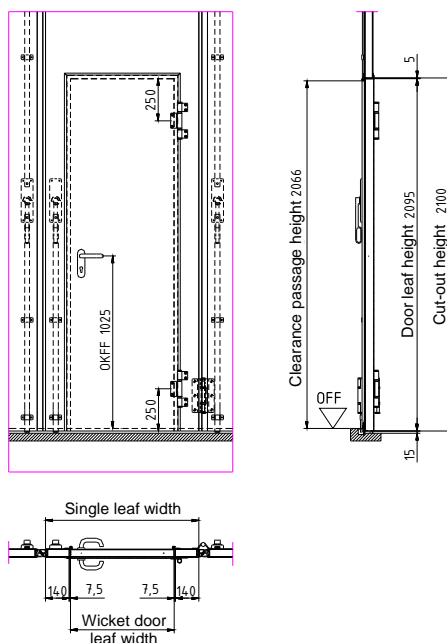

15.2 Wicket door without threshold and folding door without lower bracket

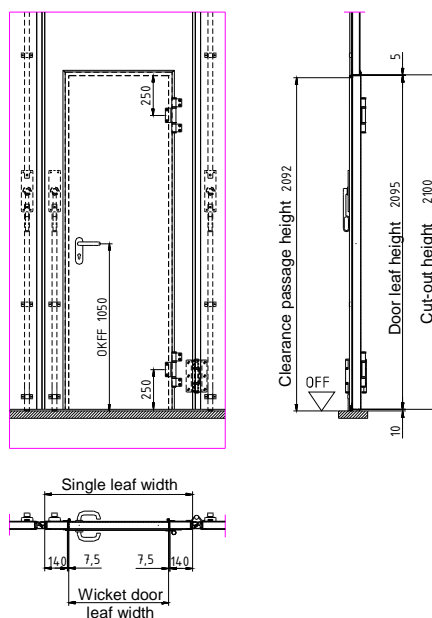

Caution!

Wicket doors without a threshold for escape routes and emergency exits must be equipped with tested fitting and lock combinations in accordance with EN 179 or EN 1125 and be in agreement with the local regulations for escape route and emergency exit doors.

15.3 Wicket door with threshold and folding door with lower bracket

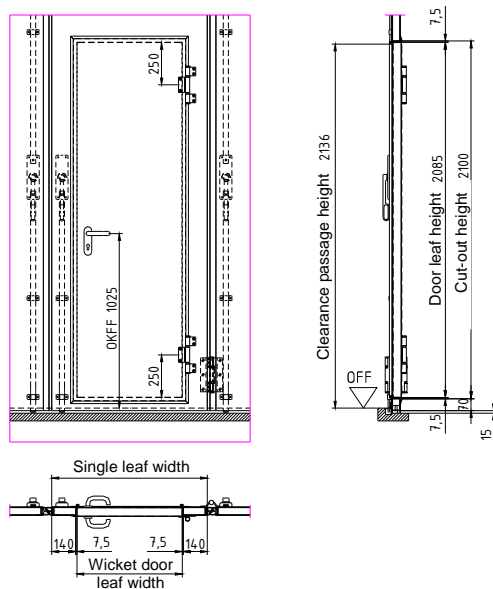

15.4 Wicket door with threshold and folding door without lower bracket

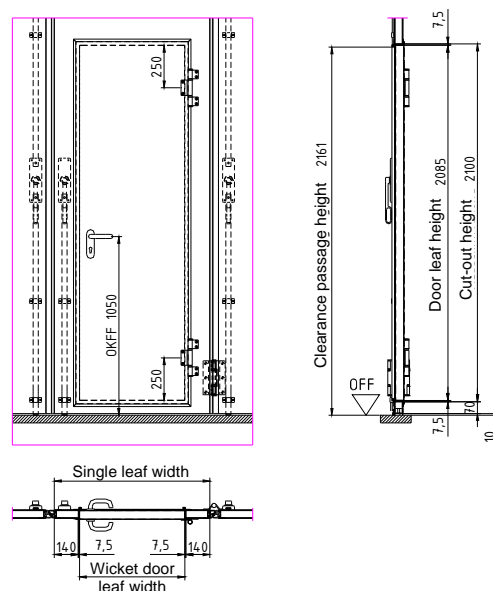

Caution!

Wicket doors for folding doors with a lower bracket (sill) are not generally permitted as access doors for escape routes and emergency exits.

16. Sectioned Access Door Panels

Sectioned access door panels are not possible for even connections (e.g. 2:2, 4:4, 2:4 etc.)!

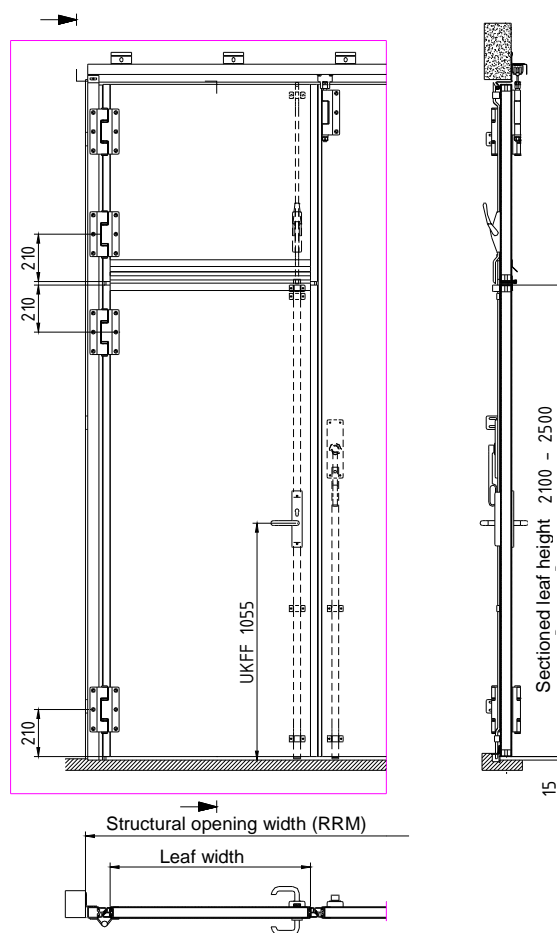

Caution!

Door access panels with a standard fitting are not permitted for escape routes and emergency exits!

17. General Safety Instructions for Assembly

Caution:

It has to be possible to unlock folding doors with external secure rod bolts from the inside or there has to be separate access to prevent people being accidentally locked inside the building.

- Always observe the maximum permissible loads when using lifting gear and devices. The weight of the door is approx. 28kg/m².
- Only use intact and certified lifting devices (assembly cranes, fork lifts) and lifting gear (cables, chains, belts).
- Before lifting the elements ensure that the load is secured correctly and that it can neither become loose nor slip. The elements can suddenly jerk and swing – beware risk of injuries!
- During assembly avoid wind loads on the not fully assembled door, e.g. in thoroughfares or subways. Close or secure all openings in advance.
- During the entire assembly period ensure that individual door elements and components cannot fall down or be knocked down.
- Always wear suitable protective clothing during assembly (protective gloves, hats, boots, etc).

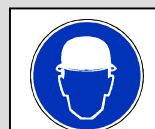

- Always use scaffolding or lifting platforms to carry out assembly work at >2 m.
- Ensure that any unauthorized persons cannot enter the installation area during assembly.
- Plan disassembly in accordance with local conditions. Disassembly is carried out in reverse order to assembly. Observe the specified assembly safety instructions.

