

Instructions
for fitters



CARTECK SECTIONAL DOOR (XL)

Use of a mounting rail

ADDITION TO THE ASSEMBLY INSTRUCTIONS

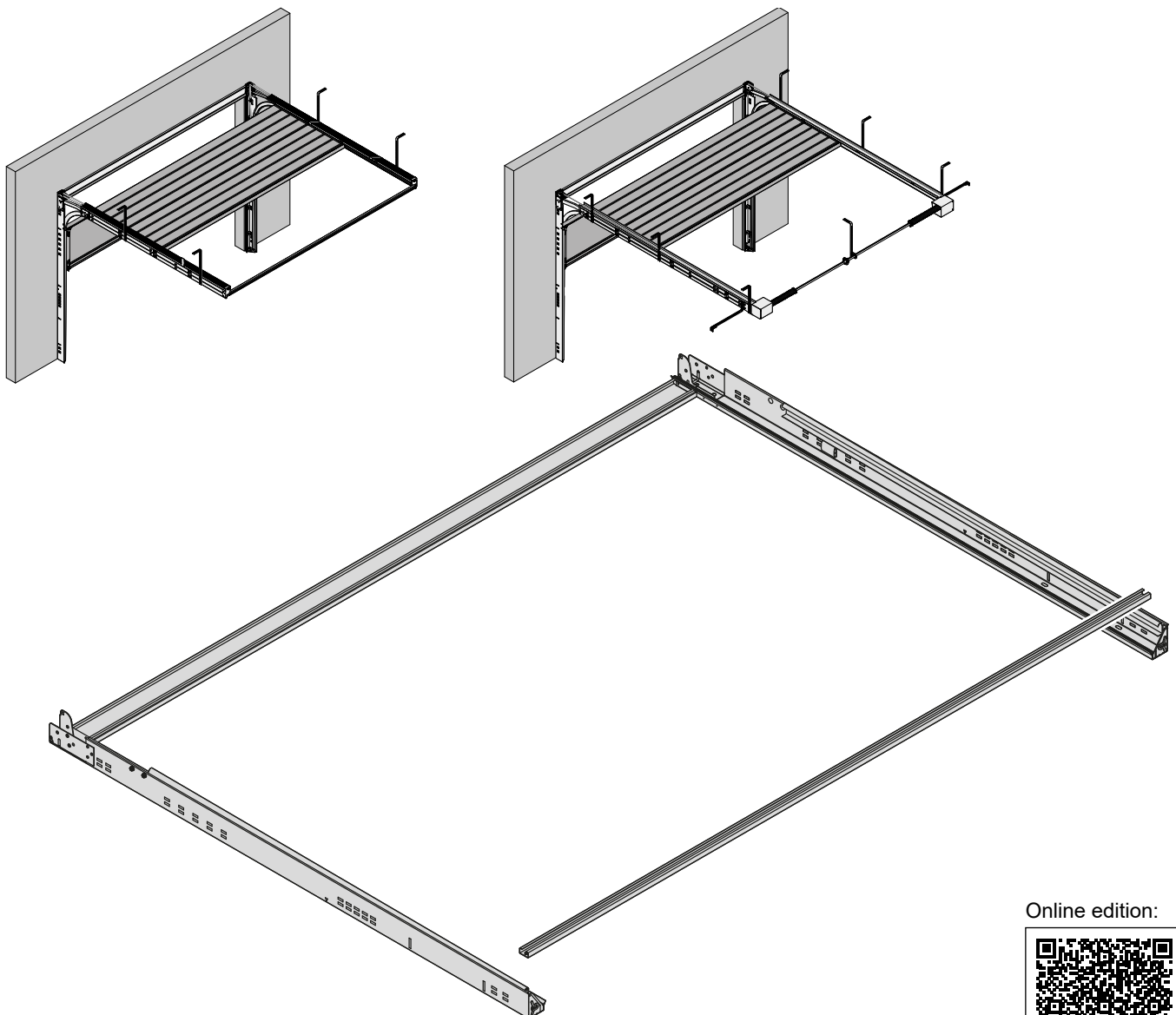

Online edition:



IMPORTANT!

Read carefully before use!
Keep for future reference!

Legal notice:

Title:	CarTeck sectional door (XL) Use of a mounting rail
Material number:	216603 Addendum to: 207727 - CarTeck sectional door 211135 - CarTeck sectional door XL
Language:	English (en)
Version:	09/2025
Issue / status:	08/09/2025
Issued by:	Teckentrup GmbH & Co. KG Industriestraße 50 33415 Verl www.teckentrup.biz
Copyright:	© Teckentrup GmbH & Co. KG Text and illustrations in this documentation are protected by copyright. Reproduction, even in part, only with the authorisation of Teckentrup GmbH & Co. KG.
Change notice:	Subject to technical changes

1. Document information

1.1. About these instructions

These instructions describe how to use an additional mounting rail to ensure that the door system is aligned at the correct angle during installation.

The assembly instructions supplement the following instructions:

- Garage sectional door:
Installation, operating and maintenance instructions
- CarTeck sectional door XL:
Installation, operating and maintenance instructions

1.2. Note on presentation

In order to ensure optimal identification for the use of components and parts, some of these have not been depicted to scale.

1.3. Target group

The instructions are intended for fitters and service technicians who are responsible for the installation, commissioning, testing, and maintenance of the door system.

This group of people is referred to below as "experts".

1.4. Qualification of the target group



Experts have technical training, e.g. as metalworkers, locksmiths, mechatronics engineers, electricians or a comparable qualification. As a specialist, you are responsible for the installation, commissioning, maintenance, repair, dismantling and disposal of the door system.















Experts shall meet the following requirements: ¹⁾

- Knowledge of occupational health and safety regulations and accident prevention
- Training in the use of appropriate protective equipment.
- Qualification and experience in handling live components of the system
- Knowledge of how to prevent personal injury or property damage when operating automated door systems.
- Qualification for testing, assessing and repairing mechanical components, e.g. springs, cables, guides and bearings.
- Qualification for the professional testing and adjustment of protective elements and safety devices, e.g. sensors, light barriers.
- Experience in implementing product-specific requirements and technical documentation, ensuring correct labelling and compliance with safety requirements.
- Experience in reading and implementing technical drawings and connection diagrams

¹⁾ Basis:
EN 12453 - Safety in use of power-operated doors - Requirements
EN 12604 - Doors – Mechanical aspects - Requirements and test procedures
EN 12978 - Safety devices for power-operated doors and gates / Requirements and test methods
EN 13241-1 - Doors - Product standard Part 1: Products without fire and smoke protection properties

1.5. Symbols used

Symbol	Meaning
	Action required
	Listing
	Dimensions in mm

Symbol	Meaning
	Warning of danger
	Information for fitters
	At least 2 persons required
	Follow the instructions
	Prerequisite before an action
	Correct
	Incorrect
	Conclusion of the action / result
	Perform on both sides of the door
	Additional information
	Important: please note
	Sequence of action steps
	Direction of movement
	Perform visual inspection

2. Safety

2.1. Explanation of warnings

WARNING

Notes with the signal word **WARNING** warn of a dangerous situation that can lead to death or serious injury if not avoided.

CAUTION

Notes with the signal word **CAUTION** warn of a situation that can lead to minor or moderate injuries if not avoided.

ATTENTION

Notes with the signal word **ATTENTION** warn of a situation that can lead to property damage or environmental damage if not avoided.

2.2. General safety instructions

- ▶ Keep these instructions in a safe place.

To ensure safe and long-lasting use of the product and to prevent damage, the following points must be observed:

- ▶ Read and follow these instructions.
- ▶ Please note the applicable documents.
- ▶ Use the installation materials in accordance with their intended purpose.
- ▶ Before commissioning, check that everything is working properly and that everything has been installed correctly.

Use is prohibited in the following cases:

- In the event of damage to the product or individual components.
- After improper installation.
- In the event of missing or non-functioning protective devices.

2.3. Instructions for safe installation

Observe the following instructions to prevent damage to property and personal injury:

- ▶ Secure the work area against access by unauthorised persons.
- ▶ For work that must be carried out by more than one person, ensure that an assistant is available.
- ▶ Use appropriate protective equipment to prevent injury.
- ▶ Use the fixing material from the installation package.
- ▶ Ensure that the correct fixing material is used to prevent damage.

2.4. Required protective equipment

- Work gloves
- Safety footwear

3. Set up the door frame with mounting rail

3.1. Requirements prior to installation

- ☑ Section 3.5. in the assembly instructions is complete.

3.2. Fit the rail between the frames

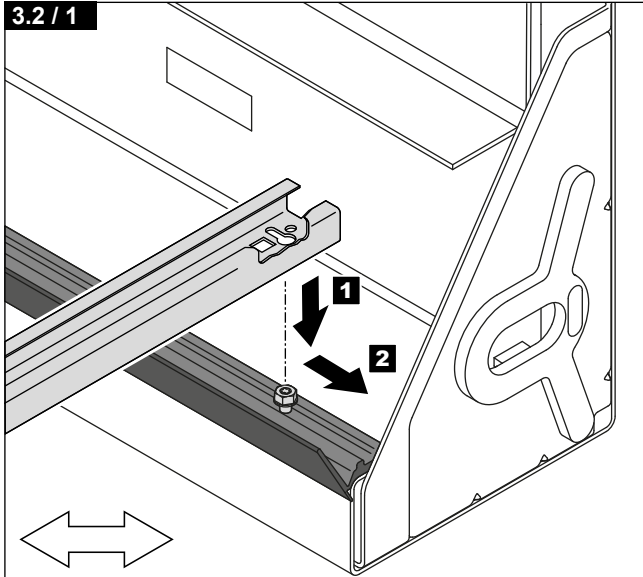

- ▶ Hang the C-rail on both sides into the pre-mounted sheet metal screws above the frame foot.

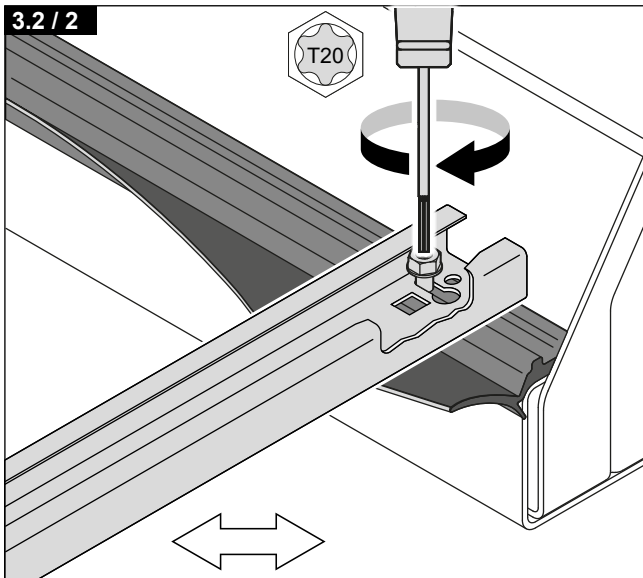

- ▶ Ensure that the screw is fully engaged in the hole in the C-rail.
- ▶ Tighten the screw securely.
- ▶ Repeat the process on the opposite frame.

3.3. Setting up the door frame

⚠ WARNING

Injuries caused by incorrect assembly.

Incorrectly installed door frames can tip over and cause serious injury or death.

- ▶ At least two persons must be present to erect the door frame.
- ▶ Ensure that the door frame sections are in the correct arrangement when setting them up and that they are aligned at right angles to each other.

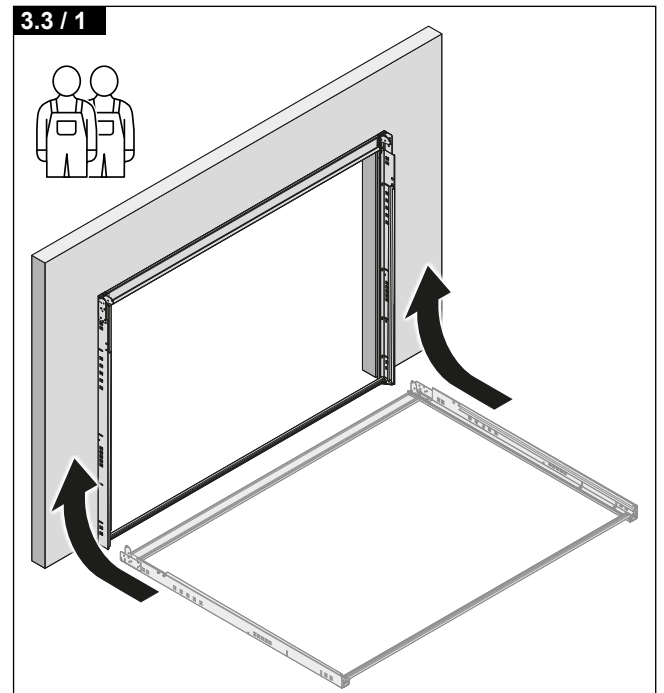

- ▶ Position the pre-assembled frame inside the passageway opening.

ATTENTION

Malfunctions and damage to property due to inaccurate alignment of the frame.

- ▶ When aligning the frame, ensure that the correct dimensions from the installation drawing are adhered to.
- ▶ After completing the installation, check the alignment and correct fastening.

3.4. Aligning and fixing the door frame

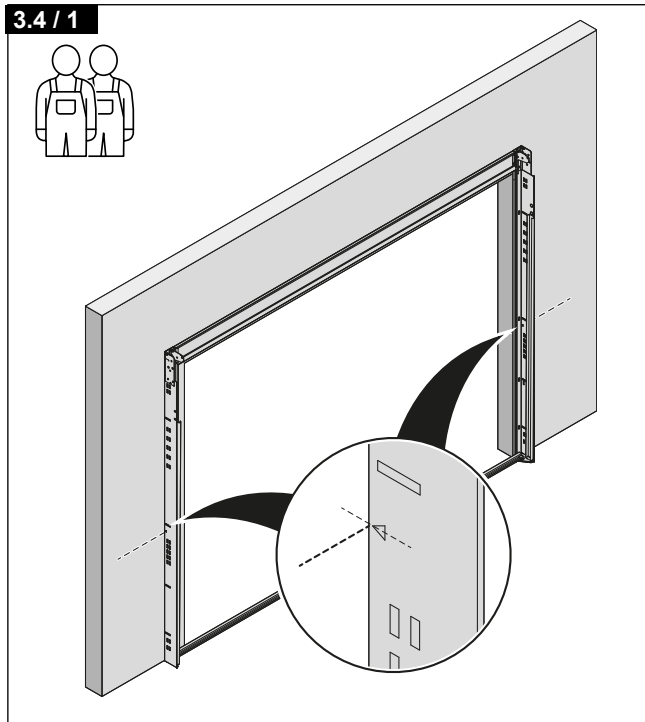

- ▶ Align the stamped mark on both sides of the door frame with the mark on the masonry.
- ▶ Align the door frame centrally with the door opening.

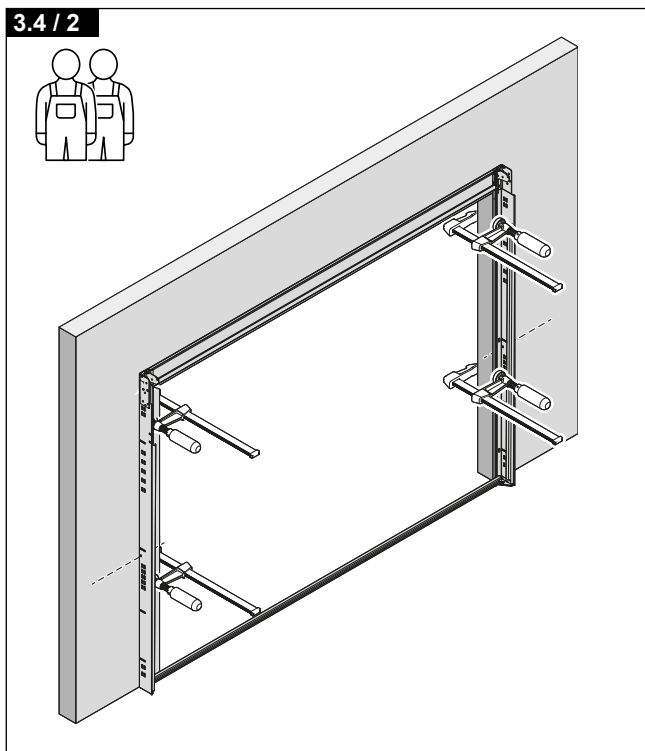

- ▶ Secure the position with screw clamps.

3.5. Checking the alignment of the door frame

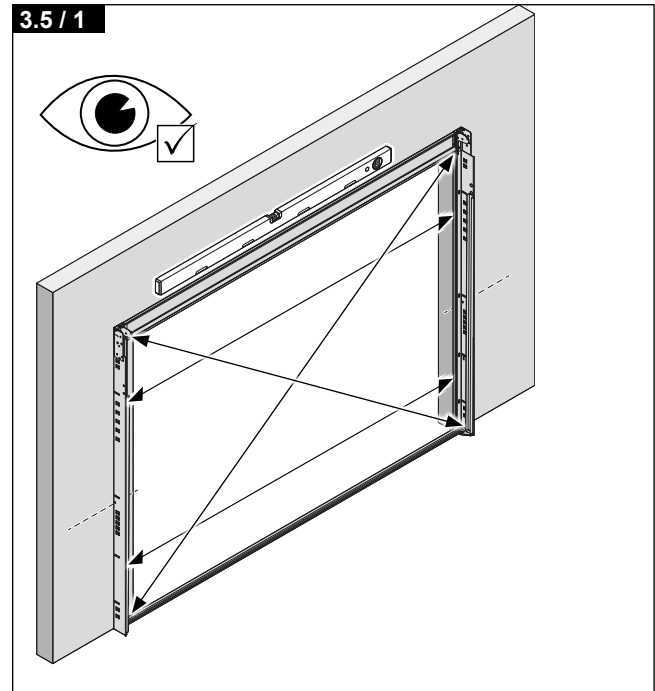

- ▶ Measure the distance between the door frames at the top and bottom. The distances must be the same at the top and bottom. Clear door frame size = order size width
- ▶ Check the diagonal measurements.
- ▶ Check that the door frame is fixed horizontally in the door opening.

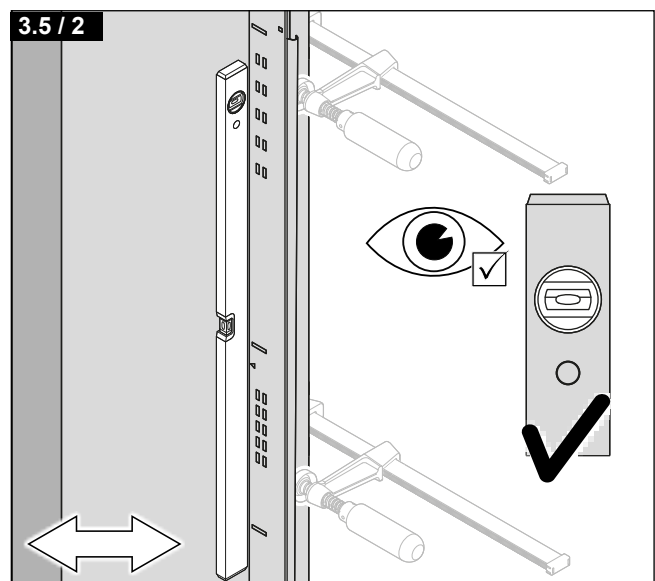

- ▶ Check that the right and left door frames are aligned perpendicular to the door opening.
- ▶ If necessary, correct the alignment of the door frame.

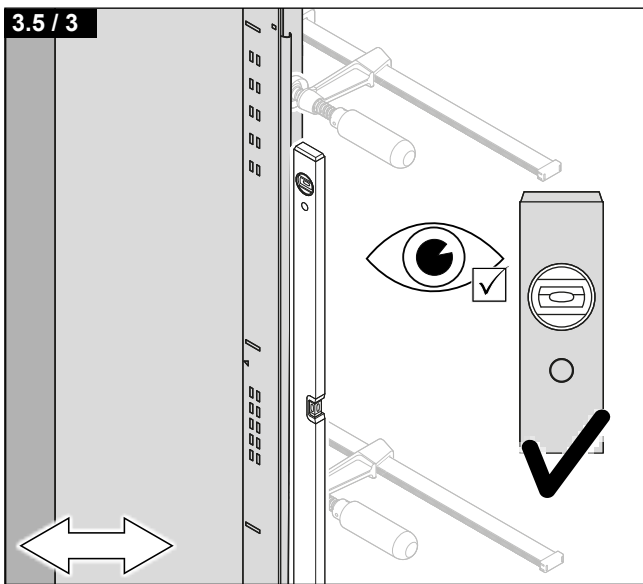

- ▶ Check that the right and left door frames are aligned perpendicular to the wall.
- ▶ If the door frame is not vertical, it must be shimmed.

3.6. Removing the mounting rail

Prerequisites:

- ☑ The alignment of the door frame was checked.
- ☑ The door frame is vertical.
- ☑ The door frames and lintel are connected at a right angle (90 °).

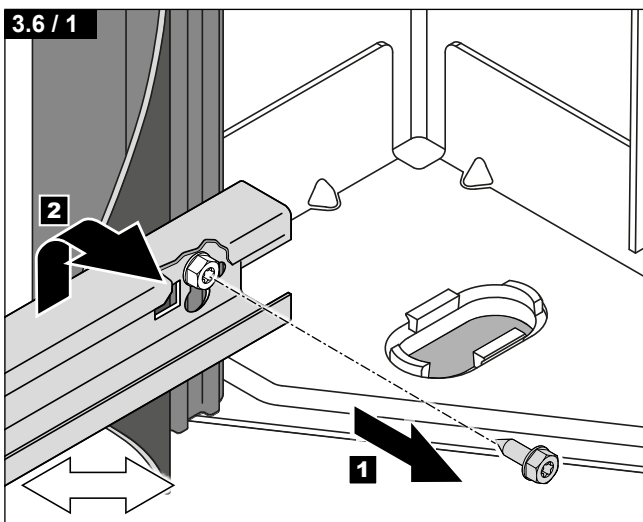

- ▶ Loosen the screw securing the C-profile on both sides.
- ▶ Remove the C-profile.
- ▶ Set the C-profile aside for later use.
- ▶ Remove the screw from the door frame seal.
- ▶ Dispose of the screw.

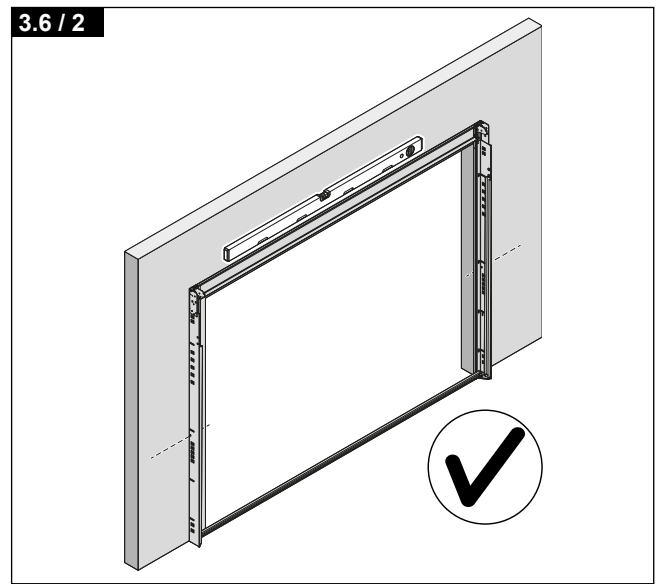

3.7. Continuing installing the gate system



Further assembly is described in the installation, operating and maintenance instructions.

- ▶ Go to the main instructions.
- ▶ Follow the installation instructions from chapter 3.8, "Screwing the frame together".

See also:

- ▶ [Installation instructions for garage sectional door](#)



- ▶ [Installation instructions for CarTeck sectional doors XL](#)



Do you still have questions? We are happy to help and advise you! Talk to your Teckentrup adviser.

How to reach us:

Teckentrup GmbH & Co. KG

Industriestraße 50 • 33415 Verl

T: +49 5246 504 - 0 • T: +49 5246 504 - 230

info@teckentrup.biz • www.teckentrup.biz
